



4L60-E

HYDRA-MATIC

CONTENTS

INTRODUCTION	3
HOW TO USE THIS BOOK	4
UNDERSTANDING THE GRAPHICS	6
TRANSMISSION CUTAWAY VIEW (FOLDOUT)	8
GENERAL DESCRIPTION	9
PRINCIPLES OF OPERATION	9A
MAJOR MECHANICAL COMPONENTS (FOLDOUT)	10
RANGE REFERENCE CHART	11
TORQUE CONVERTER	12
APPLY COMPONENTS	15
PLANETARY GEAR SETS	24
HYDRAULIC CONTROL COMPONENTS	26
ELECTRICAL COMPONENTS	36
POWER FLOW	45
COMPLETE HYDRAULIC CIRCUITS	73
LUBRICATION POINTS	98
BUSHING AND BEARING LOCATIONS	99
SEAL LOCATIONS	100
ILLUSTRATED PARTS LIST	101
BASIC SPECIFICATIONS	112
PRODUCT DESIGNATION SYSTEM	113
GLOSSARY	114
ABBREVIATIONS	116
INDEX	117

PREFACE

The Hydra-matic 4L60-E Technician's Guide is intended for automotive technicians that are familiar with the operation of an automatic transaxle or transmission. Technicians or other persons not having automatic transaxle or transmission know-how may find this publication somewhat technically complex if additional instruction is not provided. Since the intent of this book is to explain the fundamental mechanical, hydraulic and electrical operating principles, technical terms used herein are specific to the transmission industry. However, words commonly associated with the specific transaxle or transmission function have been defined in a Glossary rather than within the text of this book.

The Hydra-matic 4L60-E Technician's Guide is also intended to assist technicians during the service, diagnosis and repair of this transaxle. However, this book is not intended to be a substitute for other General Motors service publications that are normally used on the job. Since there is a wide range of repair procedures and technical specifications specific to certain vehicles and transmission models, the proper service publication must be referred to when servicing the Hydra-matic 4L60-E transmission.

© COPYRIGHT 2000 POWERTRAIN GROUP
General Motors Corporation

ALL RIGHTS RESERVED

All information contained in this book is based on the latest data available at the time of publication approval. The right is reserved to make product or publication changes, at any time, without notice.

No part of any GM Powertrain publication may be reproduced, stored in any retrieval system or transmitted in any form or by any means, including but not limited to electronic, mechanical, photocopying, recording or otherwise, without the prior written permission of Powertrain Group of General Motors Corporation. This includes all text, illustrations, tables and charts.

INTRODUCTION

The Hydra-matic 4L60-E Technician's Guide is another Powertrain publication from the Technician's Guide series of books. The purpose of this publication, as is the case with other Technician's Guides, is to provide complete information on the theoretical operating characteristics of this transmission. Operational theories of the mechanical, hydraulic and electrical components are presented in a sequential and functional order to better explain their operation as part of the system.

In the first section of this book entitled "Principles of Operation", exacting explanations of the major components and their functions are presented. In every situation possible, text describes component operation during the apply and release cycle as well as situations where it has no effect at all. The descriptive text is then supported by numerous graphic illustrations to further emphasize the operational theories presented.

The second major section entitled "Power Flow", blends the information presented in the "Principles of Operation" section into the complete transmission assembly. The transfer of torque from the engine through the transmission is graphically displayed on a full page while a narrative description is provided on a facing half page. The opposite side of the half page contains the narrative description of the

hydraulic fluid as it applies components or shifts valves in the system. Facing this partial page is a hydraulic schematic that shows the position of valves, ball check valves, etc., as they function in a specific gear range.

The third major section of this book displays the "Complete Hydraulic Circuit" for specific gear ranges. Foldout pages containing fluid flow schematics and two dimensional illustrations of major components graphically display hydraulic circuits. This information is extremely useful when tracing fluid circuits for learning or diagnosis purposes.

The "Appendix" section of this book provides additional transmission information regarding lubrication circuits, seal locations, illustrated parts lists and more. Although this information is available in current model year Service Manuals, its inclusion provides for a quick reference guide that is useful to the technician.

Production of the Hydra-matic 4L60-E Technician's Guide was made possible through the combined efforts of many staff areas within the General Motors Powertrain Group. As a result, the Hydra-matic 4L60-E Technician's Guide was written to provide the user with the most current, concise and usable information available regarding this product.



HOW TO USE THIS BOOK

First time users of this book may find the page layout a little unusual or perhaps confusing. However, with a minimal amount of exposure to this format its usefulness becomes more obvious. If you are unfamiliar with this publication, the following guidelines are helpful in understanding the functional intent for the various page layouts:

- Read the following section, “Understanding the Graphics” to know how the graphic illustrations are used, particularly as they relate to the mechanical power flow and hydraulic controls (see Understanding the Graphics page 6).
- Unfold the cutaway illustration of the Hydramatic 4L60-E (page 8) and refer to it as you progress through each major section. This cutaway provides a quick reference of component location inside the transmission assembly and their relationship to other components.
- The Principles of Operation section (beginning on page 9A) presents information regarding the major apply components and hydraulic control components used in this transmission. This section describes “how” specific components work and interfaces with the sections that follow.
- The Power Flow section (beginning on page 45) presents the mechanical and hydraulic functions corresponding to specific gear ranges. This section builds on the information presented in the Principles of Operation section by showing

specific fluid circuits that enable the mechanical components to operate. The mechanical power flow is graphically displayed on a full size page and is followed by a half page of descriptive text. The opposite side of the half page contains the narrative description of the hydraulic fluid as it applies components or moves valves in the system. Facing this partial page is a hydraulic schematic which shows the position of valves, ball check valves, etc., as they function in a specific gear range. Also, located at the bottom of each half page is a reference to the Complete Hydraulic Circuit section that follows.

- The Complete Hydraulic Circuits section (beginning on page 73) details the entire hydraulic system. This is accomplished by using a foldout circuit schematic with a facing page two dimensional foldout drawing of each component. The circuit schematics and component drawings display only the fluid passages for that specific operating range.
- Finally, the Appendix section contains a schematic of the lubrication flow through the transmission, disassembled view parts lists and transmission specifications. This information has been included to provide the user with convenient reference information published in the appropriate vehicle Service Manuals. Since component parts lists and specifications may change over time, this information should be verified with Service Manual information.

HOW TO USE THIS BOOK

LARGE CUTAWAY VIEW OF TRANSMISSION (FOLDOUT)

HALF PAGE TEXT FOR EASY REFERENCE TO BOTH PAGES

RANGE REFERENCE CHART

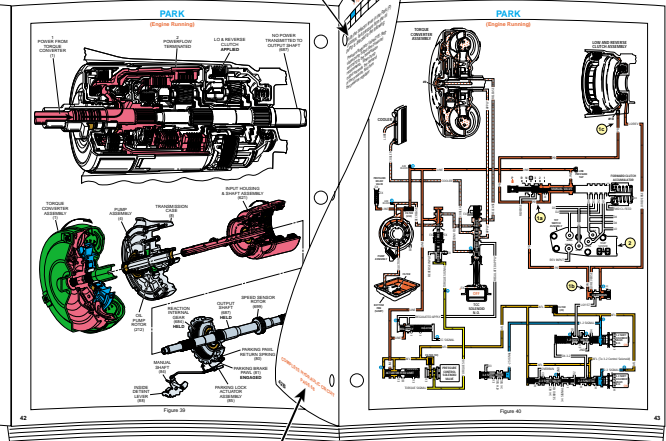
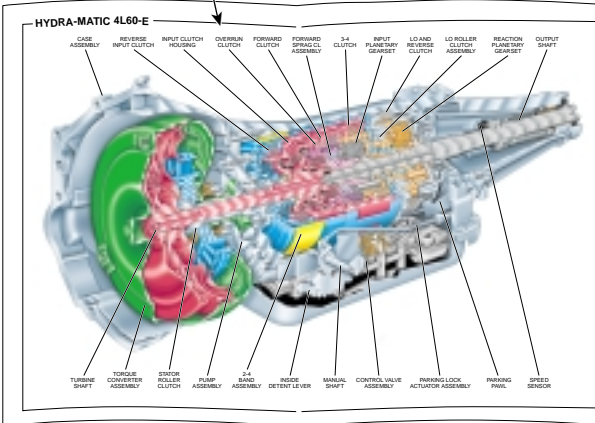

PAGE NUMBER — FOR REFERENCE TO FLUID FLOW SCHEMATIC

FLUID FLOW SCHEMATIC — (FOLDOUT)

FLUID FLOW THROUGH COMPONENTS (FOLDOUT)

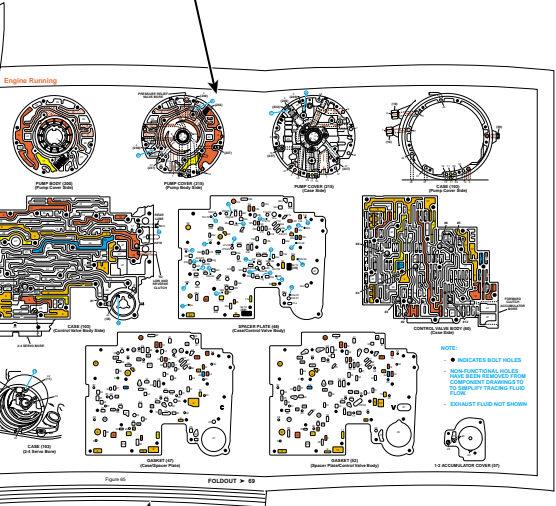
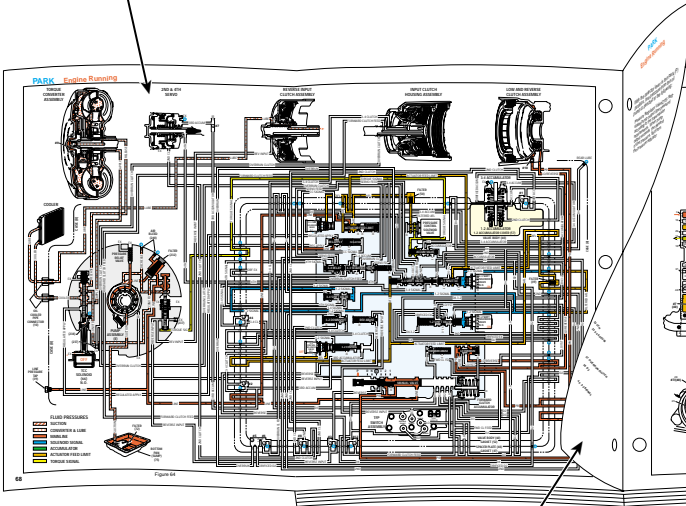

HALF PAGE TEXT AND LEDGEND

COMPLETE ILLUSTRATED PARTS LIST

Figure 1

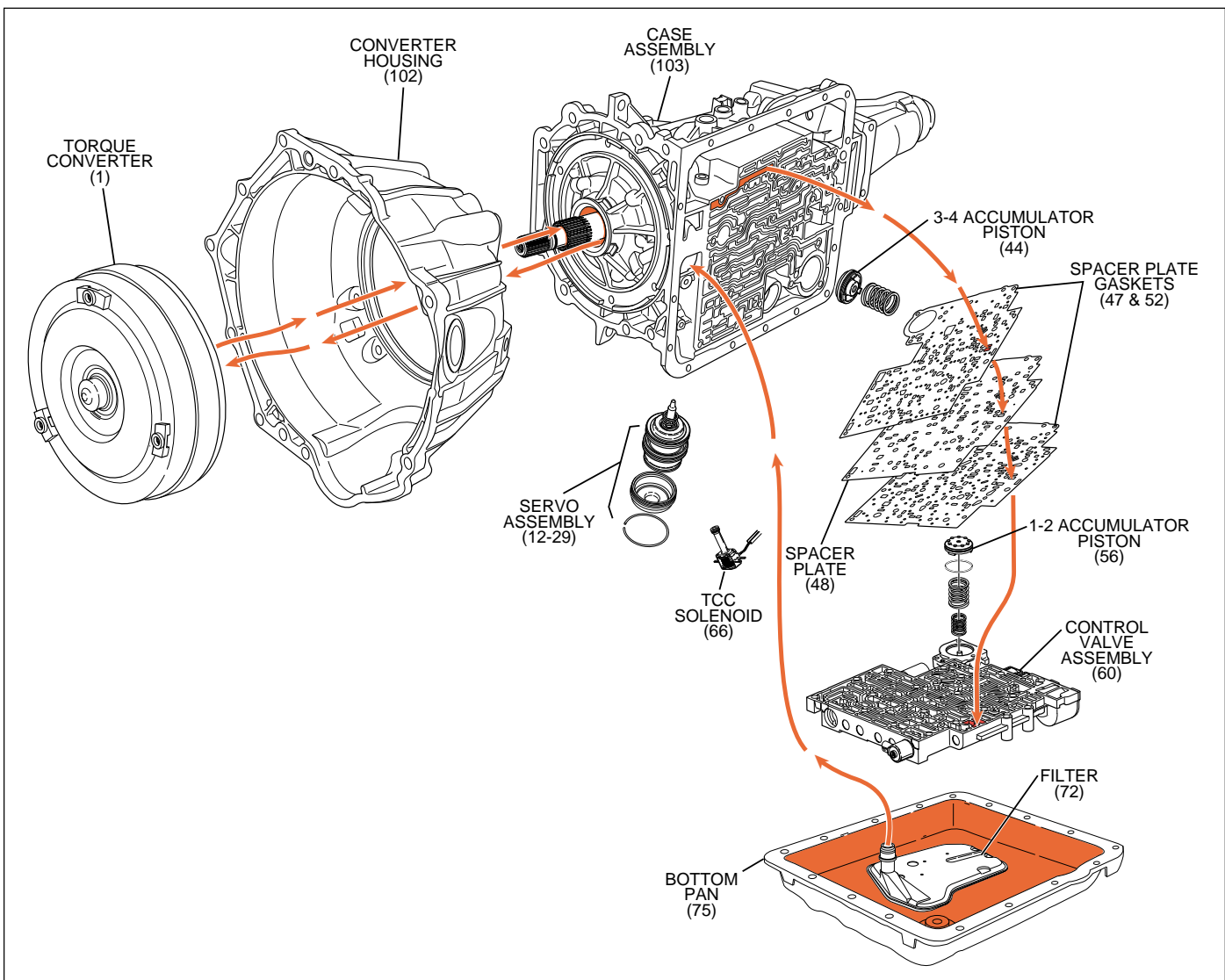

Figure 2

The flow of transmission fluid starts in the bottom pan and is drawn through the filter, main case valve body, transmission case, the oil pump assembly, and into the torque converter. This is a general route for fluid to flow that is more easily understood by reviewing the illustrations provided in Figure 2. However, fluid may pass between these and other components many times before reaching a valve or applying a clutch. For this reason, the graphics are designed to show the exact location where fluid passes through a component and into other passages for specific gear range operation.

To provide a better understanding of fluid flow in the Hydra-matic 4L60-E transmission, the components involved with hydraulic control and fluid flow are illustrated in three major formats. Figure 3 provides an example of these formats which are:

- A three dimensional line drawing of the component for easier part identification.
- A two dimensional line drawing of the component to indicate fluid passages and orifices.

- A graphic schematic representation that displays valves, checkballs, orifices and so forth, required for the proper function of transmission in a specific gear range. In the schematic drawings, fluid circuits are represented by straight lines and orifices are represented by indentations in a circuit. All circuits are labeled and color coded to provide reference points between the schematic drawing and the two dimensional line drawing of the components.
- Figure 4 (page 7B) provides an illustration of a typical valve, bushing and valve train components. A brief description of valve operation is also provided to support the illustration.
- Figure 5 (page 7B) provides a color coded chart that references different fluid pressures used to operate the hydraulic control systems. A brief description of how fluid pressures affect valve operation is also provided.

UNDERSTANDING THE GRAPHICS

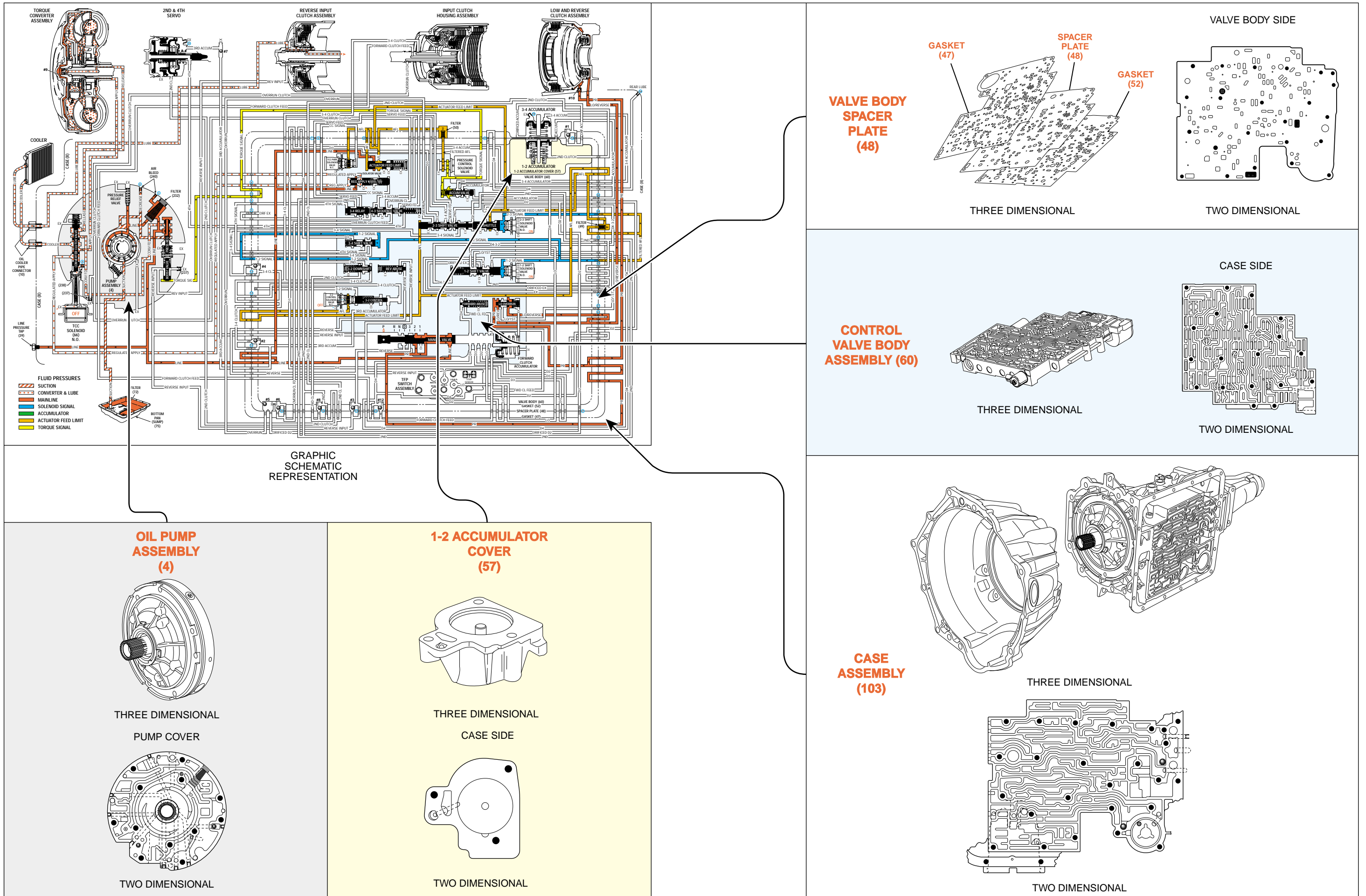
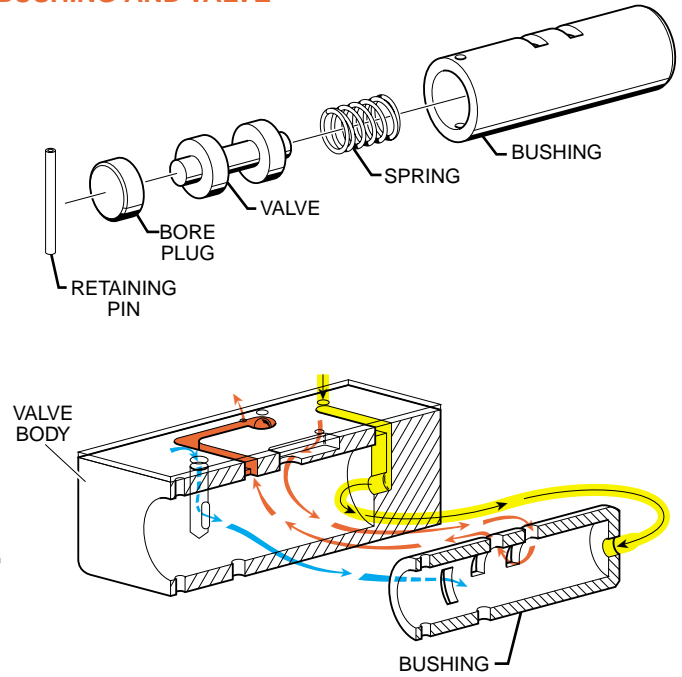
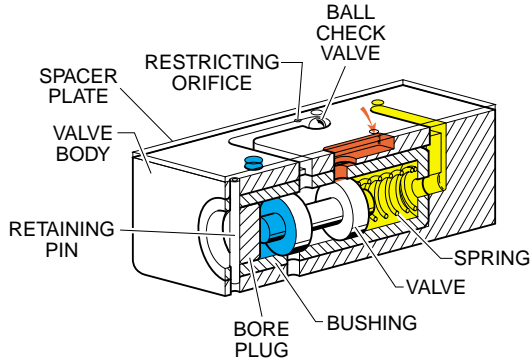

Figure 3

UNDERSTANDING THE GRAPHICS

TYPICAL BUSHING AND VALVE

NOTE: NOT ALL VALVES ARE USED WITH A BUSHING



EXHAUST FROM THE APPLY COMPONENT UNSEATS THE BALL CHECK VALVE, THEREFORE CREATING A QUICK RELEASE.

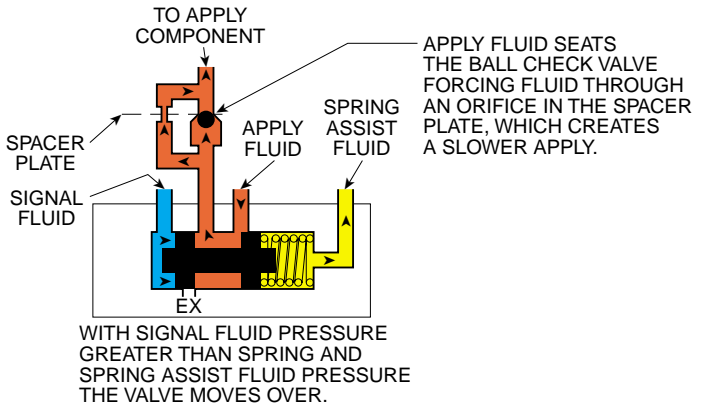
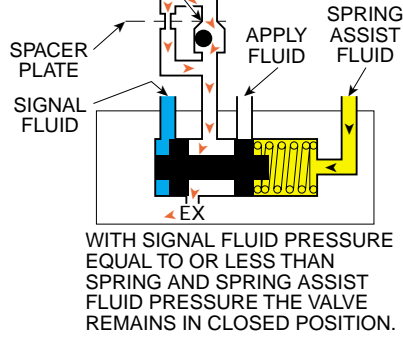









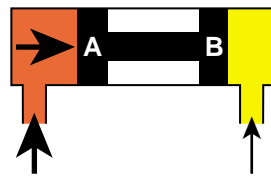

Figure 4

FLUID PRESSURES

-  SUCTION
-  CONVERTER & LUBE
-  MAINLINE
-  SOLENOID SIGNAL
-  ACCUMULATOR
-  ACTUATOR FEED LIMIT
-  TORQUE SIGNAL
-  EXHAUST
-  DIRECTION OF FLOW



WITH EQUAL SURFACE AREAS ON EACH END OF THE VALVE, BUT FLUID PRESSURE "A" BEING GREATER THAN FLUID PRESSURE "B", THE VALVE WILL MOVE TO THE RIGHT.

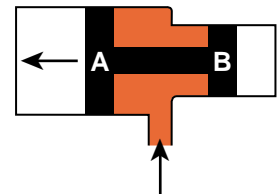

WITH THE SAME FLUID PRESSURE ACTING ON BOTH SURFACE "A" AND SURFACE "B" THE VALVE WILL MOVE TO THE LEFT. THIS IS DUE TO THE LARGER SURFACE AREA OF "A" THAN "B".

Figure 5

HYDRA-MATIC 4L60-E

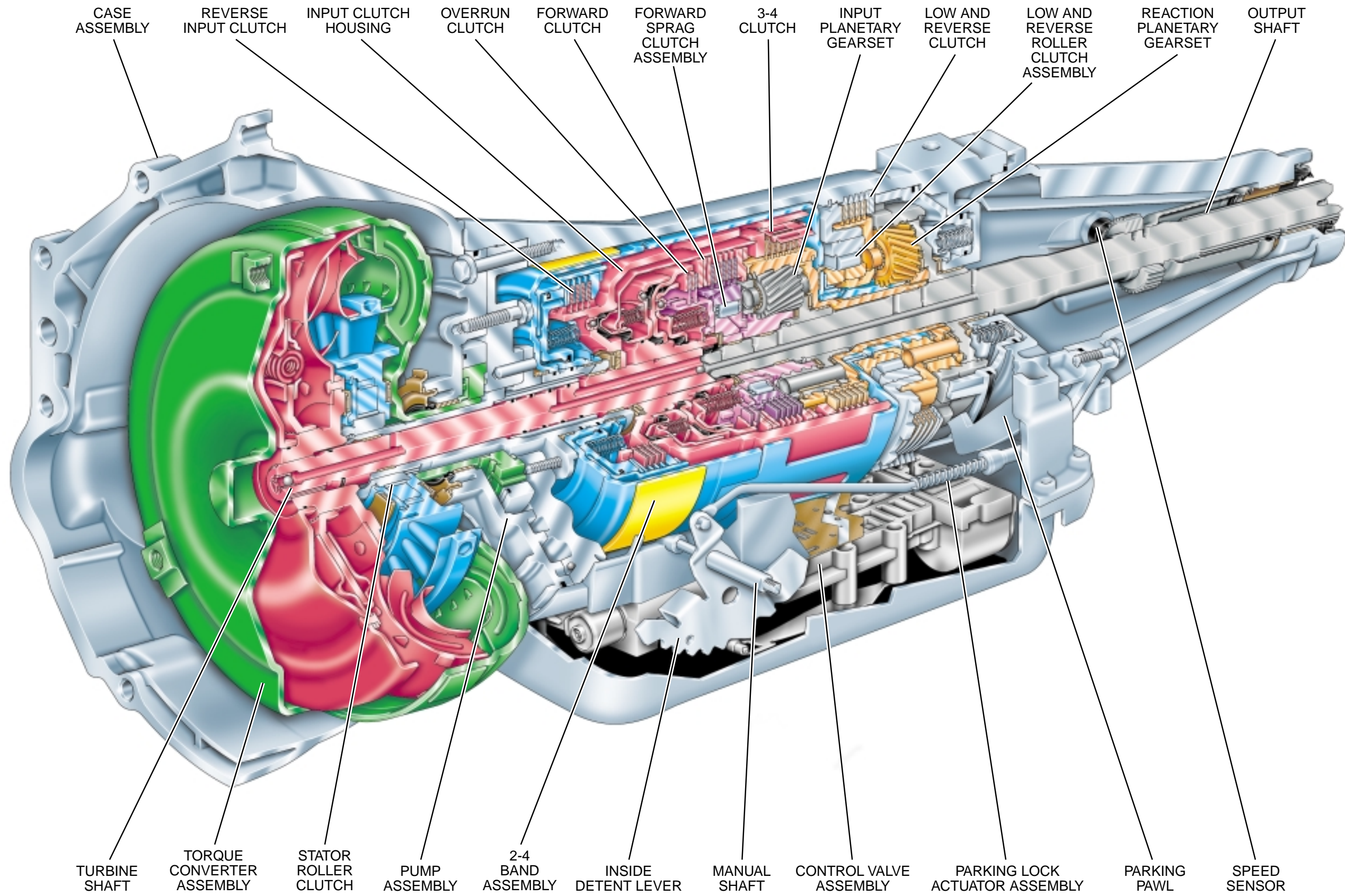

Figure 6

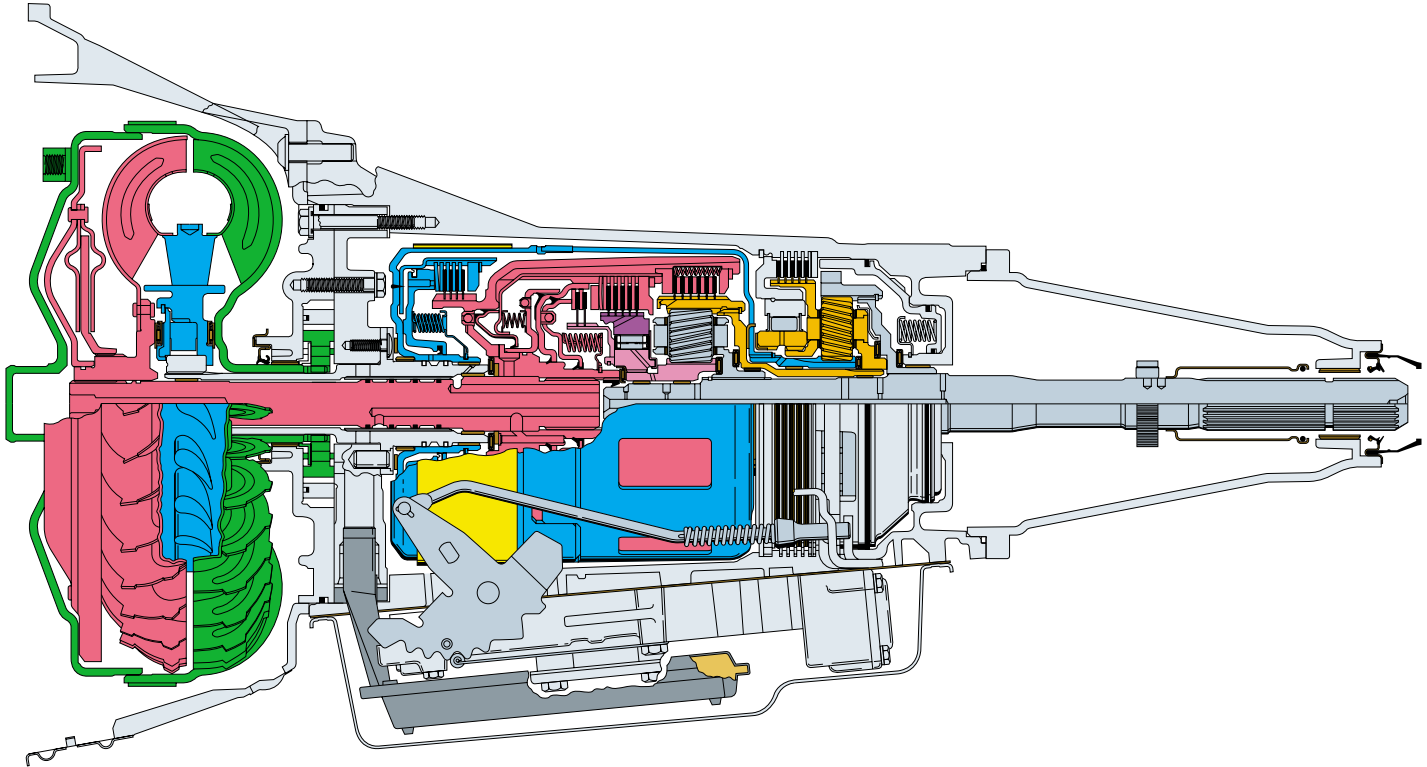

Figure 7

HYDRA-MATIC 4L60-E CROSS SECTIONAL DRAWING

A cross sectional line drawing is typically the standard method for illustrating either an individual mechanical component or a complete transmission assembly. However, unless a person is familiar with all the individual components of the transmission, distinguishing components may be difficult in this type of drawing. For this reason, a three dimensional perspective illustration (shown on page 8) is the primary drawing used throughout this book.

The purpose for this type of illustration is to provide a more exacting graphic representation of each component and to show their relationship to other components within the transmission assembly. It is also useful for

understanding the cross sectional line drawing by comparing the same components from the three dimensional perspective illustration. In this regard it becomes an excellent teaching instrument.

Additionally, all the illustrations contained in this book use a color scheme that is consistent throughout this book. In other words, regardless of the type of illustration or drawing, all components have an assigned color and that color is used whenever that component is illustrated. This consistency not only helps to provide for easy component identification but it also enhances the graphic and color continuity between sections.

GENERAL DESCRIPTION

The Hydra-matic 4L60-E is a fully automatic, four speed, rear wheel drive, electronically controlled transmission. It consists primarily of a four-element torque converter, two planetary gear sets, friction and mechanical clutches and a hydraulic pressurization and control system.

The four-element torque converter contains a pump, a turbine, a pressure plate splined to the turbine, and a stator assembly. The torque converter acts as a fluid coupling to smoothly transmit power from the engine to the transmission. It also hydraulically provides additional torque multiplication when required. The pressure plate, when applied, provides a mechanical "direct drive" coupling of the engine to the transmission.

The two planetary gear sets provide the four forward gear ratios and reverse. Changing gear ratios is fully automatic and is accomplished through the use of a Powertrain Control Module (PCM). The PCM receives and monitors various electronic sensor inputs and uses this information to shift the transmission at the optimum time.

The PCM commands shift solenoids, within the transmission, on and off to control shift timing. The PCM also controls the apply and release of the torque converter clutch which allows the engine to deliver the maximum fuel efficiency without sacrificing vehicle performance.

The hydraulic system primarily consists of a vane type pump, control valve body and case. The pump maintains the working pressures needed to stroke the servo and clutch pistons that apply or release the friction components. These friction components (when applied or released) support the automatic shifting qualities of the transmission.

The friction components used in this transmission consist of five multiple disc clutches and one band. The multiple disc clutches combine with two mechanical components, one roller clutch and one sprag clutch, to deliver five different gear ratios through the gear sets. The gear sets then transfer torque through the output shaft.

PRINCIPLES OF OPERATION

An automatic transmission is the mechanical component of a vehicle that transfers power (torque) from the engine to the wheels. It accomplishes this task by providing a number of forward gear ratios that automatically change as the speed of the vehicle increases. The reason for changing forward gear ratios is to provide the performance and economy expected from vehicles manufactured today. On the performance end, a gear ratio that develops a lot of torque (through torque multiplication) is required in order to initially start a vehicle moving. Once the vehicle is in motion, less torque is required in order to maintain the vehicle at a certain speed. When the vehicle has reached a desired speed, economy becomes the important factor and the transmission will shift into overdrive. At this point output speed is greater than input speed, and, input torque is greater than output torque.

Another important function of the automatic transmission is to allow the engine to be started

and run without transferring torque to the wheels. This situation occurs whenever Park (P) or Neutral (N) range has been selected. Also, operating the vehicle in a rearward direction is possible whenever Reverse (R) range has been selected (accomplished by the gear sets).

The variety of gear ranges in an automatic transmission are made possible through the interaction of numerous mechanically, hydraulically and electronically controlled components inside the transmission. At the appropriate time and sequence, these components are either applied or released and operate the gear sets at a gear ratio consistent with the driver's needs. The following pages describe the theoretical operation of the mechanical, hydraulic and electrical components found in the Hydra-matic 4L60-E transmission. When an understanding of these operating principles has been attained, diagnosis of these transmission systems is made easier.

EXPLANATION OF GEAR RANGES

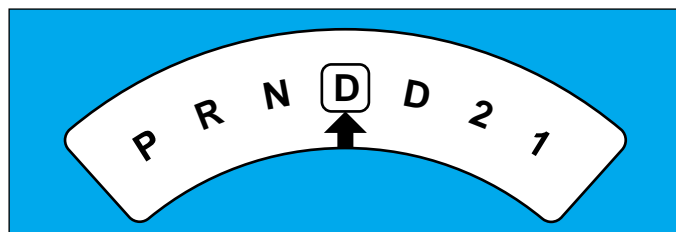

Figure 8

The transmission can be operated in any one of the seven different positions shown on the shift quadrant (Figure 8).

P – Park position enables the engine to be started while preventing the vehicle from rolling either forward or backward. For safety reasons, the vehicle's parking brake should be used in addition to the transmission "Park" position. Since the output shaft is mechanically locked to the case through the parking pawl and reaction internal gear, Park position should not be selected until the vehicle has come to a complete stop.

R – Reverse enables the vehicle to be operated in a rearward direction.

N – Neutral position enables the engine to start and operate without driving the vehicle. If necessary, this position should be selected to restart the engine while the vehicle is moving.

D – Overdrive range should be used for all normal driving conditions for maximum efficiency and fuel economy. Overdrive range allows the transmission to operate in each of the four forward gear ratios. Downshifts to a lower gear, or higher gear ratio are available

for safe passing by depressing the accelerator or by manually selecting a lower gear with the shift selector.

The transmission should not be operated in Overdrive towing a trailer or driving on hilly terrain. Under such conditions that put an extra load on the engine, the transmission should be driven in a lower manual gear selection for maximum efficiency.

D – Manual Third can be used for conditions where it may be desirable to use only three gear ratios. These conditions include towing a trailer and driving on hilly terrain as described above. This range is also helpful for engine braking when descending slight grades. Upshifts and downshifts are the same as in Overdrive range for first, second and third gears except that the transmission will not shift into fourth gear.

2 – Manual Second adds more performance for congested traffic and hilly terrain. It has the same starting ratio (first gear) as Manual Third but prevents the transmission from shifting above second gear. Thus, Manual Second can be used to retain second gear for acceleration and engine braking as desired. Manual Second can be selected at any vehicle speed but will not downshift into second gear until the vehicle speed drops below approximately 100 km/h (62 mph).

1 – Manual First can be selected at any vehicle speed. If the transmission is in third or fourth gear it will immediately shift into second gear. When the vehicle speed slows to below approximately 48 to 56 km/h (30 to 35 mph) the transmission will then shift into first gear. This is particularly beneficial for maintaining maximum engine braking when descending steep grades.

MAJOR MECHANICAL COMPONENTS

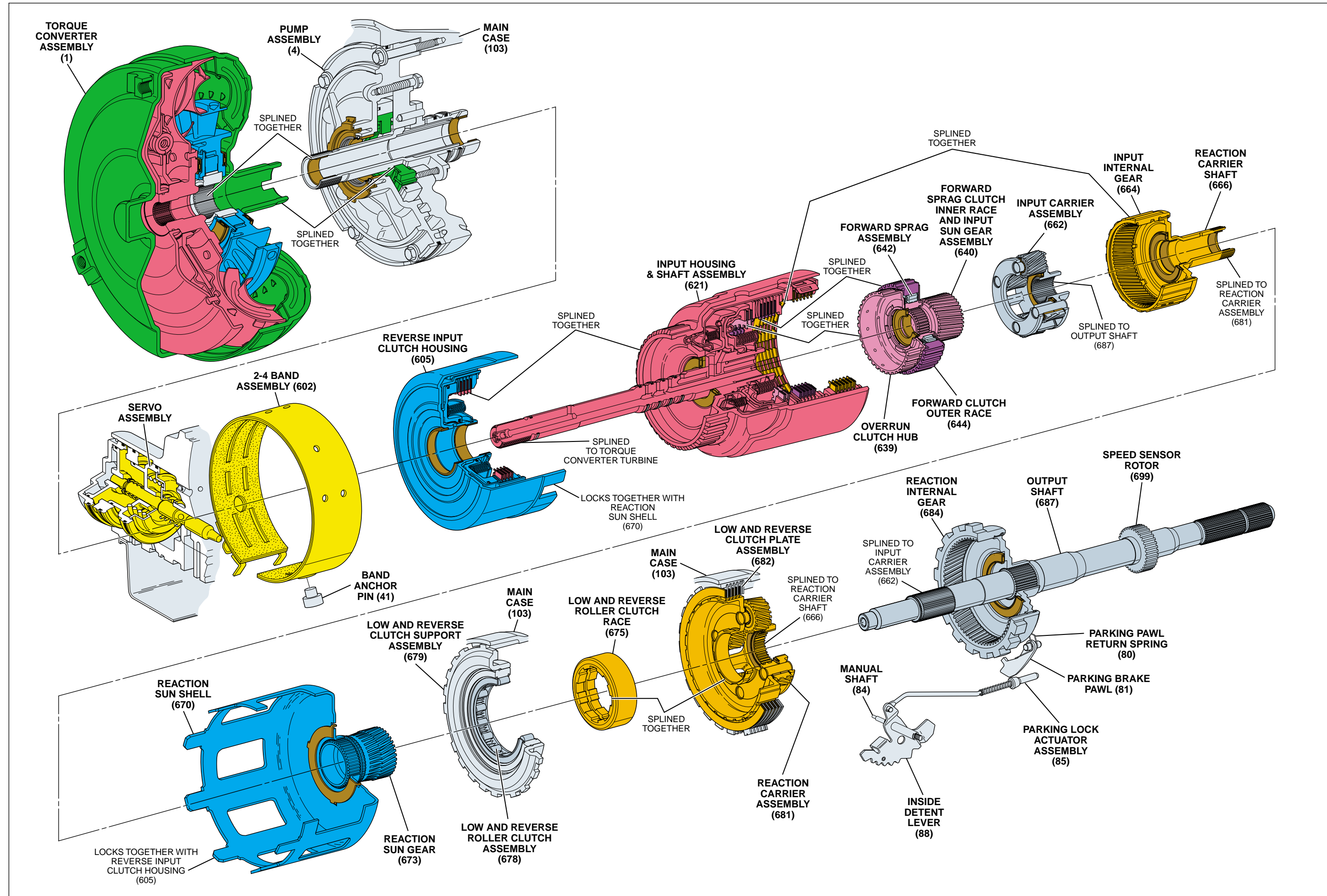











Figure 9

COLOR LEGEND

MAJOR MECHANICAL COMPONENTS

The foldout graphic on page 10 contains a disassembled drawing of the major components used in the Hydra-matic 4L60-E transmission. This drawing, along with the cross sectional illustrations on page 8 and 8A, show the major mechanical components and their relationship to each other as a complete assembly. Therefore, color has been used throughout this book to help identify parts that are splined together, rotating at engine speed, held stationary, and so forth. Color differentiation is particularly helpful when using the Power Flow section for understanding the transmission operation.

The color legend below provides the “general” guidelines that were followed in assigning specific colors to the major components. However, due to the complexity of this transmission, some colors (such as grey) were used for artistic purposes rather than based on the specific function or location of that component.

-  Components that are stationary.
Examples: Converter Housing (102), Main Case (103), Oil Pump Assembly (4), Low and Reverse Clutch Support (679), Extension Housing (31).
-  Components that rotate at engine speed.
Examples: Torque Converter Cover and Pump, and the Oil Pump.
-  Components that rotate at turbine speed. Examples: Converter Turbine, Pressure Plate, Turbine Shaft and Input Housing Assembly (621).
-  Components that rotate at transmission output speed and other components. Examples: Reaction Internal Gear (684), Output Shaft (687), Speed Sensor Rotor (699), Forward Sprag Assembly (642), and Low and Reverse Roller Clutch Assembly (678).
-  Components such as the Stator in the Torque Converter (1), the Reverse Input Clutch Housing (605) and the Reaction Sun Shell (670).
-  Components such as the Reaction Carrier Assembly (681) and the Input Internal Gear (664).
-  Components such as the Overrun Clutch Hub (639) and the Forward Sprag Clutch Inner Race and Input Sun Gear Assembly (640).
-  All bearings, bushings, gaskets and spacer plates.
-  All seals

COLOR LEGEND

APPLY COMPONENTS

The Range Reference Chart on page 11, provides another valuable source of information for explaining the overall function of the Hydra-matic 4L60-E transmission. This chart highlights the major apply components that function in a selected gear range, and the specific gear operation within that gear range.

Included as part of this chart is the same color reference to each major component that was previously discussed. If a component is active in a specific gear range, a word describing its activity will be listed in the column below that component. The row where the activity occurs corresponds to the appropriate transmission range and gear operation.

An abbreviated version of this chart can also be found at the top of the half page of text located in the Power Flow section. This provides for a quick reference when reviewing the mechanical power flow information contained in that section.

RANGE REFERENCE CHART

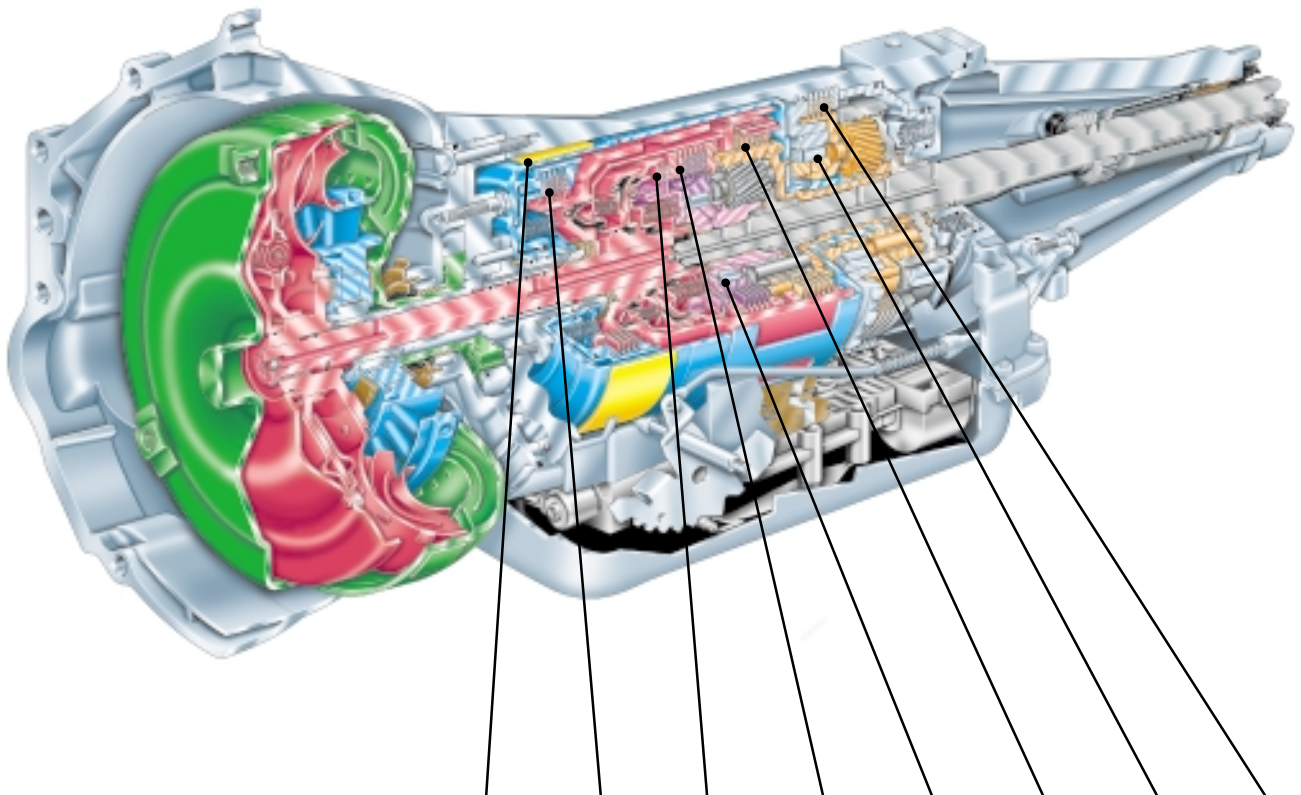

RANGE	GEAR	SHIFT SOLENOID VALVES		2-4 BAND	REVERSE INPUT CLUTCH	OVERRUN CLUTCH	FORWARD CLUTCH	FORWARD SPRAG CL. ASSEMBLY	3-4 CLUTCH	LO ROLLER CLUTCH	LO/REV. CLUTCH
		1-2	2-3								
PARK		ON*	ON*								APPLIED
REVERSE		ON*	ON*		APPLIED						APPLIED
NEUTRAL		ON*	ON*								
D	1st	ON	ON				APPLIED	HOLDING		HOLDING	
	2nd	OFF	ON	APPLIED			APPLIED	HOLDING			
	3rd	OFF	OFF				APPLIED	HOLDING	APPLIED		
	4th	ON	OFF	APPLIED			APPLIED		APPLIED		
3	1st	ON	ON				APPLIED	HOLDING		HOLDING	
	2nd	OFF	ON	APPLIED			APPLIED	HOLDING			
	3rd	OFF	OFF			APPLIED	APPLIED	HOLDING	APPLIED		
2 ***	1st **	ON	ON			APPLIED	APPLIED	HOLDING		HOLDING	
	2nd	OFF	ON	APPLIED		APPLIED	APPLIED	HOLDING			
1 ***	1st	ON	ON			APPLIED	APPLIED	HOLDING		HOLDING	APPLIED
	2nd	OFF	ON	APPLIED		APPLIED	APPLIED	HOLDING			

* 1-2 AND 2-3 SHIFT SOLENOID OPERATION AND THE SHIFT VALVE POSITIONING IN P, R, N RANGES ARE A FUNCTION OF THE INPUT TO THE SOLENOIDS FROM THE VSS. UNDER NORMAL OPERATING CONDITIONS THE SOLENOIDS ARE ON IN P, R, N.

** A MANUAL SECOND - FIRST GEAR CONDITION IS ONLY AVAILABLE ON SOME MODELS. OTHERWISE, THIS CONDITION IS ELECTRONICALLY PREVENTED.

*** IN MANUAL SECOND AND MANUAL FIRST, SOLENOID OPERATION IS A RESULT OF PCM CALIBRATION. SOME CALIBRATIONS WILL ALLOW ALL THREE GEARS UNDER EXTREME CONDITIONS.

Figure 10

TORQUE CONVERTER

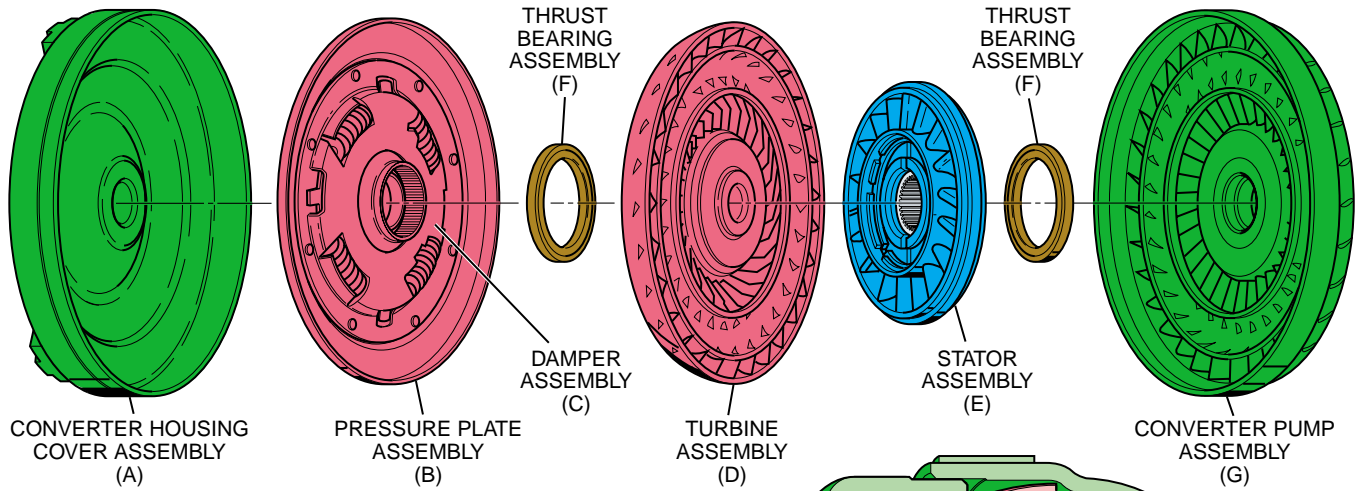

TORQUE CONVERTER:

The torque converter (1) is the primary component for transmittal of power between the engine and the transmission. It is bolted to the engine flywheel (also known as the flexplate) so that it will rotate at engine speed. Some of the major functions of the torque converter are:

- to provide for a smooth conversion of torque from the engine to the mechanical components of the transmission.
- to multiply torque from the engine that enables the vehicle to achieve additional performance when required.
- to mechanically operate the transmission oil pump (4) through the converter hub.
- to provide a mechanical link, or direct drive, from the engine to the transmission through the use of a torque converter clutch (TCC).

The torque converter assembly is made up of the following five main sub-assemblies:

- a converter housing cover assembly (A) which is welded to the converter pump assembly (G).
- a converter pump assembly (G) which is the driving member.
- a turbine assembly (D) which is the driven or output member.
- a stator assembly (E) which is the reaction member located between the converter pump and turbine assemblies.
- a pressure plate assembly (B) splined to the turbine assembly to enable direct mechanical drive when appropriate.

CONVERTER PUMP ASSEMBLY AND TURBINE ASSEMBLY

When the engine is running the converter pump assembly acts as a centrifugal pump by picking up fluid at its center and discharging it at its rim between the blades (see Figure 12). The force of this fluid then hits the turbine blades and causes the turbine to rotate. As the engine and converter pump increase in RPM, so does the turbine.

PRESSURE PLATE, DAMPER AND CONVERTER HOUSING ASSEMBLIES

The pressure plate is splined to the turbine hub and applies (engages) with the converter cover to provide a mechanical coupling of the engine to the transmission. When the pressure plate assembly is applied, the amount of slippage that occurs through a fluid coupling is reduced (but not eliminated), thereby providing a more efficient transfer of engine torque to the drive wheels.

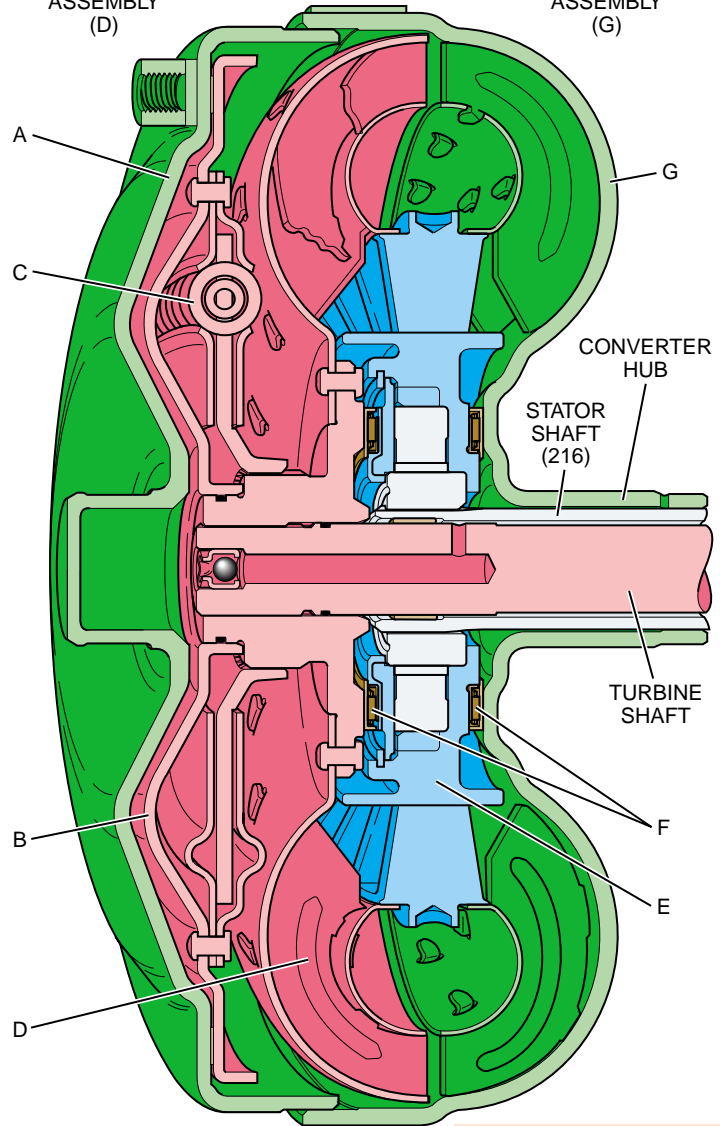

Torque converter failure could cause loss of drive and or loss of power.

To reduce torsional shock during the apply of the pressure plate to the converter cover, a spring loaded damper assembly (D) is used. The pressure plate is attached to the pivoting mechanism of the damper assembly which allows the pressure plate to rotate independently of the damper assembly up to approximately 45 degrees. During engagement, the springs in the damper assembly cushion the pressure plate engagement and also reduce irregular torque pulses from the engine or road surface.

TORQUE CONVERTER

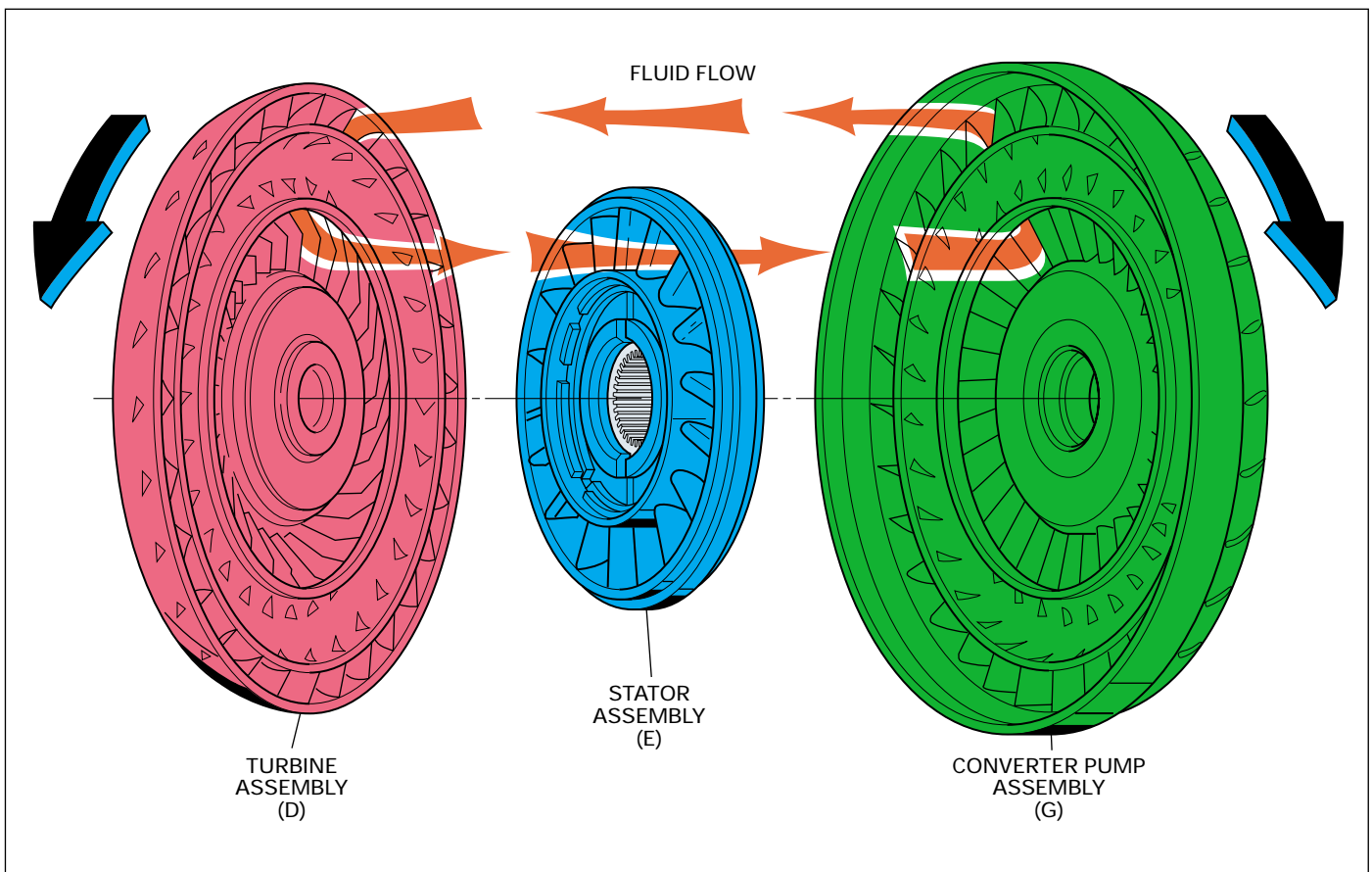

Figure 12

Stator roller clutch failure

- roller clutch freewheels in both directions can cause poor acceleration at low speed.
- roller clutch locks up in both directions can cause poor acceleration at high speed.
- Overheated fluid.

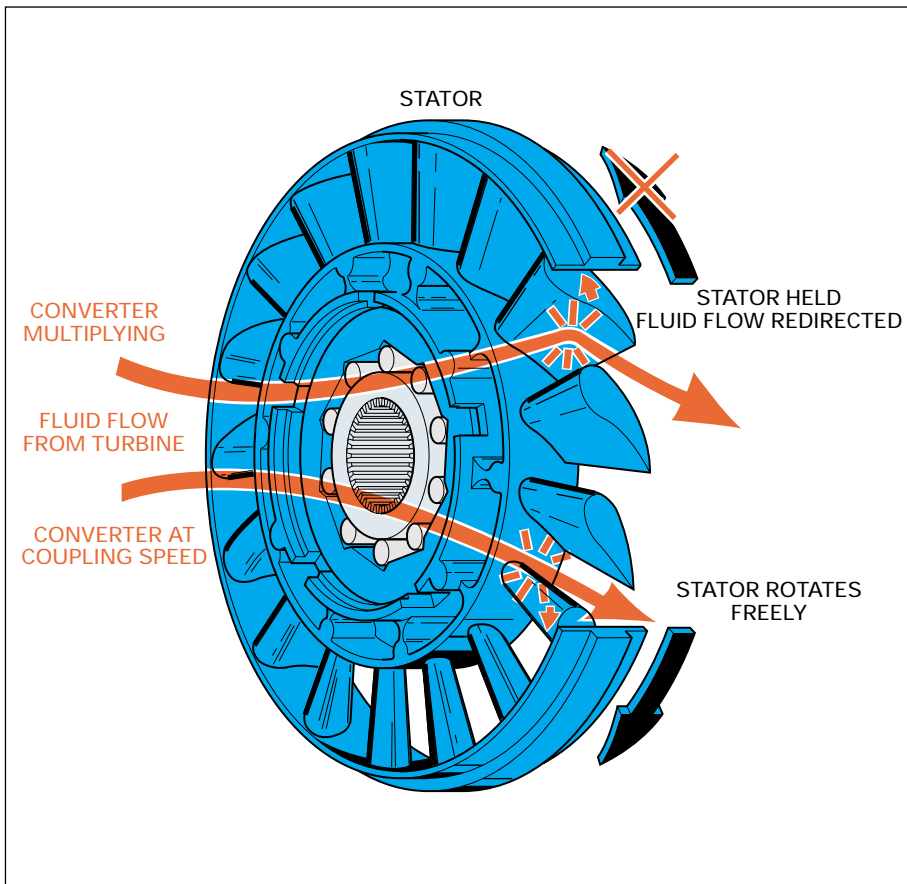

Figure 13

STATOR ASSEMBLY

The stator assembly is located between the pump assembly and turbine assembly, and is mounted on a one-way roller clutch. This one-way roller clutch allows the stator to rotate in one direction and prevents (holds) the stator from rotating in the other direction. The function of the stator is to redirect fluid returning from the turbine in order to assist the engine in turning the converter pump assembly.

At low vehicle speeds, when greater torque is needed, fluid from the turbine hits the front side of the stator blades (the converter is multiplying torque). At this time, the one-way roller clutch prevents the stator from rotating in the same direction as the fluid flow, thereby redirecting fluid to assist the engine in turning the converter pump. In this mode, fluid leaving the converter pump has more force to turn the turbine assembly and multiply engine torque.

As vehicle speed increases and less torque is required, centrifugal force acting on the fluid changes the direction of the fluid leaving the turbine such that it hits the back side of the stator blades (converter at coupling speed). When this occurs, the roller clutch overruns and allows the stator to rotate freely. Fluid is no longer being redirected to the converter pump and engine torque is not being multiplied.

TORQUE CONVERTER

RELEASE

When the torque converter clutch is released, fluid is fed into the torque converter by the pump into the release fluid passage. The release fluid passage is located between the stator shaft (214) and the turbine shaft (621). Fluid travels between the shafts and enters the release side of the pressure plate at the end of the turbine shaft. The pressure plate is forced away from the converter cover and allows the torque converter turbine to rotate at speeds other than engine speed.

The release fluid then flows between the friction element on the pressure plate and the converter cover to enter the apply side of the torque converter. The fluid then exits the torque converter through the apply passage, which is located between the torque converter clutch hub and the stator shaft (214), and enters the pump.

No TCC apply can be caused by:

- Electrical connectors, wiring harness or solenoid damaged
- Converter clutch valve stuck or assembled backwards
- Pump to case gasket mispositioned
- Orifice cup plug restricted or damaged
- Solenoid O-ring seal cut or damaged
- Turbine shaft O-ring seal cut or damaged
- Turbine shaft retainer and ball assembly restricted or damaged
- Control valve body TCC signal valve stuck
- Solenoid screen blocked
- TCC solenoid valve internal damage
- Engine speed sensor internal damage

APPLY

When the PCM determines that the vehicle is at the proper speed for the torque converter clutch to apply it sends a signal to the TCC (PWM) solenoid valve. The TCC (PWM) solenoid valve then regulates line fluid from the pump into the regulated apply passage. The regulated apply fluid then feeds the apply fluid passage and applies the torque converter. The apply passage is located between the turbine shaft and the stator shaft. The fluid flows between the shafts, then passes into the torque converter on the apply side of the pressure plate assembly. Release fluid is then routed out of the torque converter between the turbine shaft and the stator shaft.

Apply fluid pressure forces the pressure plate against the torque converter cover to provide a mechanical link between the engine and the turbine.

The TCC apply should occur in fourth gear (also third gear in some applications), and should not apply until the transmission fluid has reached a minimum operating temperature of 8°C (46°F) and the engine coolant temperature reaches 50°C (122°F).

For more information on TCC apply and release, see *Overdrive Range – Fourth Gear TCC Released and Applied*, pages 62–63.

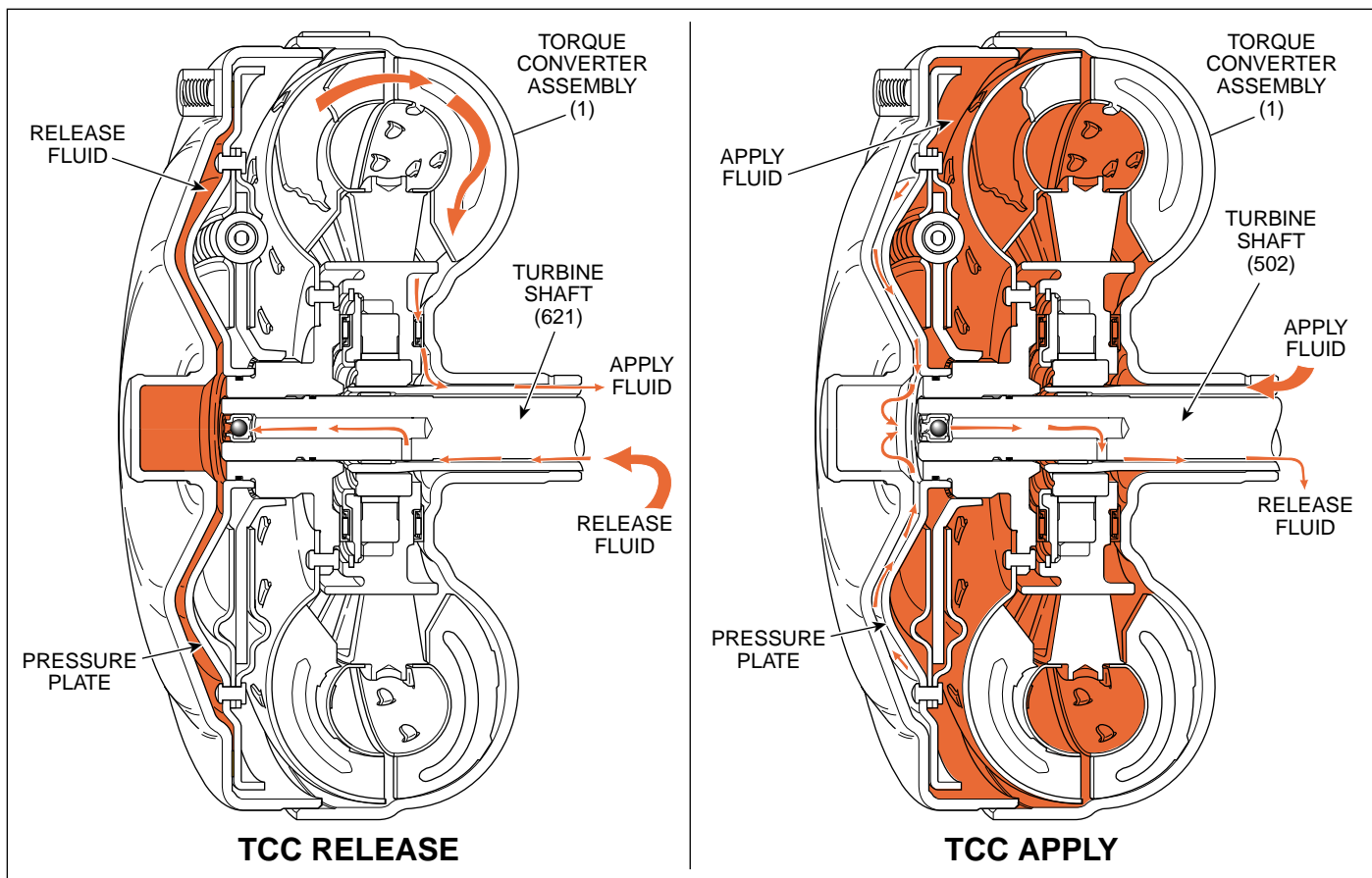

APPLY COMPONENTS

The Apply Components section is designed to explain the function of the hydraulic and mechanical holding devices used in the Hydra-matic 4L60-E transmission. Some of these apply components, such as clutches and bands, are hydraulically “applied” and “released” in order to provide automatic gear range shifting. Other components, such as a roller clutch or sprag clutch, often react to a hydraulically “applied” component by mechanically “holding” or “releasing” another member of the transmission. This interaction between the hydraulically and mechanically applied components is then explained in detail and supported with a graphic illustration. In addition, this section shows the routing of fluid pressure to the individual components and their internal functions when it applies or releases.

The sequence in which the components in this section have been discussed coincides with their physical arrangement inside the transmission. This order closely parallels the disassembly sequence used in the Hydra-matic 4L60-E Unit Repair Section located in Section 7 of the appropriate Service Manual. It also correlates with the components shown on the Range Reference Charts that are used throughout the Power Flow section of this book. The correlation of information between the sections of this book helps the user more clearly understand the hydraulic and mechanical operating principles for this transmission.

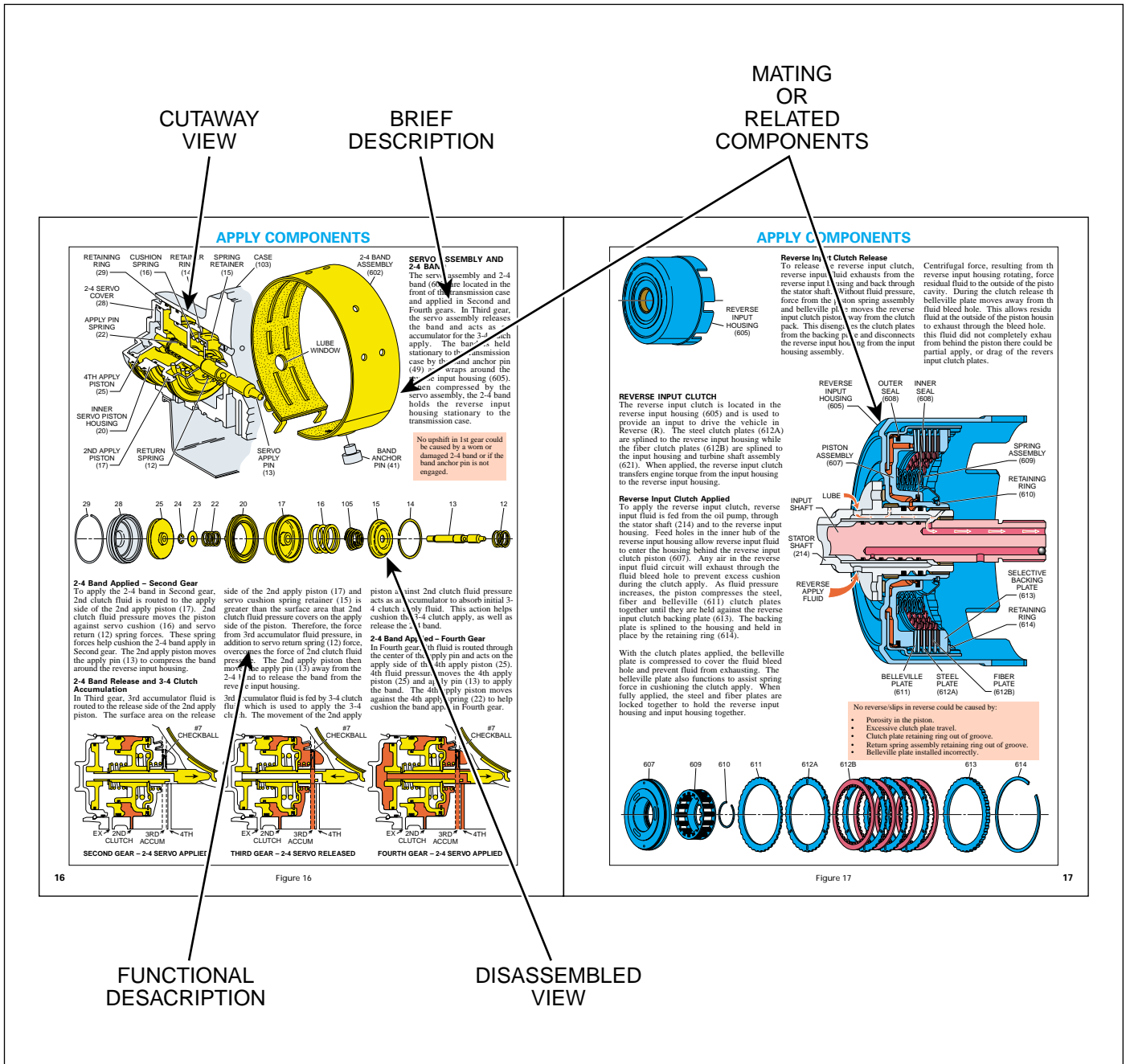
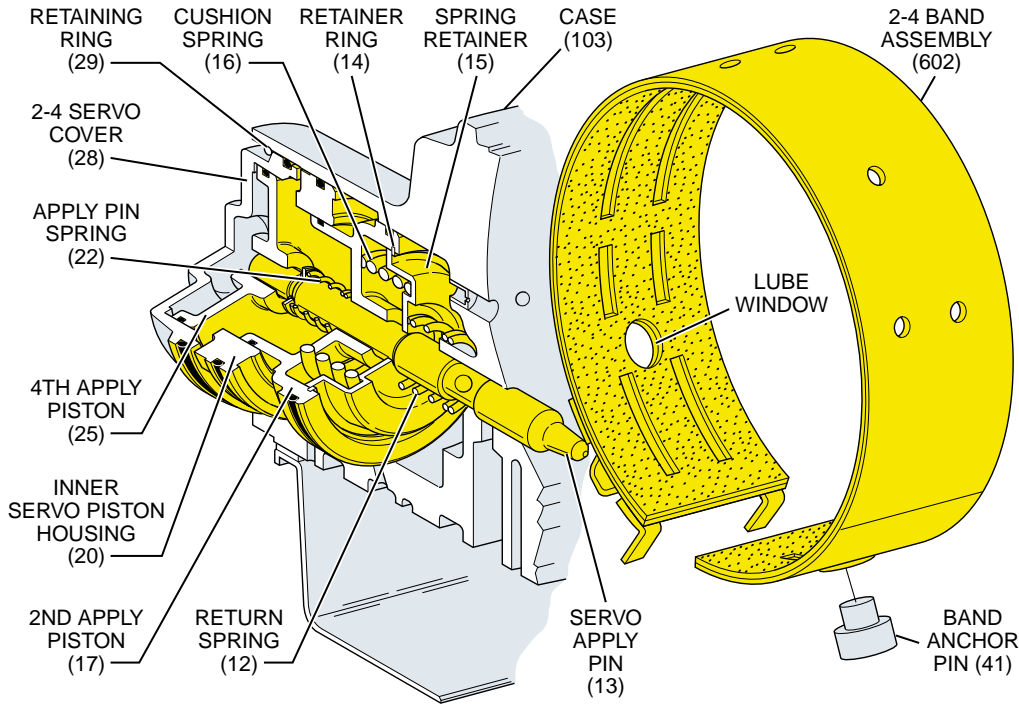

Figure 15

APPLY COMPONENTS



SERVO ASSEMBLY AND 2-4 BAND

The servo assembly and 2-4 band (602) are located in the front of the transmission case and applied in Second and Fourth gears. In Third gear, the servo assembly releases the band and acts as an accumulator for the 3-4 clutch apply. The band is held stationary to the transmission case by the band anchor pin (49) and wraps around the reverse input housing (605). When compressed by the servo assembly, the 2-4 band holds the reverse input housing stationary to the transmission case.

No upshift in 1st gear could be caused by a worn or damaged 2-4 band or if the band anchor pin is not engaged.

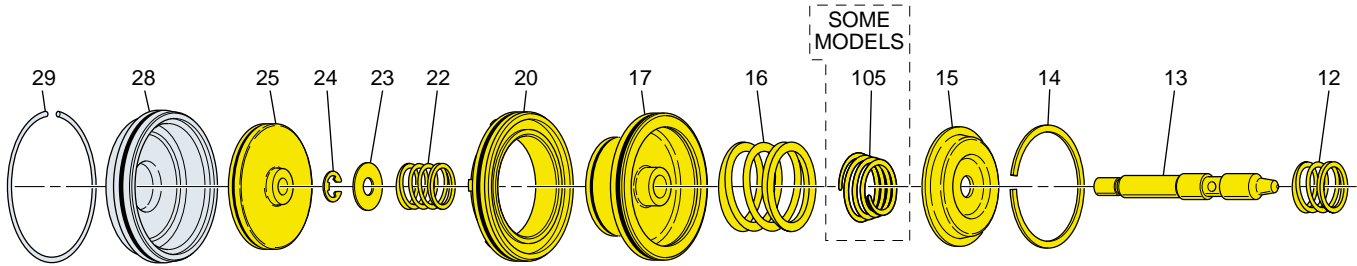

2-4 Band Applied – Second Gear

To apply the 2-4 band in Second gear, 2nd clutch fluid is routed to the apply side of the 2nd apply piston (17). 2nd clutch fluid pressure moves the piston against servo cushion (16) and servo return (12) spring forces. These spring forces help cushion the 2-4 band apply in Second gear. The 2nd apply piston moves the apply pin (13) to compress the band around the reverse input housing.

2-4 Band Release and 3-4 Clutch Accumulation

In Third gear, 3rd accumulator fluid is routed to the release side of the 2nd apply piston. The surface area on the release

side of the 2nd apply piston (17) and servo cushion spring retainer (15) is greater than the surface area that 2nd clutch fluid pressure covers on the apply side of the piston. Therefore, the force from 3rd accumulator fluid pressure, in addition to servo return spring (12) force, overcomes the force of 2nd clutch fluid pressure. The 2nd apply piston then moves the apply pin (13) away from the 2-4 band to release the band from the reverse input housing.

3rd accumulator fluid is fed by 3-4 clutch fluid which is used to apply the 3-4 clutch. The movement of the 2nd apply

piston against 2nd clutch fluid pressure acts as an accumulator to absorb initial 3-4 clutch apply fluid. This action helps cushion the 3-4 clutch apply, as well as release the 2-4 band.

2-4 Band Applied – Fourth Gear

In Fourth gear, 4th fluid is routed through the center of the apply pin and acts on the apply side of the 4th apply piston (25). 4th fluid pressure moves the 4th apply piston and apply pin (13) to apply the band. The 4th apply piston moves against the 4th apply spring (22) to help cushion the band apply in Fourth gear.

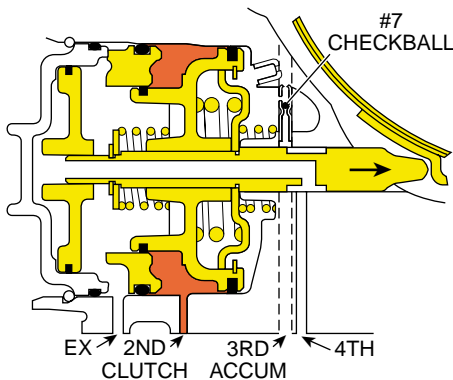

SECOND GEAR – 2-4 SERVO APPLIED

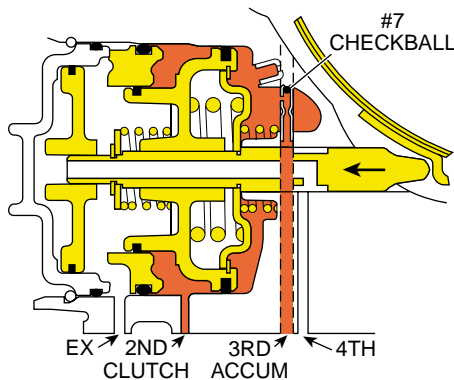

THIRD GEAR – 2-4 SERVO RELEASED

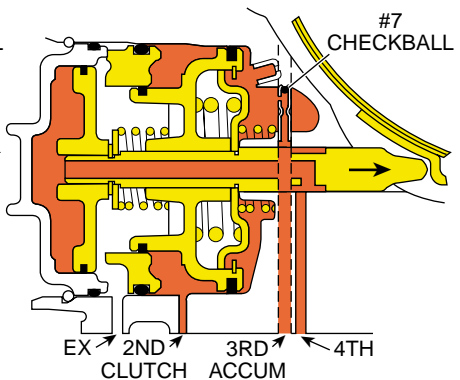

FOURTH GEAR – 2-4 SERVO APPLIED

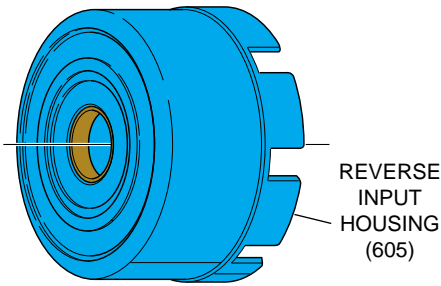

Reverse Input Clutch Release

To release the reverse input clutch, reverse input fluid exhausts from the reverse input housing and back through the stator shaft. Without fluid pressure, force from the piston spring assembly and belleville plate moves the reverse input clutch piston away from the clutch pack. This disengages the clutch plates from the backing plate and disconnects the reverse input housing from the input housing assembly.

Centrifugal force, resulting from the reverse input housing rotating, forces residual fluid to the outside of the piston cavity. During the clutch release the belleville plate moves away from the fluid bleed hole. This allows residual fluid at the outside of the piston housing to exhaust through the bleed hole. If this fluid did not completely exhaust from behind the piston there could be a partial apply, or drag of the reverse input clutch plates.

REVERSE INPUT CLUTCH

The reverse input clutch is located in the reverse input housing (605) and is used to provide an input to drive the vehicle in Reverse (R). The steel clutch plates (612A) are splined to the reverse input housing while the fiber clutch plates (612B) are splined to the input housing and turbine shaft assembly (621). When applied, the reverse input clutch transfers engine torque from the input housing to the reverse input housing.

Reverse Input Clutch Applied

To apply the reverse input clutch, reverse input fluid is fed from the oil pump, through the stator shaft (214) and to the reverse input housing. Feed holes in the inner hub of the reverse input housing allow reverse input fluid to enter the housing behind the reverse input clutch piston (607). Any air in the reverse input fluid circuit will exhaust through the fluid bleed hole to prevent excess cushion during the clutch apply. As fluid pressure increases, the piston compresses the steel, fiber and belleville (611) clutch plates together until they are held against the reverse input clutch backing plate (613). The backing plate is splined to the housing and held in place by the retaining ring (614).

With the clutch plates applied, the belleville plate is compressed to cover the fluid bleed hole and prevent fluid from exhausting. The belleville plate also functions to assist spring force in cushioning the clutch apply. When fully applied, the steel and fiber plates are locked together to hold the reverse input housing and input housing together.

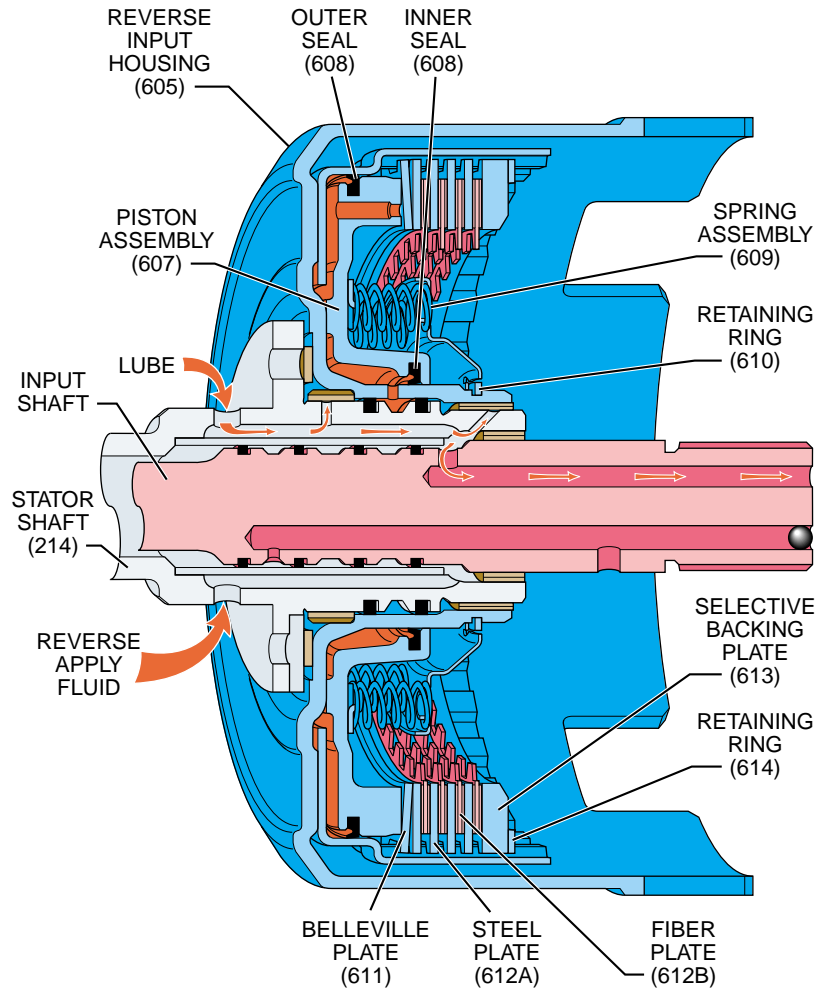

No reverse/slips in reverse could be caused by:

- Porosity in the piston.
- Excessive clutch plate travel.
- Clutch plate retaining ring out of groove.
- Return spring assembly retaining ring out of groove.
- Belleville plate installed incorrectly.

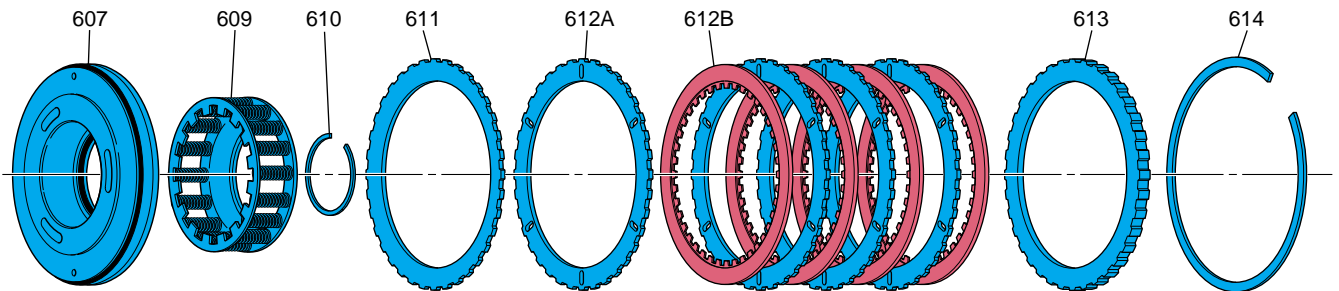
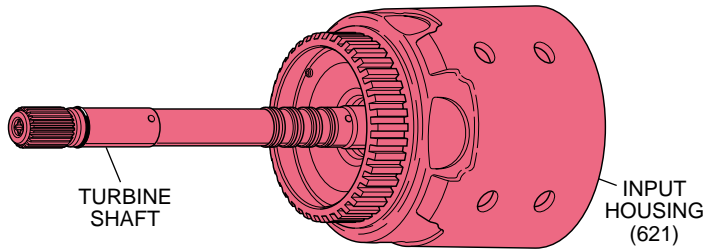

Figure 17



away from the clutch pack. This disengages the clutch plates from the forward clutch apply plate and disconnects the overrun clutch hub from the input housing.

During the exhaust of overrun clutch fluid, the overrun clutch checkball unseats (see illustration). Centrifugal force, resulting from the input housing rotating, forces residual overrun clutch fluid to the outside of the piston housing and past the unseated checkball. If this fluid did not completely exhaust from behind the piston there could be a partial apply, or drag of the overrun clutch plates.

OVERRUN CLUTCH

The overrun clutch assembly is located in the input housing and turbine shaft assembly (621) and is only applied in the Manual Gear ranges. The steel clutch plates (645A) are splined to the input housing while the fiber clutch plates (645B) are splined to the overrun clutch hub (639). When applied, the overrun clutch plates force the overrun clutch hub to rotate at the same speed as the input housing. This prevents the forward sprag clutch from being overrun during coast conditions, thereby providing engine compression braking to slow the vehicle.

Overrun Clutch Applied

To apply the overrun clutch, overrun clutch fluid is routed through the turbine shaft and into the input housing behind the overrun clutch piston (632). Overrun clutch fluid pressure seats the overrun clutch checkball (633), which is located in the overrun clutch piston, and moves the piston to compress the overrun

OVERRUN CLUTCH CHECKBALL

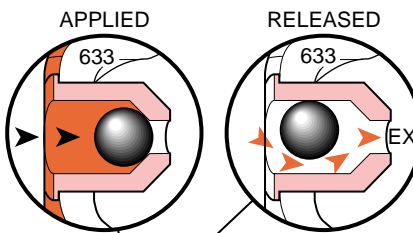

OVERRUN CLUTCH PISTON (632)
STEEL CLUTCH PLATE (645A)
FIBER CLUTCH PLATE (645B)

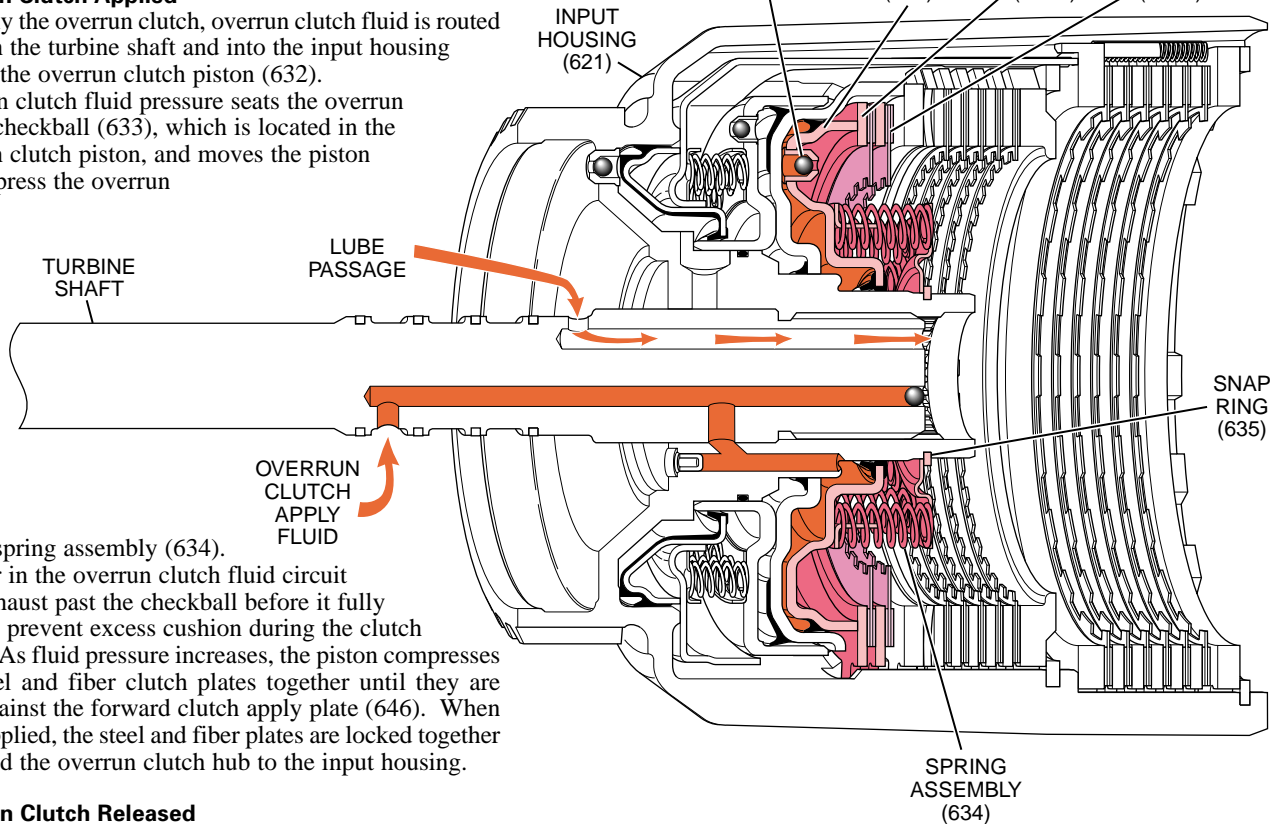

clutch spring assembly (634).

Any air in the overrun clutch fluid circuit will exhaust past the checkball before it fully seats to prevent excess cushion during the clutch apply. As fluid pressure increases, the piston compresses the steel and fiber clutch plates together until they are held against the forward clutch apply plate (646). When fully applied, the steel and fiber plates are locked together and hold the overrun clutch hub to the input housing.

Overrun Clutch Released

To release the overrun clutch, overrun clutch fluid exhausts from the input housing and back through the turbine shaft. Without fluid pressure, force from the piston spring assembly moves the overrun clutch piston

Overrun piston checkball not sealing or overrun piston seals cut or damaged can cause no overrun braking - manual 3-2-1.

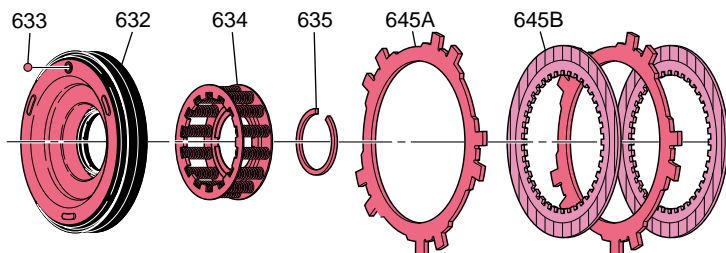
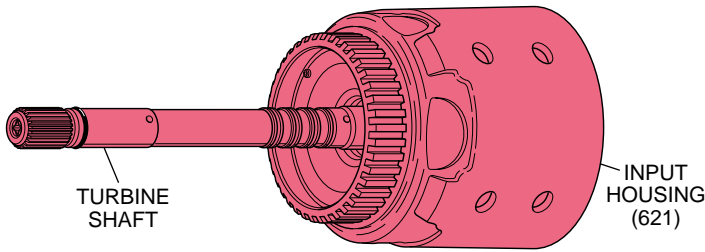

Figure 18

APPLY COMPONENTS



forward clutch piston away from the clutch pack. This disengages the clutch plates from the backing plate and disconnects the input housing from the forward clutch outer race.

During the exhaust of forward clutch feed fluid, the forward clutch housing checkball unseats (see illustration). Centrifugal force, resulting from the input housing rotating, forces residual forward clutch feed fluid to the outside of the piston housing and past the unseated checkball. If this fluid did not completely exhaust from behind the piston there could be a partial apply, or drag of the forward clutch plates.

FORWARD CLUTCH

The forward clutch assembly is located in the input housing and turbine shaft assembly (621) and is applied in all forward drive ranges. The steel clutch plates (649A) are splined to the input housing while the fiber clutch plates (649B) are splined to the forward clutch outer race (644). When applied, the forward clutch plates transfer engine torque from the input housing to the forward clutch outer race and forward sprag clutch assembly.

Forward Clutch Applied

To apply the forward clutch, forward clutch feed fluid is routed through the turbine shaft and into the input housing behind the forward clutch piston (630). Forward clutch feed fluid pressure seats the forward clutch housing checkball, which is located in the forward clutch housing (627), and moves the piston to compress the piston spring assembly (634). Any air in the forward clutch feed fluid circuit will exhaust past the checkball before it fully seats to prevent excess cushion during the clutch apply. As fluid pressure increases, the piston moves the apply plate (646) and compresses

FORWARD CLUTCH HOUSING CHECKBALL

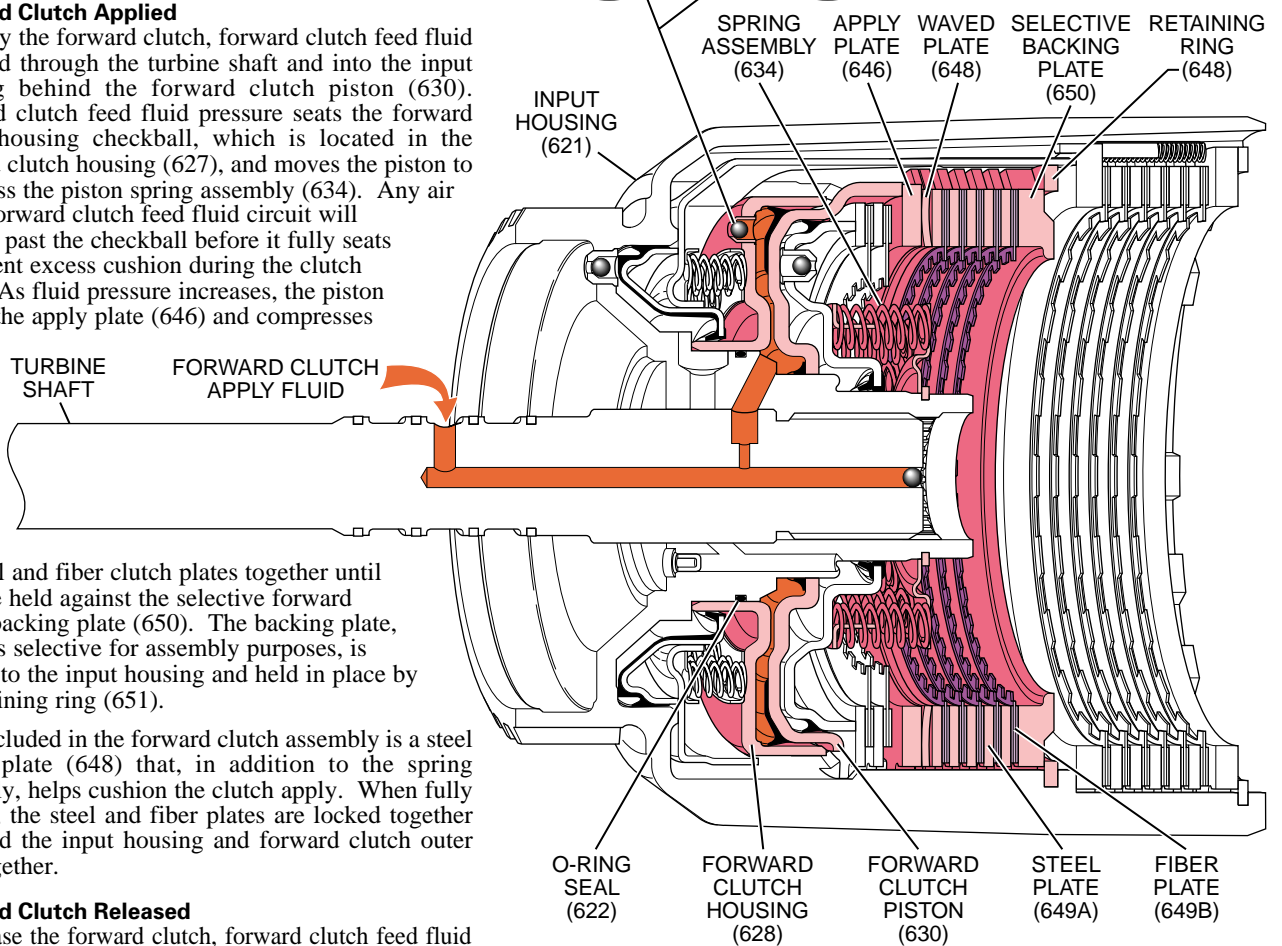
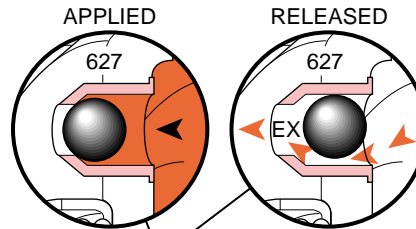

the steel and fiber clutch plates together until they are held against the selective forward clutch backing plate (650). The backing plate, which is selective for assembly purposes, is splined to the input housing and held in place by the retaining ring (651).

Also included in the forward clutch assembly is a steel waved plate (648) that, in addition to the spring assembly, helps cushion the clutch apply. When fully applied, the steel and fiber plates are locked together and hold the input housing and forward clutch outer race together.

Forward Clutch Released

To release the forward clutch, forward clutch feed fluid exhausts from the input housing and back through the turbine shaft. Without fluid pressure, force from the piston spring assembly and waved plate moves the

Worn forward clutch plates, damaged forward clutch housing, damaged or missing forward clutch piston seals, or porosity in forward clutch piston can cause slips in 1st gear.

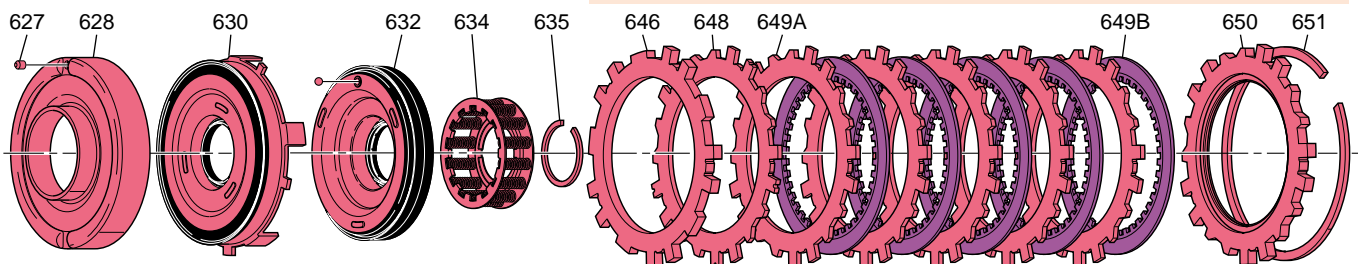
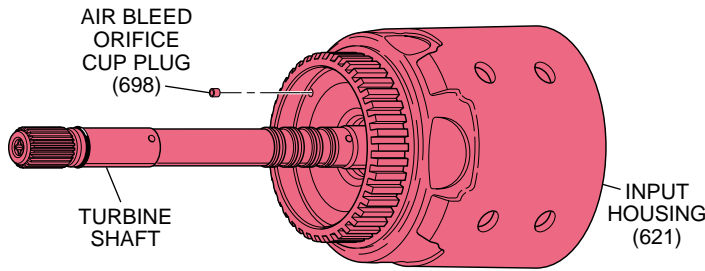

Figure 19

APPLY COMPONENTS



backing plate and disconnects the input housing from the forward clutch outer race.

During the exhaust of 3-4 clutch fluid, the 3-4 clutch checkball unseats (see illustration). Centrifugal force, resulting from the input housing rotating, forces residual 3-4 clutch fluid to the outside of the piston housing and past the unseated checkball. If this fluid did not completely exhaust from behind the piston there could be a partial apply, or drag of the 3-4 clutch plates.

3-4 accumulator piston seal or seal groove damage or porosity in the 3-4 accumulator piston or bore can cause no 3-4 shift/slips or rough 3-4 shift.

3-4 CLUTCH

The 3-4 clutch assembly is located in the input housing and turbine shaft assembly (621) and is applied in Third and Fourth gears. The steel clutch plates (654B/C) are splined to the input housing while the fiber clutch plates (654A) are splined to the input internal gear (664). When applied, the 3-4 clutch plates transfer engine torque from the input housing to the input internal gear.

3-4 Clutch Applied

To apply the 3-4 clutch, 3-4 clutch fluid is routed through the turbine shaft and into the input housing behind the 3-4 clutch piston (623). 3-4 clutch fluid pressure seats the 3-4 clutch checkball (620), which is located in the input housing, and moves the piston against the 3-4 clutch apply ring (625). The apply ring compresses the 3-4 clutch spring assembly (626) which helps cushion the 3-4 clutch apply. Any air in the 3-4 clutch fluid circuit will exhaust past the 3-4 clutch checkball before it fully seats to prevent excess cushion during the clutch apply.

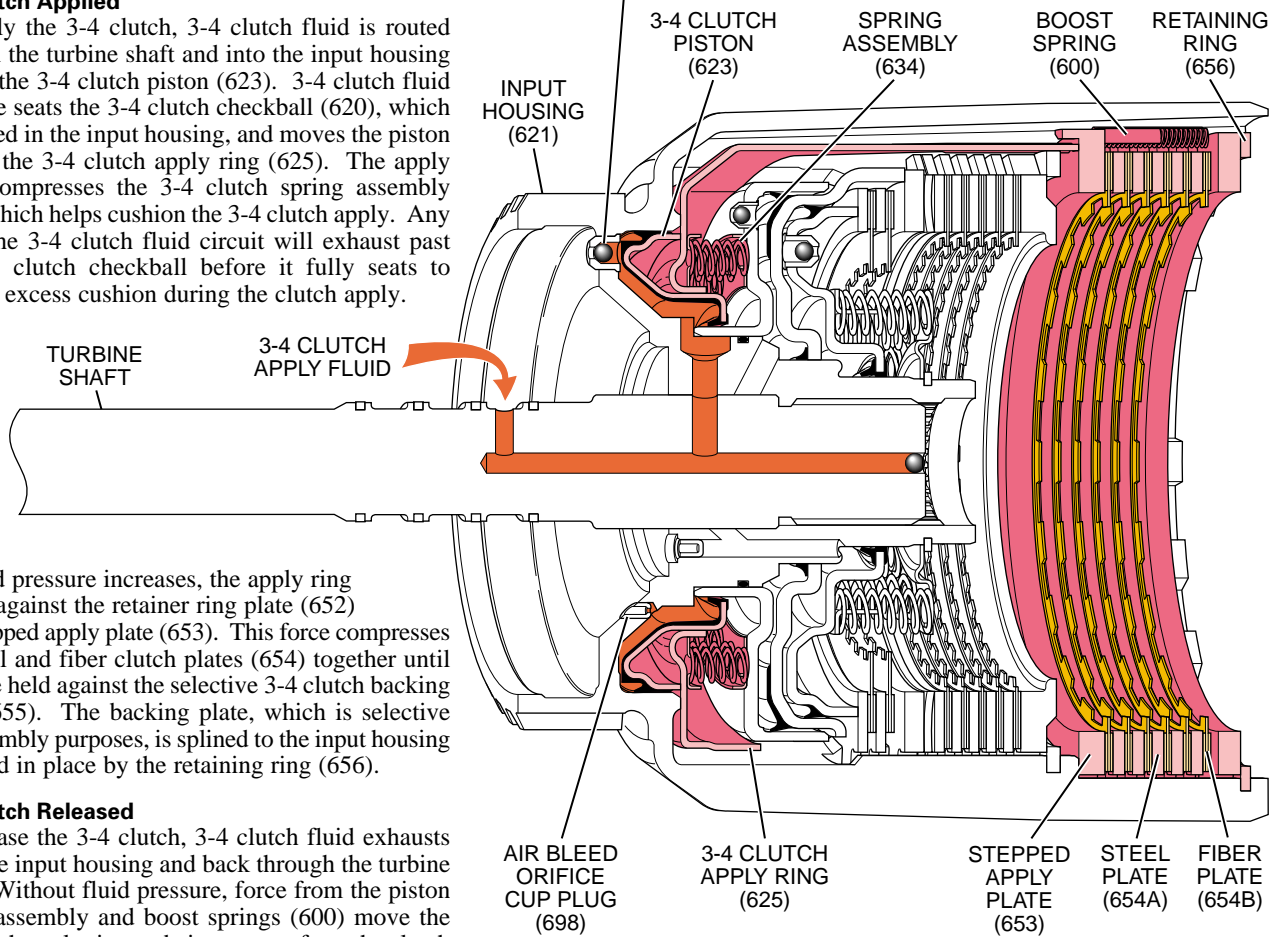
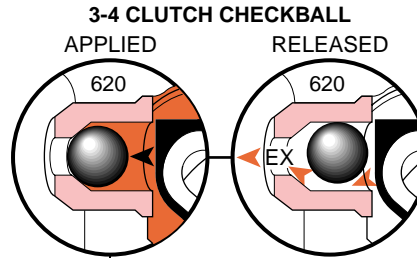

As fluid pressure increases, the apply ring moves against the retainer ring plate (652) and stepped apply plate (653). This force compresses the steel and fiber clutch plates (654) together until they are held against the selective 3-4 clutch backing plate (655). The backing plate, which is selective for assembly purposes, is splined to the input housing and held in place by the retaining ring (656).

3-4 Clutch Released

To release the 3-4 clutch, 3-4 clutch fluid exhausts from the input housing and back through the turbine shaft. Without fluid pressure, force from the piston spring assembly and boost springs (600) move the 3-4 clutch apply ring and piston away from the clutch pack. This disengages the clutch plates from the

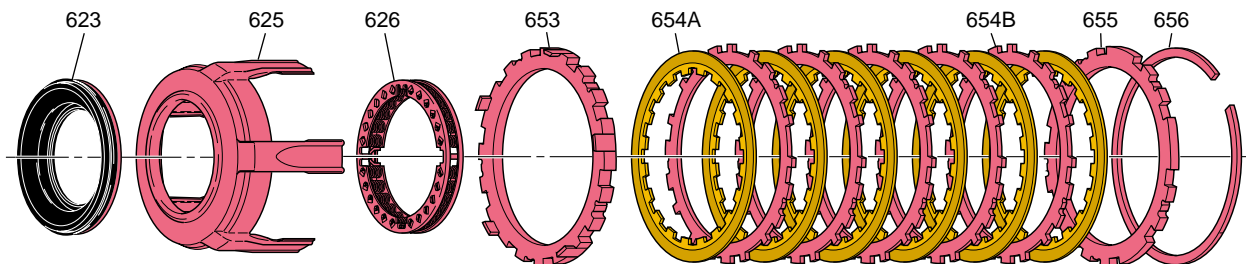
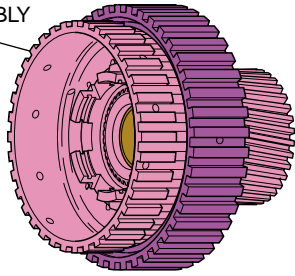

Figure 20

FORWARD CLUTCH SPRAG ASSEMBLY (638-644)



FORWARD SPRAG CLUTCH ASSEMBLY

The forward sprag clutch assembly (642) is located between the forward clutch race (644) and the inner race and input sun gear assembly (640). The inner race and input sun gear assembly is connected to the overrun clutch hub (639) while the forward clutch race is splined to the forward clutch plates. The sprag clutch is a type of one-way clutch that transfers engine torque from the forward clutch to the input sun gear during acceleration in First, Second and Third gears in Overdrive Range. When the throttle is released in these gear ranges the sprag clutch is overrun to allow the vehicle to coast freely.

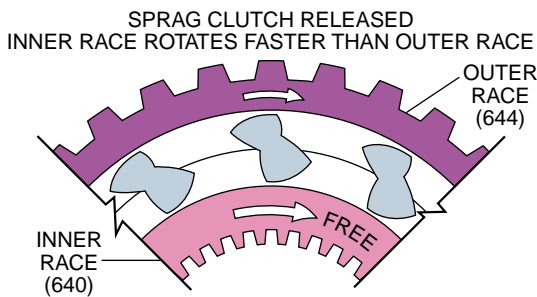
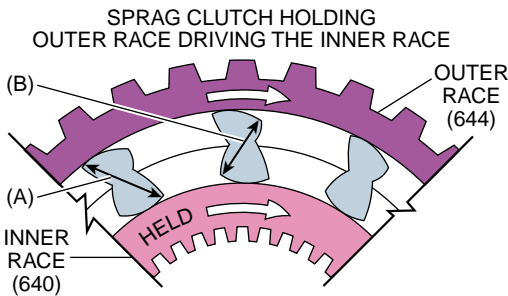

Forward Sprag Clutch Holding

When the forward clutch is applied, engine torque is transferred to the forward clutch race (644) which functions as the outer race for the sprag assembly. The rotation of the outer race pivots the sprags toward their long diagonals. The length of the long diagonal (distance A) is greater than the distance between the outer race and inner race (640). This causes the sprags to "lock" between the inner and outer races and transfer engine torque from the forward clutch race to the inner race and input sun gear assembly (640).

Forward Sprag Clutch Released

The sprag clutch releases when the sprags pivot toward their short diagonals. The length of the short diagonals (B) is less than the distance between the inner and outer sprag races. This occurs when power flow drives the input sun gear and sprag race and retainer assembly faster than the forward clutch drives the forward clutch race (644). During acceleration the sprag clutch is overrun only in Fourth gear.

Coast Conditions

The sprag clutch is also overrun during coast conditions, or deceleration, in the following gear ranges:

- Overdrive Range - First, Second and Third Gears
- Manual Third - First and Second Gears
- Manual Second - First Gear

During coast conditions, power from vehicle speed drives the input sun gear faster than engine torque drives the forward clutch race (644). In this situation, the inner race and input sun gear assembly (640) overruns the sprag clutch and allows the vehicle to coast freely.

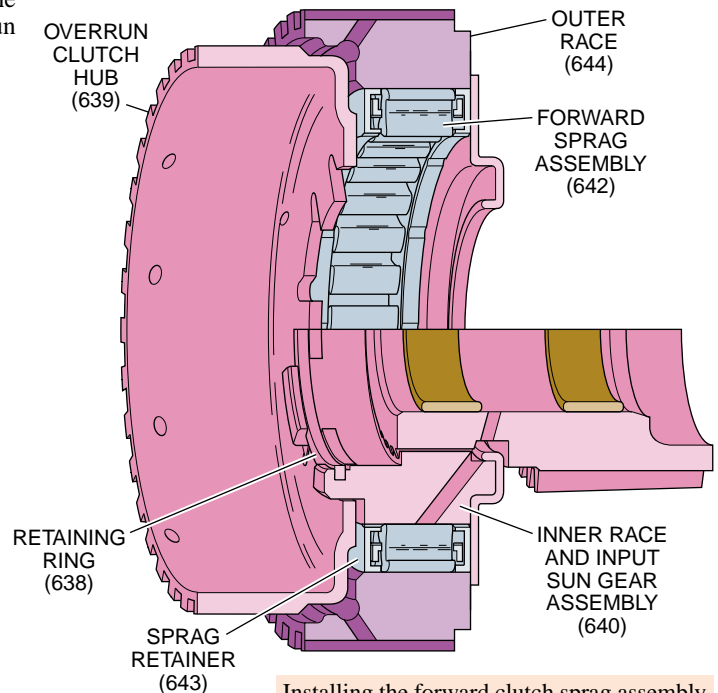

Installing the forward clutch sprag assembly backwards can cause second gear starts.

Overrun Clutch Applied

When the overrun clutch is applied (see range reference chart) it holds the overrun clutch hub and sun gear together. These components are then forced to rotate at the same speed as the input housing. This prevents the input sun gear from being driven faster than the forward clutch race (644). During coast conditions when the throttle is released, power from vehicle speed is then transferred back to the torque converter and engine compression slows the vehicle.

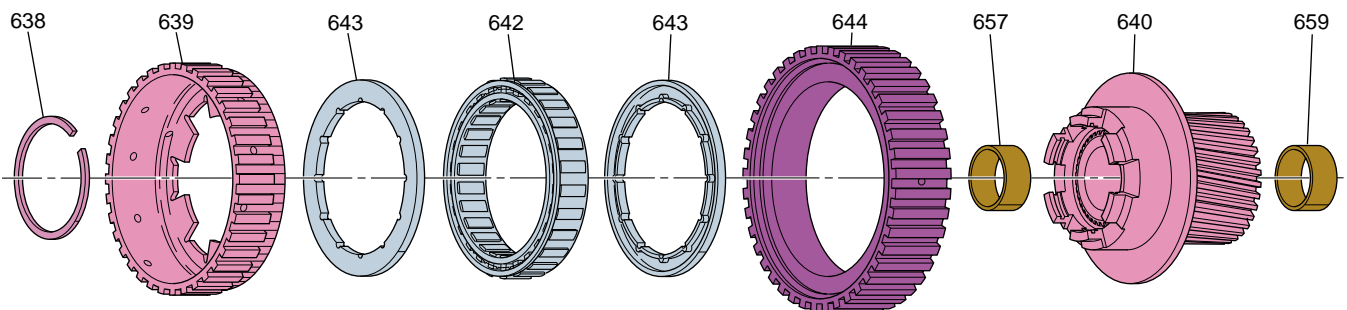
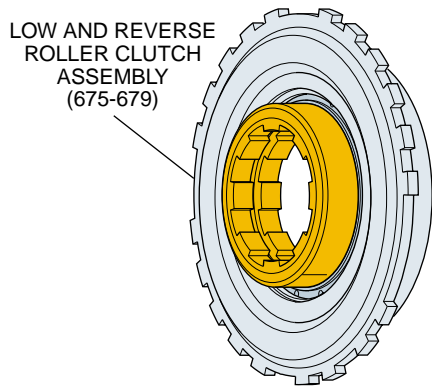

Figure 21



Roller Clutch Released

The roller clutch is overrun by the reaction carrier assembly and inner race when the throttle is released during First gear operation with the selector lever in Overdrive, Manual Third and Manual Second. When the throttle is released, power flow from vehicle speed drives the reaction carrier assembly and inner race in a clockwise direction. The inner race moves the rollers down the ramp, overruns the rollers and rotates freely in a clockwise direction.

Lube passage plugged, damage to inner splines, or inadequate spring tension in the low roller clutch can cause slips in 1st gear.

LOW AND REVERSE ROLLER CLUTCH

The low and reverse roller clutch (678) is a type of one-way clutch used to prevent the reaction carrier assembly (681), reaction carrier shaft (666) and input internal gear (664) from rotating in a counterclockwise direction. The roller clutch is located between the low and reverse clutch support (679) and the low roller clutch race (675). The low roller clutch support functions as the outer cam for the roller clutch and is splined to the transmission case. The roller clutch race (675) is splined to the reaction carrier assembly (681) and functions as the roller clutch inner race.

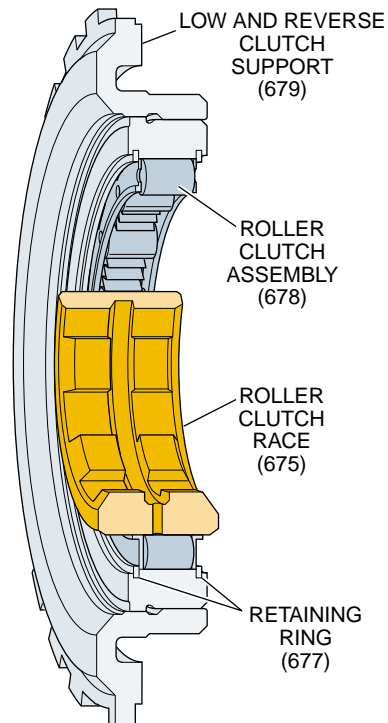

ROLLER CLUTCH HOLDING

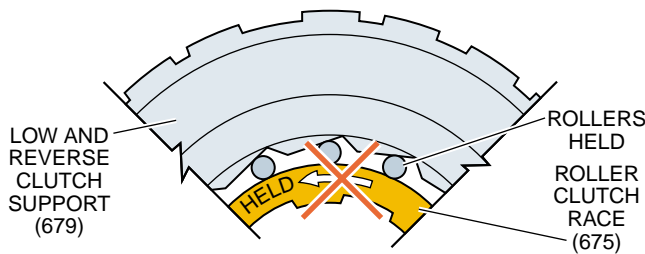

ROLLER CLUTCH RELEASED

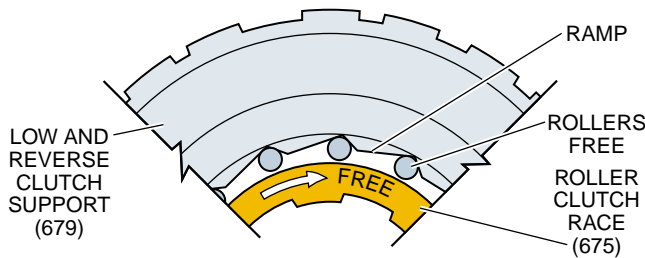

Roller Clutch Holding

The roller clutch is holding during acceleration in First gear. When accelerating in First gear, the reaction carrier assembly and inner race (675) attempt to rotate counterclockwise. This action causes the rollers to roll up the ramps on the outer cam and wedge between the inner race and outer cam. With the rollers wedged and the low and reverse clutch support held stationary to the transmission case, the reaction carrier assembly is also held stationary.

Low and Reverse Clutch Applied

In Manual First – First Gear, the low and reverse clutch is applied to hold the reaction carrier assembly stationary to the transmission case. The low and reverse clutch prevents the reaction carrier and inner race from rotating clockwise and overrunning the roller clutch when the throttle is released. Power flow is then transferred back through the transmission gear sets and to the torque converter, allowing engine compression to slow the vehicle. The low and reverse clutch is also applied in Reverse to provide the necessary power flow to obtain Reverse.

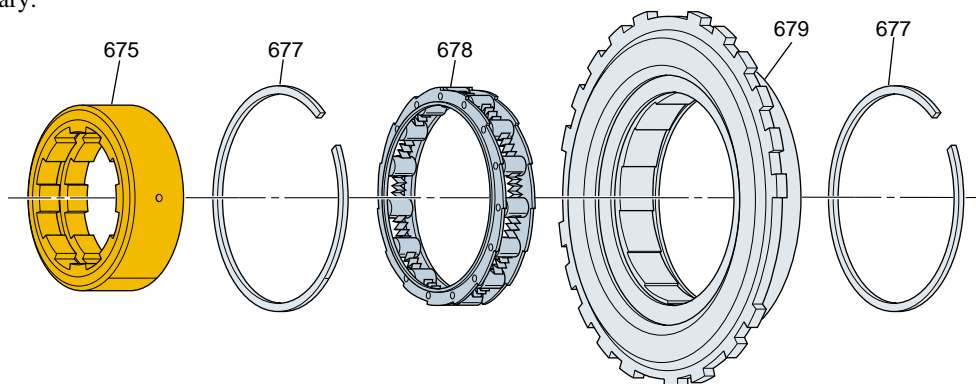

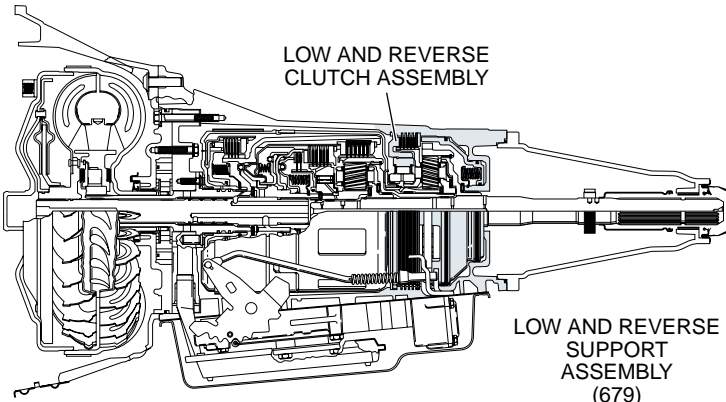

Low and Reverse Clutch Released

To release the low and reverse clutch, apply fluid pressure exhausts from the behind the low and reverse clutch piston. When exhausting, PR fluid unseats the PR checkball (42) for a quick exhaust. Without fluid pressure, force from the piston spring assembly and waved plate moves the low and reverse clutch piston away from the clutch pack. This disengages the clutch plates from the low and reverse clutch support, thereby allowing the reaction carrier assembly to rotate freely.

LOW AND REVERSE CLUTCH

The low and reverse clutch assembly is located in the rear of the transmission case and is applied in Park, Reverse and Manual First – First Gear. The steel clutch plates (682A,B,D) are splined to the transmission case while the fiber clutch plates (682C) are splined to the reaction planetary carrier (681). When applied, the low and reverse clutch plates hold the reaction planetary carrier stationary to the transmission case.

Low and Reverse Clutch Applied

To apply the low and reverse clutch, two different fluids are routed to the low and reverse clutch piston (695). In Manual First, lo/reverse fluid is routed to the inner area of the clutch piston. In Park and Reverse, PR fluid is routed to the outer area of the low and reverse clutch piston, in addition to lo/reverse fluid acting on the inner area of the piston, to provide a greater holding capacity of the clutch. Fluid pressure moves the piston to compress the low and reverse clutch piston spring assembly (634). PR fluid seats the PR checkball and is orificed to the piston to help control the clutch apply. Also included in the forward clutch assembly is a steel waved plate (682A) that, in addition to the spring assembly, helps cushion the clutch apply. As fluid pressure increases, the piston compresses the steel and fiber clutch plates together until they are held against the low and reverse support assembly (679). The spacer plate (682B) is selective for assembly purposes.

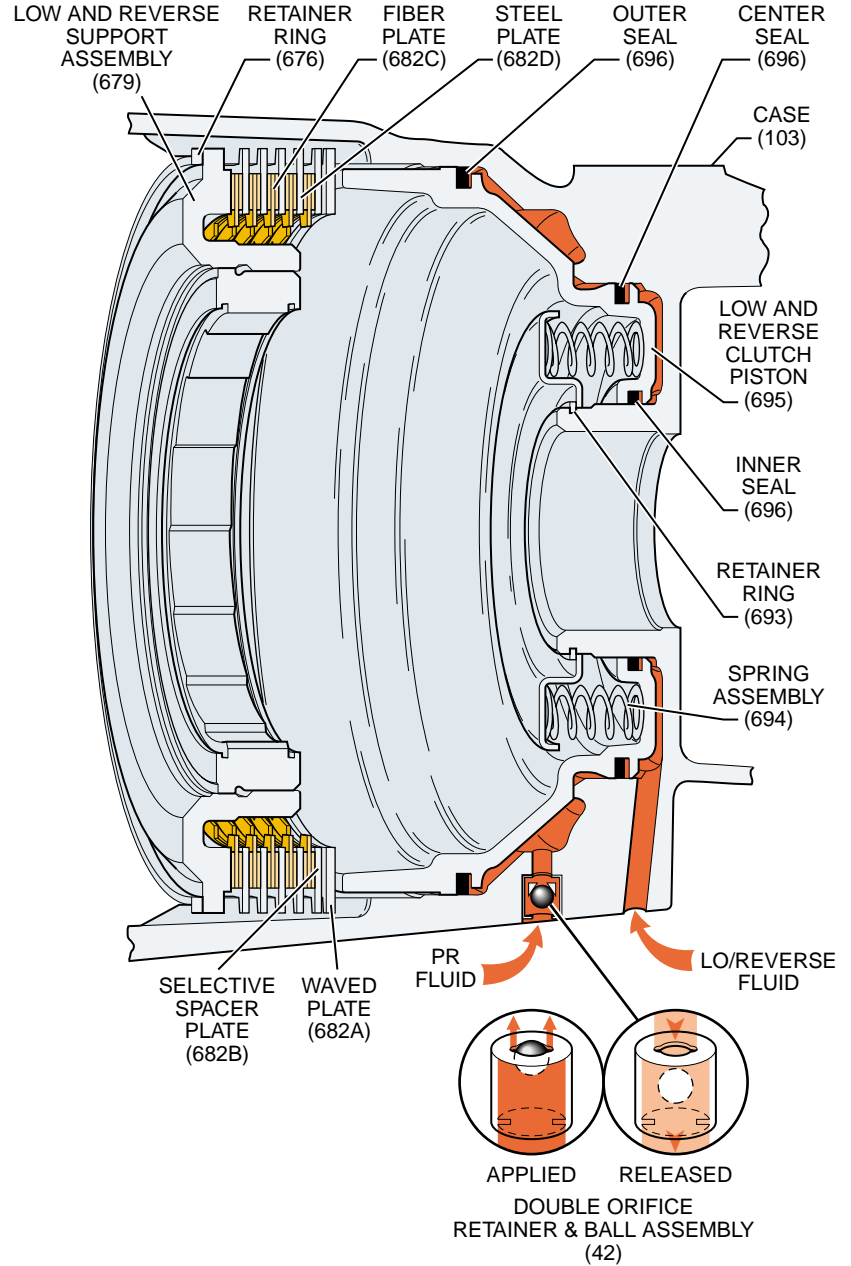

Worn low and reverse clutch plates or porosity in piston can cause no reverse/slips in reverse.

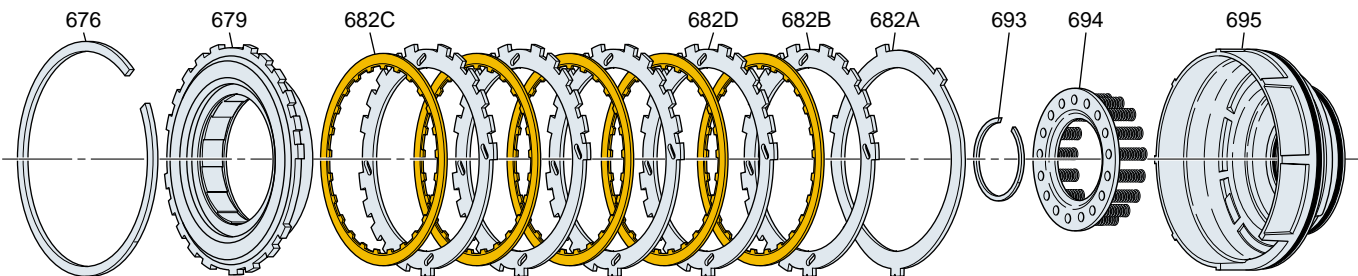
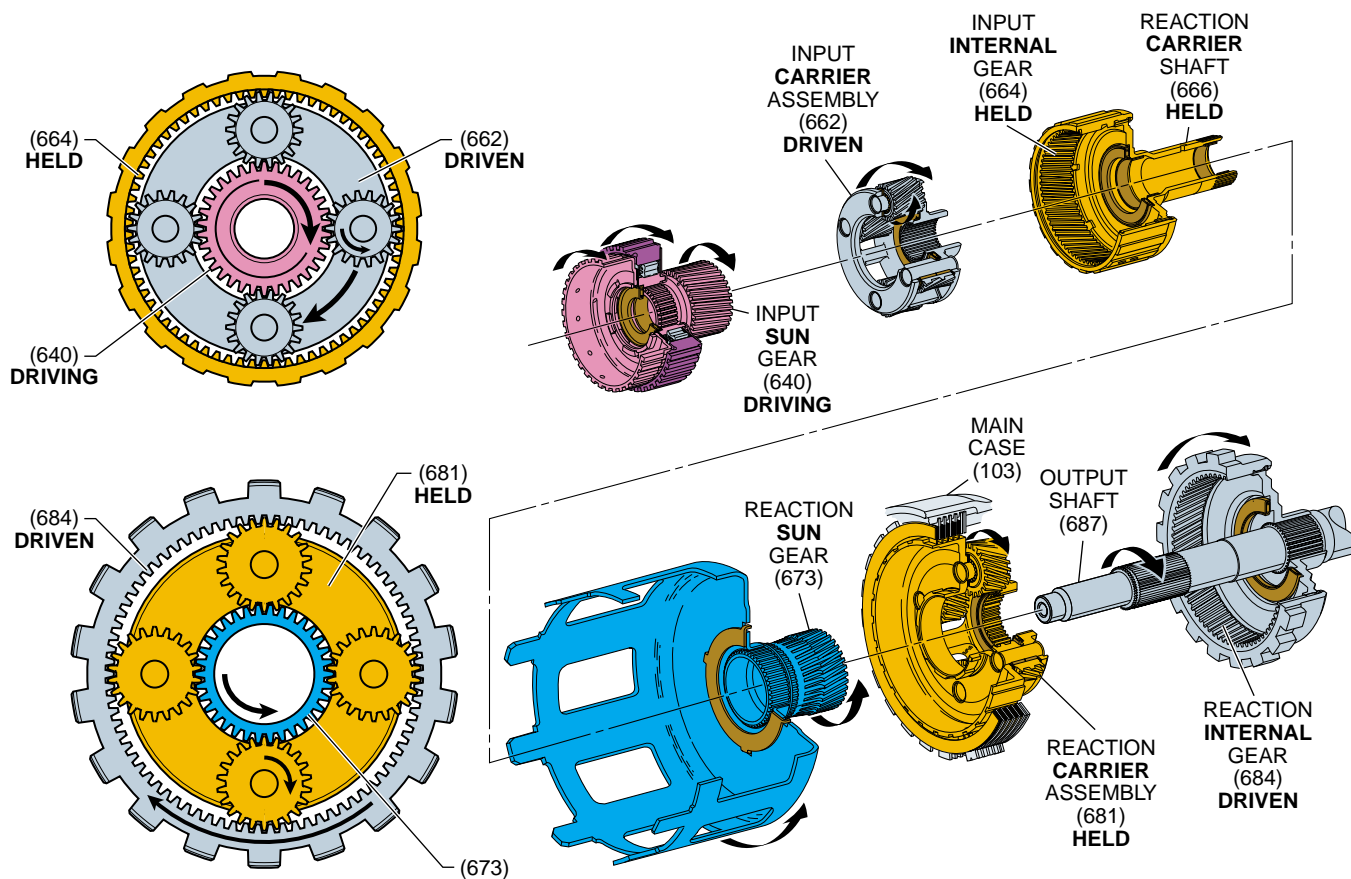

Figure 23

PLANETARY GEAR SETS

REDUCTION - FIRST GEAR



REDUCTION - SECOND GEAR

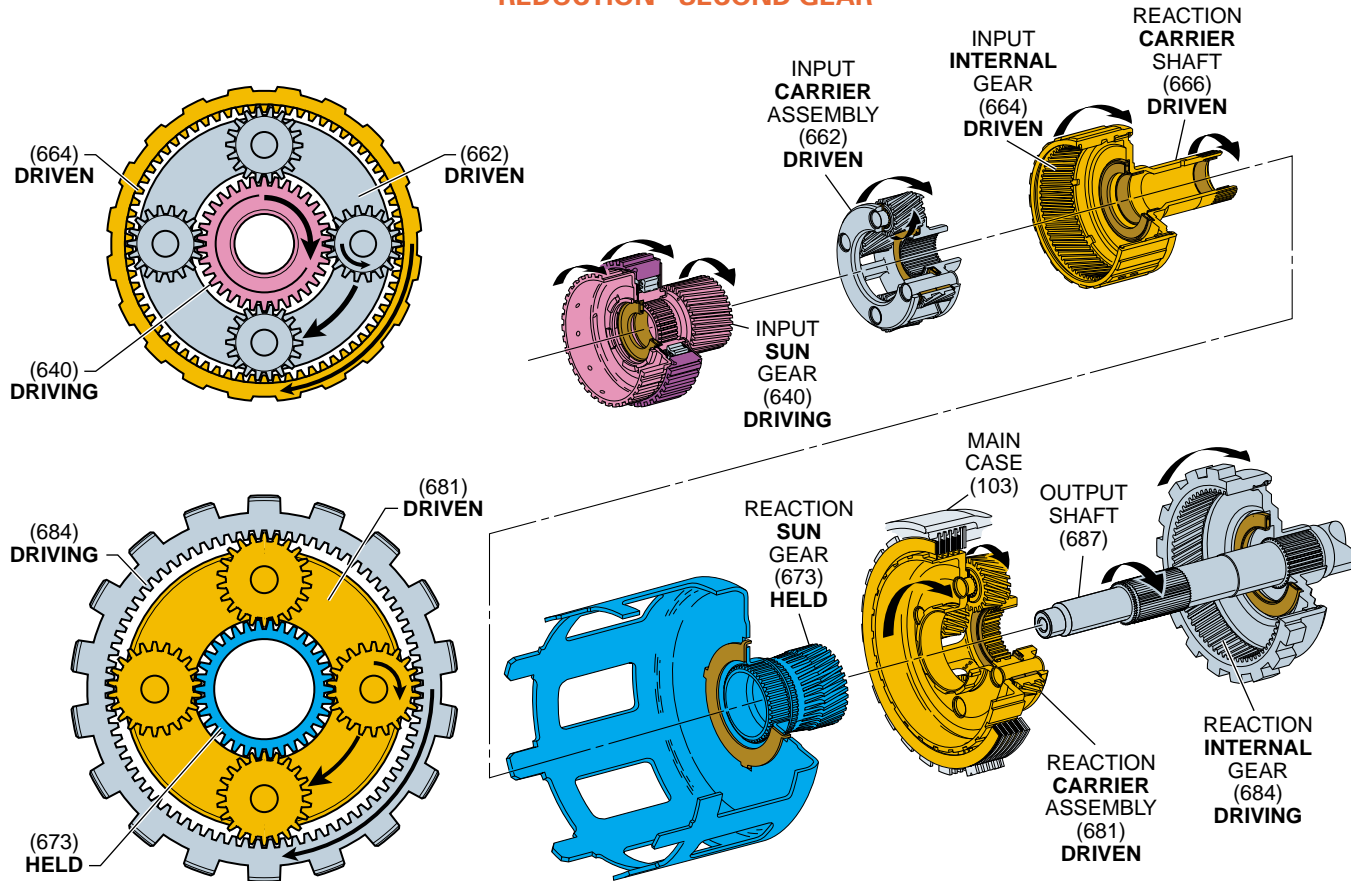

PLANETARY GEAR SETS

Planetary gear sets are used in the Hydra-matic 4L60-E transmission as the primary method of multiplying torque, or twisting force, of the engine (known as reduction). A planetary gear set is also used to reverse the direction of input torque, function as a coupling for direct drive, and provide an overdrive gear ratio.

Planetary gear sets are so named because of their physical arrangement. All planetary gear sets contain at least three main components:

- a sun gear at the center of the gear set,
- a carrier assembly with planetary pinion gears that rotate around the sun gear, and,
- an internal ring gear that encompasses the entire gear set.

This arrangement provides both strength and efficiency and also evenly distributes the energy forces flowing through the gear set. Another benefit of planetary gears is that gear clash, a common occurrence in manual transmissions, is eliminated because the gear teeth are always in mesh.

The Hydra-matic 4L60-E transmission consists of two planetary gear sets, the input and reaction gear sets. Figures 24 and 25 show both of these gear sets and their respective components. These figures also graphically explain how the planetary gear sets are used in combination to achieve each of the transmissions four forward drive gear ratios and Reverse.

Torque

When engine torque is transferred through a gear set the output torque from the gear set can either increase, decrease or remain the same. The output torque achieved depends on:

- which member of the gear set provides the input torque,
- which member of the gear set, if any, is held stationary, and,
- which member of the gear set provides the output torque.

If output torque is greater than input torque the gear set is operating in reduction (First, Second and Reverse gears). If output torque is less than input torque the gear set is operating in Overdrive (Fourth gear). When output torque equals input torque the gear set is operating in direct drive (Third gear) and all gear set components are rotating at the same speed.

Torque vs. Speed

One transmission operating condition directly affected by input and output torque is the relationship of torque with output speed. As the transmission shifts from First to Second to Third to Fourth gear, the overall output torque to the wheels decreases as the speed of the vehicle increases (with input speed and input torque held constant). Greater output torque is needed at low vehicle speed, First and Second gears, to provide the power for moving the vehicle from a standstill. However, once the vehicle is moving and the speed of the vehicle increases (Third and Fourth gears), less output torque is required to maintain that speed. This provides a more efficient operation of the powertrain.

REDUCTION

Increasing the output torque is known as operating in reduction because there is a decrease in the speed of the output member proportional to the increase in output torque. Therefore, with a constant input speed, the output torque increases when the transmission is in a lower gear, or higher gear ratio. In the Hydra-matic 4L60-E, planetary gear set reduction occurs when the transmission is operating in First, Second and Reverse gears.

In First gear, the input planetary gear set provides the gear reduction to obtain a starting gear ratio of 3.06:1. Engine torque is transferred to the input sun gear (640) while the input internal gear (664) is prevented from rotating by the low roller clutch (678). The input sun gear drives the input carrier pinions. As the pinions rotate counterclockwise on their pins, the pinion gears walk clockwise around the input internal gear. This action drives the input carrier assembly and output shaft (687) clockwise in the First gear reduction of 3.06:1.

PLANETARY GEAR SETS

In Second gear, both planetary gear sets, input and reaction, are used to achieve the Second gear reduction of 1.63:1. Power flow through the input gear set is similar to First gear to drive the output shaft. However, in Second gear the reaction sun gear (673) is held by applying the 2-4 band. The reaction internal gear support (685) is splined to the output shaft and drives the reaction carrier pinion gears clockwise. The pinion gears then walk clockwise around the stationary reaction sun gear, thereby driving the reaction carrier assembly (681) clockwise. The reaction carrier drives the reaction carrier shaft and input internal gear clockwise. The input internal gear then drives the input pinion gears in a second reduction to achieve the Second gear ratio.

DIRECT DRIVE

Direct drive in a planetary gear set is obtained when any two members of the gear set rotate in the same direction at the same speed. This action forces the third member of the gear set to rotate at the same speed. Therefore, in direct drive the output speed of the transmission is the same as the input speed from the converter turbine. Output speed will equal engine speed when the torque converter clutch is applied (see Torque Converter - page 12).

Direct drive is obtained when input torque to the input planetary gear set is transferred through both the input sun gear and the input internal gear. The input pinion gears are wedged between these components and forced to rotate at the same speed. The input carrier then drives the output shaft at the same speed as input torque to provide the direct drive 1:1 gear ratio.

OVERDRIVE

Operating the transmission in Overdrive allows the output speed of the transmission to be greater than the input speed from the engine. The vehicle can then maintain a given road speed with reduced engine speed for increased fuel economy.

Overdrive is achieved through the reaction planetary gear set and only occurs in Overdrive Range – Fourth Gear. The 2-4 band holds the reaction sun gear (673) stationary while input torque is provided through the reaction carrier assembly (681). As the carrier is driven clockwise, the reaction pinion gears rotate clockwise on their pins as they walk clockwise around the stationary sun gear. The pinion gears drive the reaction internal gear (684) and output shaft (687) clockwise in an overdrive ratio of .70:1.

REVERSE

In Reverse, the reaction planetary gear set is used to provide both the gear reduction and reversal of engine torque needed. Engine torque is provided through the reaction sun gear (673) which drives the reaction pinion gears counterclockwise. The reaction carrier assembly (681) is held stationary by the low roller clutch. This allows the reaction pinion gears to drive the reaction internal gear and output shaft counterclockwise in a reduction of 2.30:1.

PLANETARY GEAR SETS

REDUCTION - THIRD GEAR

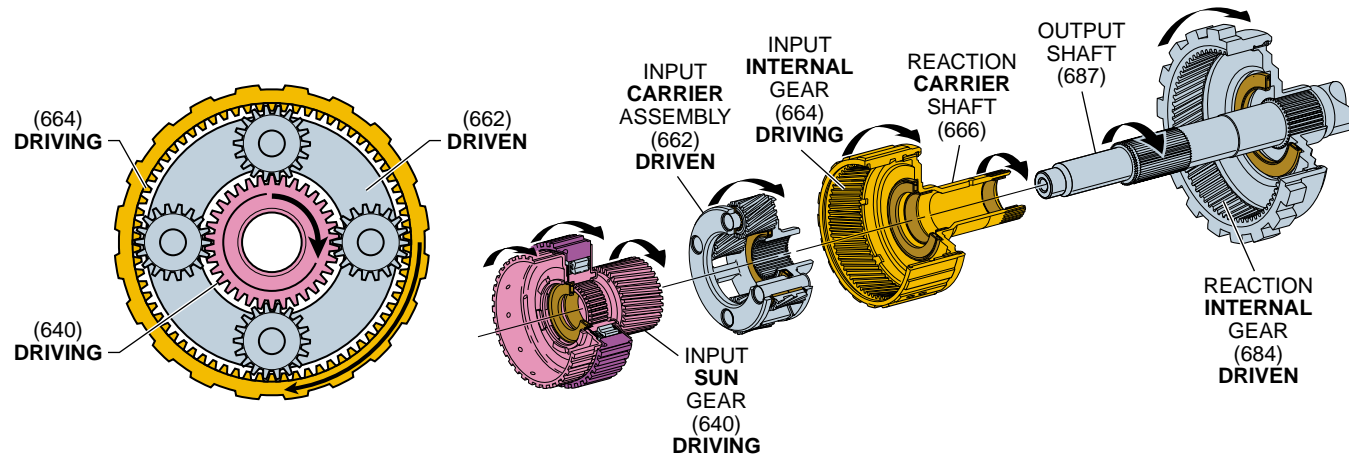

REDUCTION - FOURTH GEAR

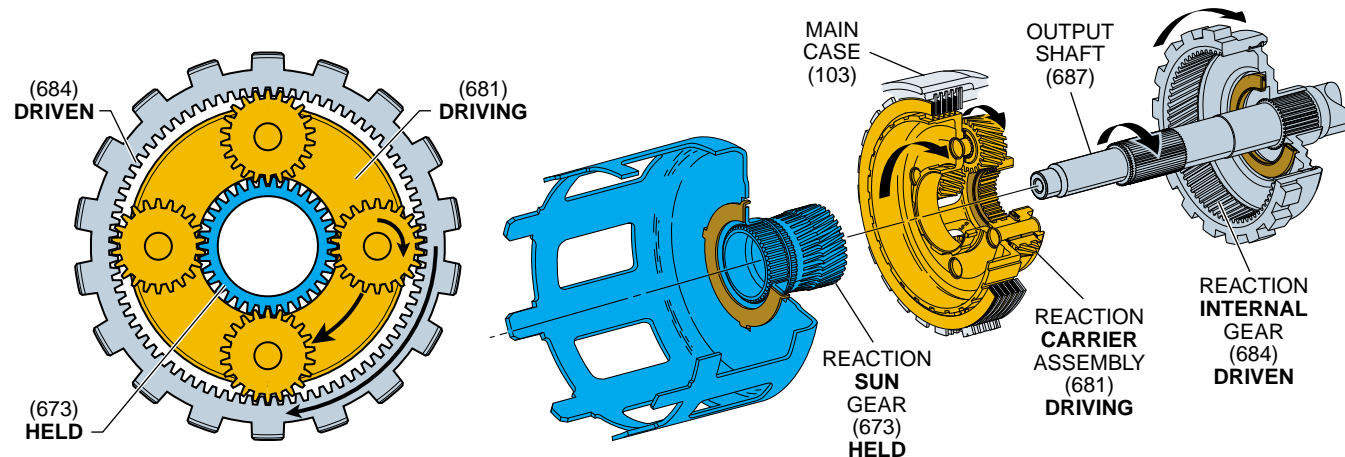

REDUCTION - REVERSE

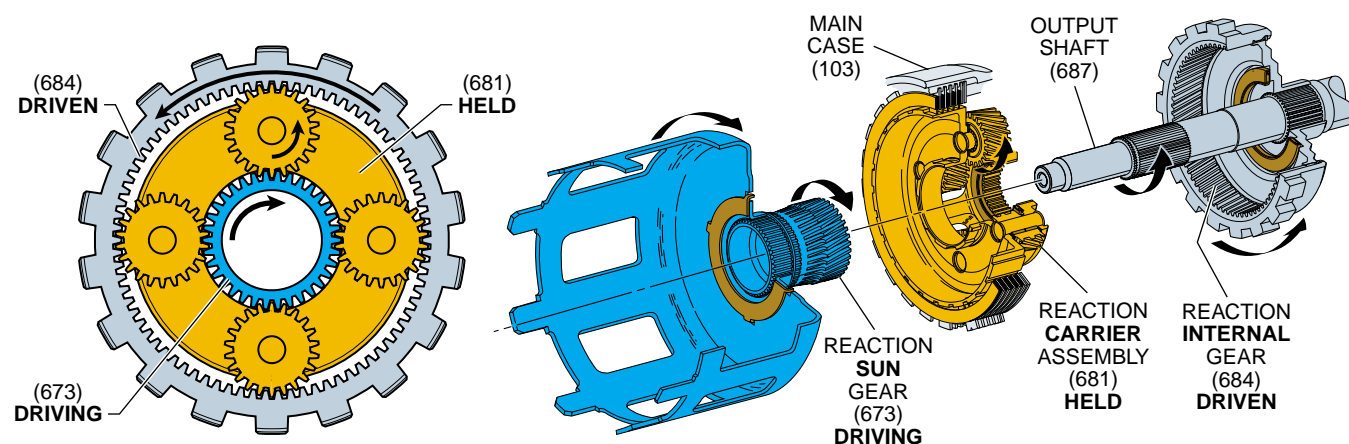

HYDRAULIC CONTROL COMPONENTS

The previous sections of this book were used to describe some of the mechanical component operations of the Hydra-matic 4L60-E. In the Hydraulic Control Components section a detailed description of the individual components used in the

hydraulic system will be presented. These hydraulic control components apply and release the clutch packs, band and accumulators to provide automatic shifting of the transmission.

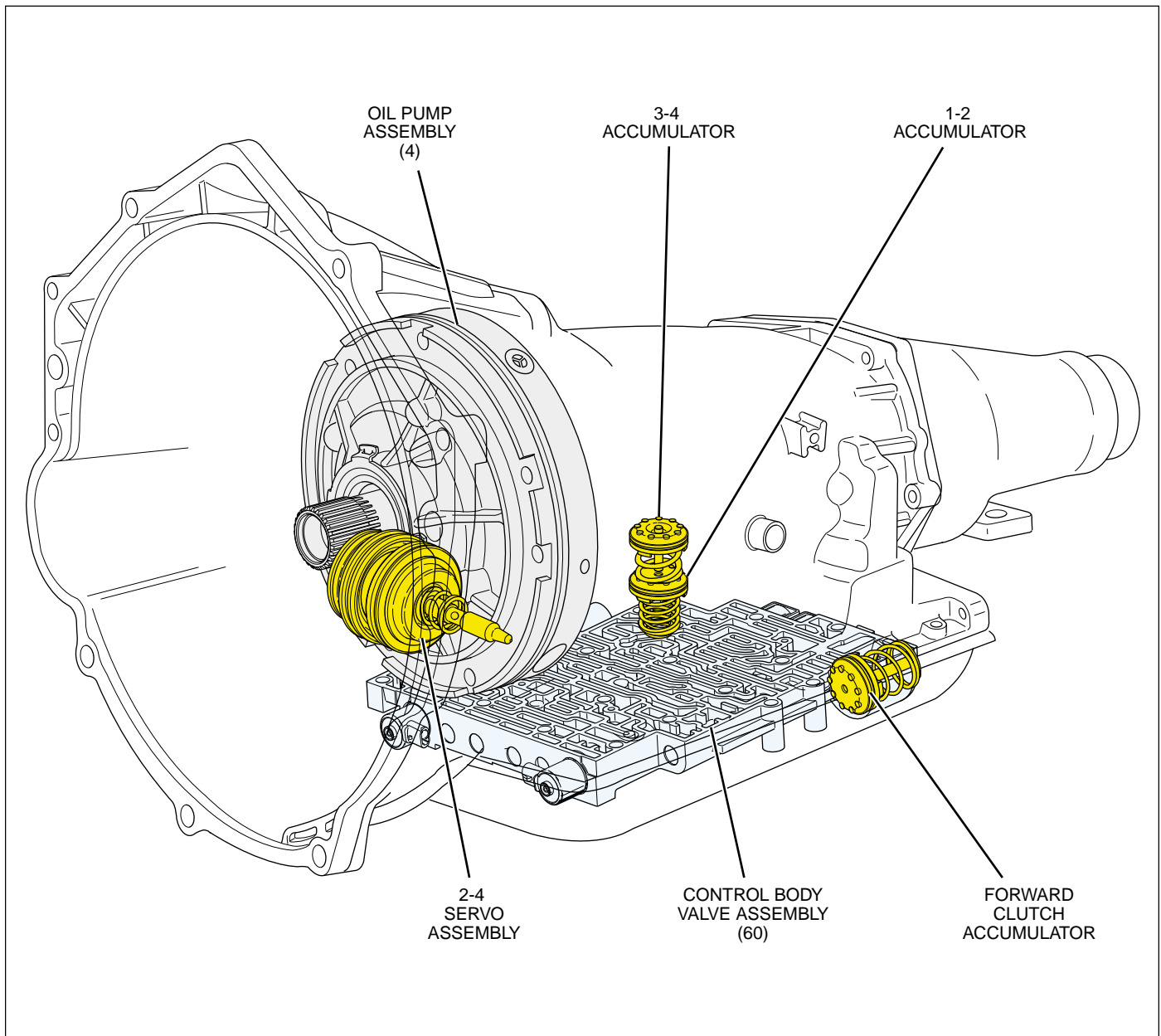
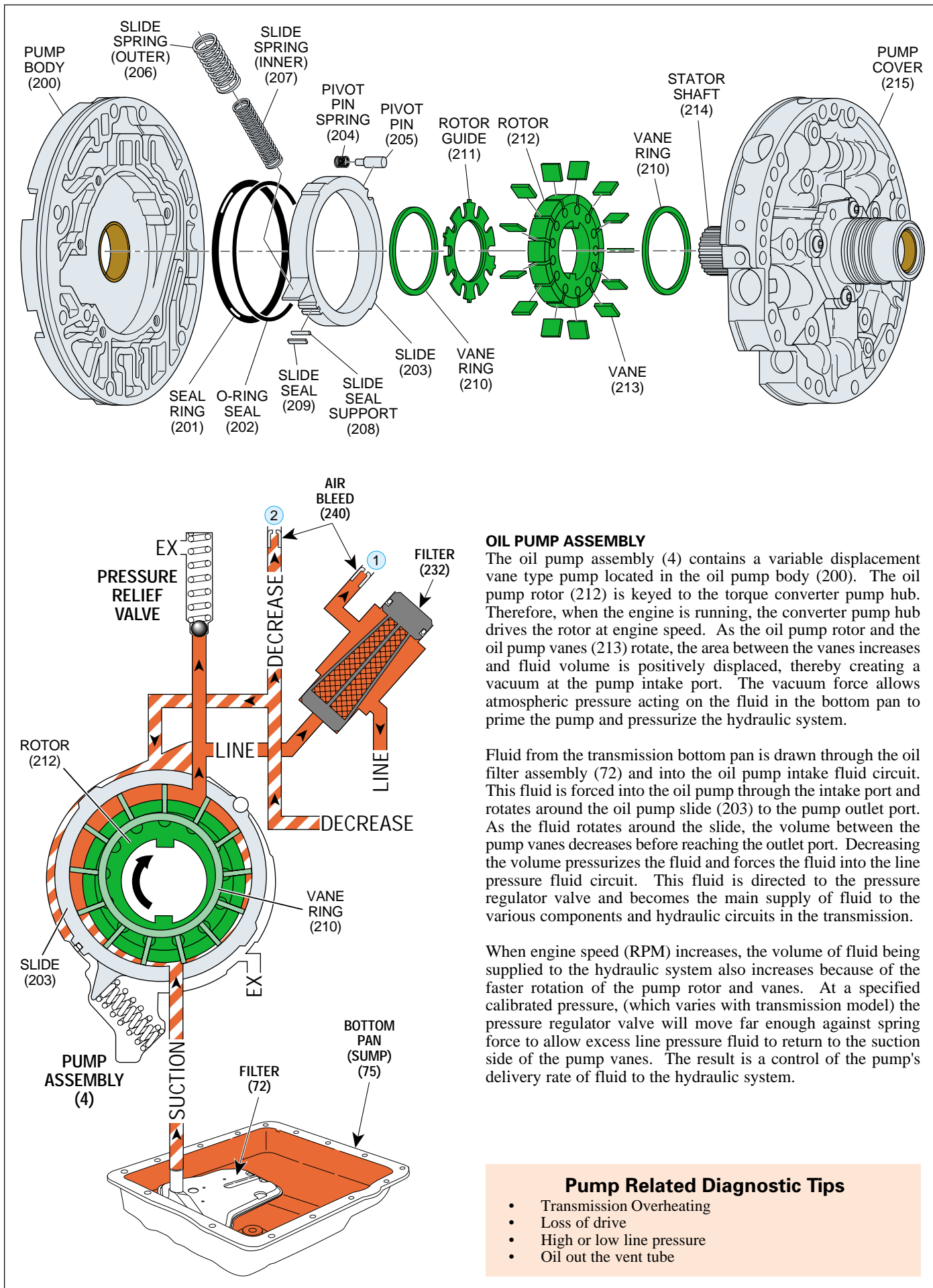

Figure 26

HYDRAULIC CONTROL COMPONENTS



OIL PUMP ASSEMBLY

The oil pump assembly (4) contains a variable displacement vane type pump located in the oil pump body (200). The oil pump rotor (212) is keyed to the torque converter pump hub. Therefore, when the engine is running, the converter pump hub drives the rotor at engine speed. As the oil pump rotor and the oil pump vanes (213) rotate, the area between the vanes increases and fluid volume is positively displaced, thereby creating a vacuum at the pump intake port. The vacuum force allows atmospheric pressure acting on the fluid in the bottom pan to prime the pump and pressurize the hydraulic system.

Fluid from the transmission bottom pan is drawn through the oil filter assembly (72) and into the oil pump intake fluid circuit. This fluid is forced into the oil pump through the intake port and rotates around the oil pump slide (203) to the pump outlet port. As the fluid rotates around the slide, the volume between the pump vanes decreases before reaching the outlet port. Decreasing the volume pressurizes the fluid and forces the fluid into the line pressure fluid circuit. This fluid is directed to the pressure regulator valve and becomes the main supply of fluid to the various components and hydraulic circuits in the transmission.

When engine speed (RPM) increases, the volume of fluid being supplied to the hydraulic system also increases because of the faster rotation of the pump rotor and vanes. At a specified calibrated pressure, (which varies with transmission model) the pressure regulator valve will move far enough against spring force to allow excess line pressure fluid to return to the suction side of the pump vanes. The result is a control of the pump's delivery rate of fluid to the hydraulic system.

Pump Related Diagnostic Tips

- Transmission Overheating
- Loss of drive
- High or low line pressure
- Oil out the vent tube

Figure 27

PRESSURE REGULATION

The main components that control line pressure are the pressure control solenoid and pressure regulator valve. The fluid pressure required to apply the clutches and band varies in relation to throttle position and engine torque. At the pressure regulator valve, line pressure is regulated in response to the following:

- torque signal fluid pressure routed from the pressure control solenoid (PCS) (this fluid pressure is proportional to engine torque - see page 42). Torque signal fluid pressure moves the boost valve (219) against the pressure regulator isolator spring (218) which acts against the pressure regulator valve.
- pressure regulator spring force.
- line pressure acting on the end of the pressure regulator valve.
- reverse input fluid pressure acting on the boost valve in Reverse.

The pressure regulator valve routes line pressure into both the converter feed and decrease fluid circuits. Converter feed fluid is routed to both the torque converter and cooler fluid circuits. Decrease fluid pressure moves the oil pump slide against the force of the pump slide springs (outer - 206, inner - 207). Decrease fluid pressure and the position of the pump slide constantly vary in relation to torque signal fluid pressure and engine torque as controlled by the pressure regulator valve.

Minimum Pressure Regulation

When engine torque is a minimum, the PCS regulates torque signal fluid pressure to a minimum. During these conditions, line pressure acting on the end of the pressure regulator valve

moves the valve against spring force and torque signal fluid pressure to a point where line pressure enters both the converter feed and decrease fluid circuits. Decrease fluid pressure moves the pump slide (203) against spring force and toward the center of the pump body, causing the slide to partially cover the pump intake port. This increases the concentricity between the pump slide and rotor which decreases the vacuum affect on the fluid, thereby decreasing line pressure.

Maximum Pressure Regulation

When engine torque is a maximum, the PCS regulates torque signal fluid pressure to a maximum. Maximum torque signal fluid pressure moves the boost valve against the isolator spring to increase the force on the pressure regulator valve. This moves the pressure regulator valve to block line pressure from entering the decrease fluid circuit. With lower decrease fluid pressure, pump slide spring force moves the slide against the side of the pump body. This decreases the concentricity between the slide and rotor which increases the vacuum affect on the fluid. In this position line pressure is a maximum. The output of the oil pump continuously varies between these minimum and maximum points depending on vehicle operating conditions.

Pressure Regulator Related Diagnostic Tips

A stuck or damaged pressure regulator valve could cause:

- High or low line pressure
- Slipping clutches or bands or harsh apply
- Transmission overheating
- Low or no cooler/lube flow

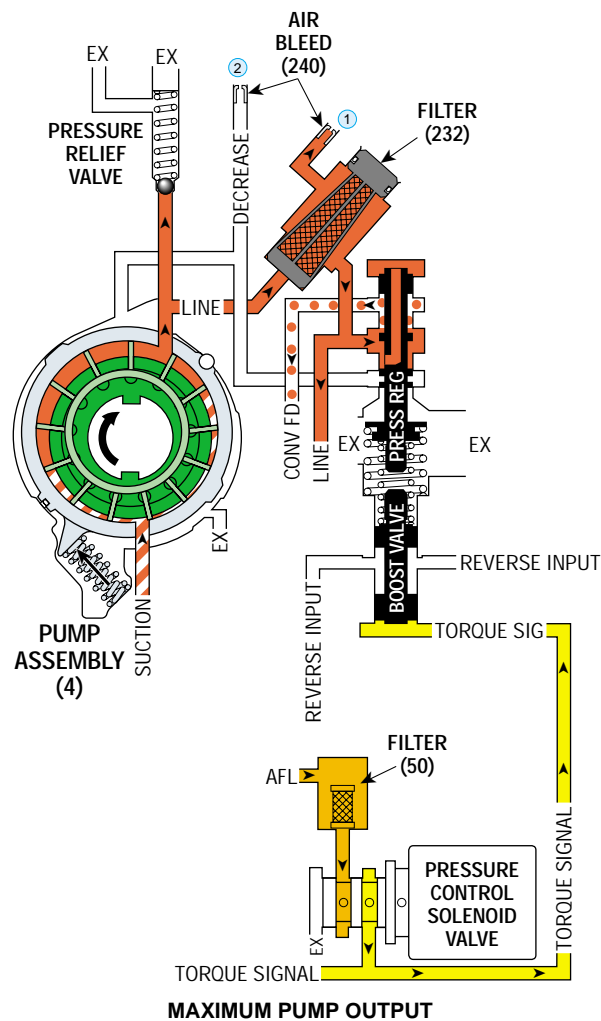
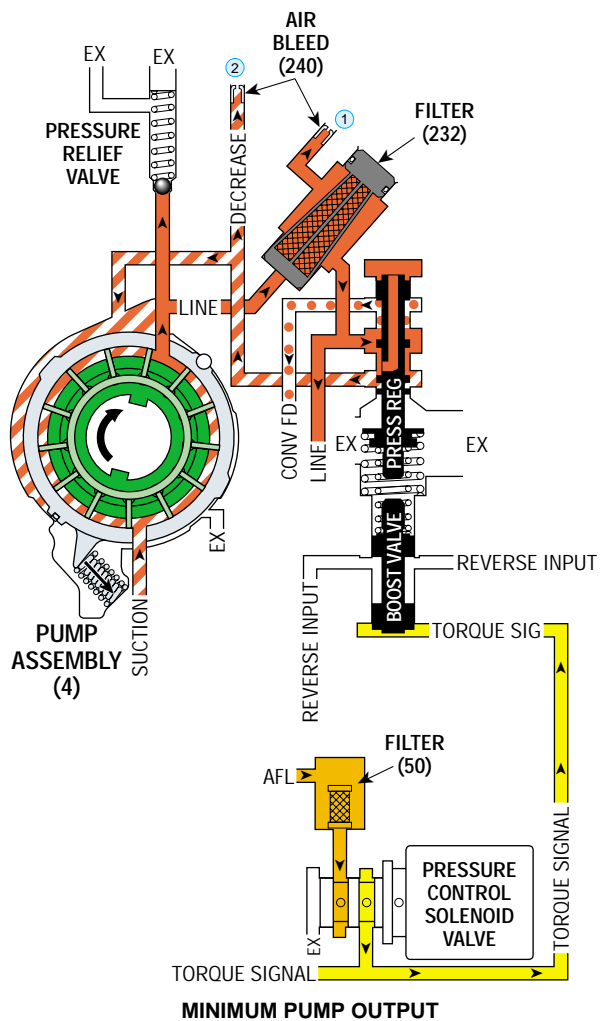

VALVES LOCATED IN THE OIL PUMP ASSEMBLY

Pressure Regulator Valve (216)

Regulates line pressure in relation to vehicle operating conditions (see page 28 on Pressure Regulation). The pressure regulator valve is biased by torque signal fluid pressure, pressure regulator spring (217) force, line pressure routed to the end of the valve, and reverse input fluid pressure acting on the boost valve in Reverse. Line pressure is routed through the valve and into both the converter feed and decrease fluid circuits.

- A stuck pressure regulator valve could cause high or low oil pressure.

Boost Valve (219)

Torque signal fluid pressure moves the boost valve against the isolator spring (218). The isolator spring then exerts the force from torque signal fluid pressure to the pressure regulator valve. Therefore, line pressure increases as throttle position and engine torque increase. Also, reverse input fluid pressure acting on the boost valve increases the operating range of line pressure when the transmission is in Reverse.

Pressure Relief Ball (228)

The pressure relief ball and spring (229) prevent line pressure from exceeding approximately 2240 to 2520 kPa (320 to 360 psi). Above this pressure, line fluid pressure moves the ball against spring force and exhausts until line pressure decreases sufficiently.

- A pressure relief ball not seated or damaged could cause high or low oil pressure.

Torque Converter Clutch Solenoid

The Powertrain Control Module (PCM) controls the TCC solenoid to apply and release the converter clutch. The TCC solenoid is a normally open, ON/OFF solenoid that, when energized (ON), initiates the converter clutch apply. Refer to the Electronic Component Section for a complete description of the TCC solenoid.

- No TCC apply could be caused by internal damage to the TCC solenoid.

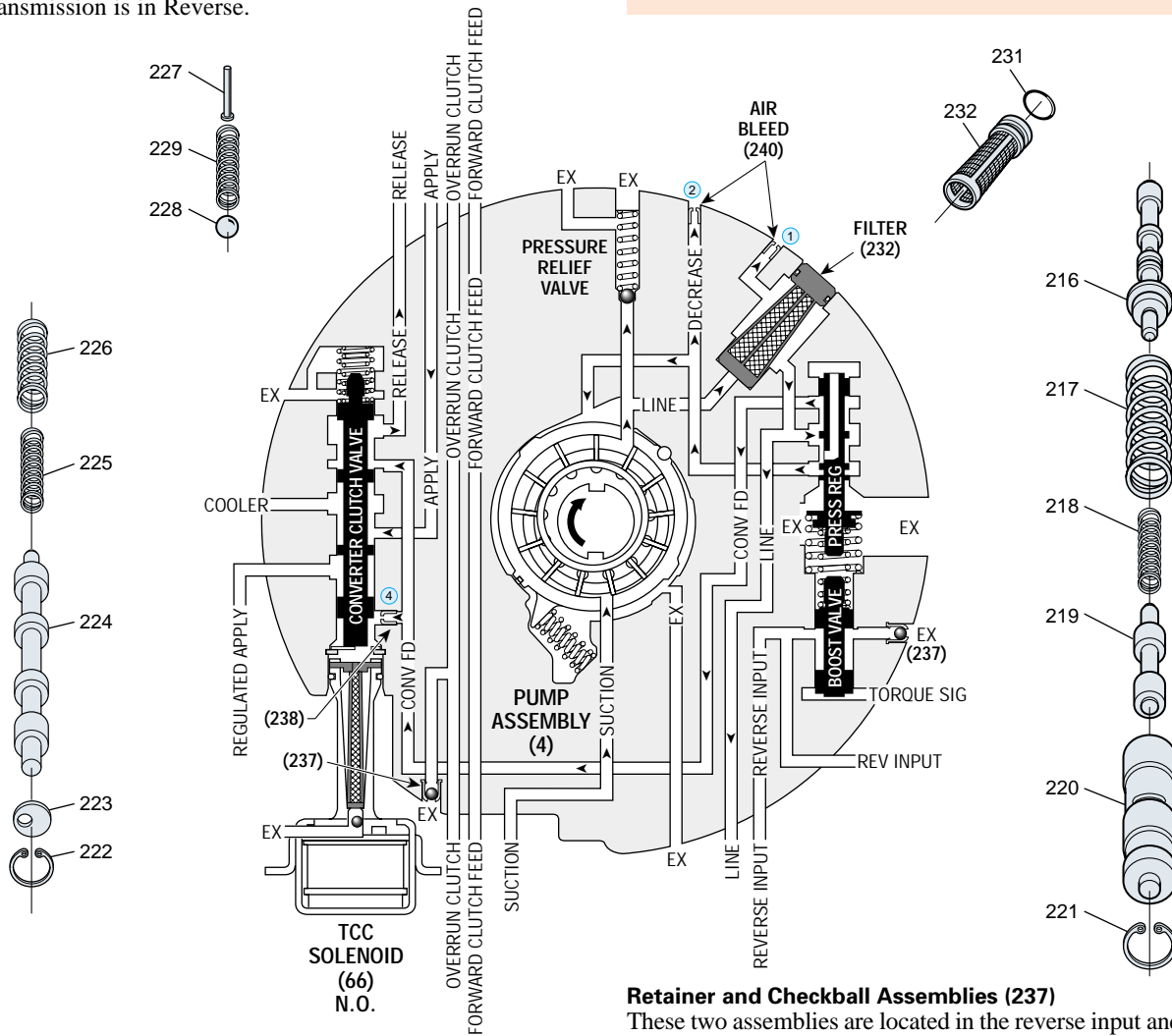

Torque Converter Clutch Apply Valve (224)

Controlled by the TCC solenoid state and converter clutch signal fluid pressure, it directs converter feed fluid pressure to either the release or apply side of the converter clutch. The TCC apply valve also directs fluid into the cooler fluid circuit. The valve is held in the release position (as shown) by spring force when the TCC solenoid is OFF. With the TCC solenoid ON, converter clutch signal fluid pressure increases and moves the valve into the apply position against spring force.

Retainer and Checkball Assemblies (237)

These two assemblies are located in the reverse input and overrun clutch fluid circuits. Their function is to allow air to escape from the fluid circuit when fluid pressure increases during clutch apply. Also, when the clutch releases the ball unseats and allows air into the circuit to displace the exhausting fluid.

Orifice Cup Plugs (238-240)

Various orifice cup plugs are located in the oil pump cover (215) to provide fluid flow control in the transmission's hydraulic system.

- Torque converter clutch shudder could be caused by a restricted or damaged orifice cup plug.

Figure 29

VALVES LOCATED IN THE CONTROL VALVE BODY

3-4 Shift Valve (385)

Biased by 1-2 signal fluid pressure from the 1-2 shift solenoid, spring force and D3 fluid pressure, the 3-4 shift valve controls the routing of 3-4 signal fluid. To obtain Fourth gear, 1-2 signal fluid pressure moves the valve against spring force and directs 3-4 signal fluid into the 4th signal fluid circuit. However, in Manual Third, D3 fluid assists spring force and holds the valve against 1-2 signal fluid pressure to prevent Fourth gear under any conditions. In the downshifted position, the 4th signal fluid circuit is open to an exhaust past the valve.

3-2 Downshift Valve (389)

The 3-2 downshift valve helps control the 2-4 band apply rate during a 3-2 downshift. During the downshift, 3-4 clutch fluid pressure holds the valve against spring force before exhausting. This allows 2nd fluid to quickly fill the 2nd clutch fluid circuit for a faster 2-4 band apply.

Reverse Abuse Valve (387)

The reverse abuse valve provides a faster apply of the reverse input clutch when throttle position is greater than idle. During these conditions, reverse fluid pressure increases and moves the valve against spring force. Reverse fluid can then quickly fill the reverse input fluid circuit. This bypasses the control of the reverse input orifice (#17) for a faster clutch apply.

3-2 Control Solenoid Valve (394)

The 3-2 control solenoid valve is a normally closed ON/OFF solenoid controlled by the PCM. The solenoid is used to route actuator feed limit (AFL) fluid into the 3-2 signal fluid circuit to control the position of the 3-2 control valve. The PCM controls the solenoid state during a 3-2 downshift according to vehicle speed.

3-2 Control Valve (391)

The 3-2 control valve regulates the exhaust of 3rd accumulator fluid into the 3-4 clutch fluid circuit during a 3-2 downshift. This regulation is controlled by 3-2 signal fluid pressure from the 3-2 control solenoid valve. At high vehicle speed, 3-2 signal fluid pressure moves the valve against spring force to block exhausting 3rd accumulator fluid from entering the 3-4 clutch fluid circuit. At low vehicle speed, 3-2 signal fluid pressure is OFF and the valve is held in the open position by spring force to allow exhausting 3rd accumulator fluid to enter the 3-4 clutch fluid circuit.

- A stuck 3-2 control valve could cause no 3-4 shift, slips or rough 3-4 shift.

Manual Valve (340)

The manual valve is supplied with line pressure from the pressure regulator valve and is mechanically linked to the gear selector lever. When a gear range is selected, the manual valve directs line pressure into various circuits by opening and closing fluid passages. The fluid circuits fed by the manual valve include Reverse, PR, D4, D3, D2 and lo.

- High or low oil pressure could be caused by a scored or damaged manual valve.

Pressure Control Solenoid Valve (377)

Controlled by the PCM through a duty cycle operation, the pressure control (PC) solenoid valve regulates AFL fluid pressure into the torque signal fluid circuit. Torque signal fluid pressure is regulated in response to engine torque and other vehicle operating conditions. Torque signal fluid pressure is routed to the boost valve to increase line pressure and to the accumulator valve to help control shift feel.

Actuator Feed Limit Valve (374)

The AFL valve directs line pressure into the AFL fluid circuit. Spring force acting on the valve limits AFL fluid pressure to a maximum of approximately 795 kPa (115 psi). When line pressure is above this value, orificed AFL fluid pressure moves the valve against spring force to block line pressure, thereby

providing the limiting action. AFL fluid is routed to the shift solenoids, the pressure control solenoid, the TCC PWM solenoid, the 3-2 control solenoid and the 2-3 shift valve train.

Torque Converter Clutch Pulse Width Modulated (TCC PWM) Solenoid Valve (396)

The TCC PWM solenoid valve is a normally closed, pulse width modulated (PWM) solenoid controlled by the PCM in relation to vehicle operating conditions. The TCC PWM solenoid valve regulates actuator feed limit fluid into the CC signal fluid circuit and is used to control the flow of line pressure through the regulated apply valve and provides a smooth engagement of the TCC.

- Stuck ON, exhaust plugged, would cause no TCC release in 2nd, 3rd or 4th gear.
- Stuck OFF, leaking o-ring, no voltage, would cause no TCC/slip or soft apply.

Regulated Apply Valve (380) and Isolator Valve (398)

The regulated apply valve and isolator valve are used to control the flow of line pressure into the regulated apply fluid circuit. Regulated apply fluid pressure is controlled by the action of CC signal fluid pressure on the isolator valve and orificed regulated apply fluid pressure on the regulated apply valve.

- A regulated apply valve stuck or assembled incorrectly could cause no TCC apply.

3-4 Relay Valve (384) and 4-3 Sequence Valve (383)

These valves are used mainly to control the 4-3 downshift timing. The valves direct various fluids into different fluid circuits depending on the gear range. Spring force acting on the 4-3 sequence valve tends to keep the valves in the downshifted position. In Fourth gear, 4th signal fluid pressure moves both valves against spring force and into the upshifted position (see Overdrive Range – 4-3 Downshift on page 64).

- A stuck 4-3 sequence valve could cause no overrun braking - manual 3-2-1.

Accumulator Valve (371)

The accumulator valve is biased by torque signal fluid pressure, spring force and orificed accumulator fluid pressure at the end of the valve. The valve regulates D4 fluid into accumulator fluid pressure in relation to engine torque, as determined by torque signal fluid pressure. Accumulator fluid pressure is used to control shift feel during the 1-2 and 3-4 shifts. During the 1-2 and 3-4 upshifts, the valve regulates the exhaust of accumulator fluid to help control shift feel.

- A stuck accumulator valve could cause no 3-4 shift, slips or rough 3-4 shift.

2-3 Shift Solenoid Valve (367)

Located at the end of the 2-3 shuttle valve, the 2-3 shift solenoid valve is a normally open, ON/OFF type solenoid controlled by the PCM. The solenoid is used to control 2-3 signal fluid pressure at the end of the 2-3 shuttle valve and the positioning of 2-3 shift valve train. When de-energized, the solenoid is open and 2-3 signal fluid exhausts through the solenoid. When energized, the solenoid is closed and blocks 2-3 signal fluid from exhausting, thereby creating 2-3 signal fluid pressure at the end of the 2-3 shuttle valve.

2-3 Shift Valve (368) and 2-3 Shuttle Valve (369)

The 2-3 shift valve train responds to AFL fluid pressure acting on the 2-3 shift valve and 2-3 signal fluid pressure from the 2-3 shift solenoid valve at the 2-3 shuttle valve. Also, in Manual Second and Manual First gear ranges, D2 fluid pressure is routed between the two valves. D2 fluid pressure keeps the 2-3 shift valve in the downshifted position to prevent the transmission from upshifting above Second gear regardless of shift solenoid states. The valve train controls the routing and

HYDRAULIC CONTROL COMPONENTS

VALVES LOCATED IN THE CONTROL VALVE BODY

exhausting of various fluids to obtain the appropriate gear range as determined by the PCM or gear selector lever.

- A stuck 2-3 shift valve could cause no reverse or slips in reverse.

1-2 Shift Solenoid Valve (367)

Located at the end of the 1-2 shift valve, the 1-2 shift solenoid valve is a normally open, ON/OFF type solenoid controlled by the PCM. The solenoid is used to control 1-2 signal fluid pressure and the positioning of both the 1-2 shift valve and the 3-4 shift valve. When de-energized (OFF), the solenoid is open and 1-2 signal fluid exhausts through the solenoid. When energized (ON), the solenoid is closed and blocks 1-2 signal fluid from exhausting, thereby creating 1-2 signal fluid pressure at the 1-2 and 3-4 shift valves.

1-2 Shift Valve (366)

The 1-2 shift valve is biased by 1-2 signal fluid pressure, spring force and D432 fluid pressure. The valve position depends on the shift solenoid states. The 1-2 shift solenoid valve controls 1-2 signal fluid pressure and the 2-3 shift solenoid valve controls the 2-3 shuttle valve position and D432 fluid pressure. The 1-2 shift valve directs D4 fluid into the 2nd fluid circuit to upshift the transmission to Second gear. The valve also routes lo fluid into the lo/1st fluid circuit in Manual First – First Gear. The exhaust past the valve is an annulus exhaust in which exhausting fluid, either 2nd fluid or lo/1st fluid, flows around the valve land and through the valve body.

- A sticking 1-2 shift valve could cause no upshift in 1st gear.

Forward Abuse Valve (357)

The forward abuse valve provides a faster apply of the forward clutch when throttle position is greater than idle. During these conditions, D4 fluid pressure increases and moves the valve against spring force. D4 fluid can then quickly fill the forward clutch feed fluid circuit. This bypasses the control of the forward clutch accumulator orifice (#22) for a faster clutch apply.

Lo Overrun Valve (361)

In Reverse, PR fluid moves the valve against spring force and fills the lo/reverse fluid circuit. In Manual First, the lo overrun valve regulates lo/1st fluid pressure into the lo/reverse fluid circuit. This regulation is biased by spring force and orificed lo/reverse fluid pressure acting on the valve.

- A stuck lo overrun valve could cause no reverse or slips in reverse.

Forward Clutch Accumulator

Forward clutch accumulator spring force absorbs the initial increase in forward clutch feed fluid pressure to cushion the forward clutch apply. Refer to page 32 for a complete description of accumulator function.

Note: Refer to the 'Power Flow' and 'Complete Hydraulic Circuit' sections for a detailed explanation of each components operation in a specific gear range. Also, refer to the 'Electronic Components' section for a detailed description of each electronic component.

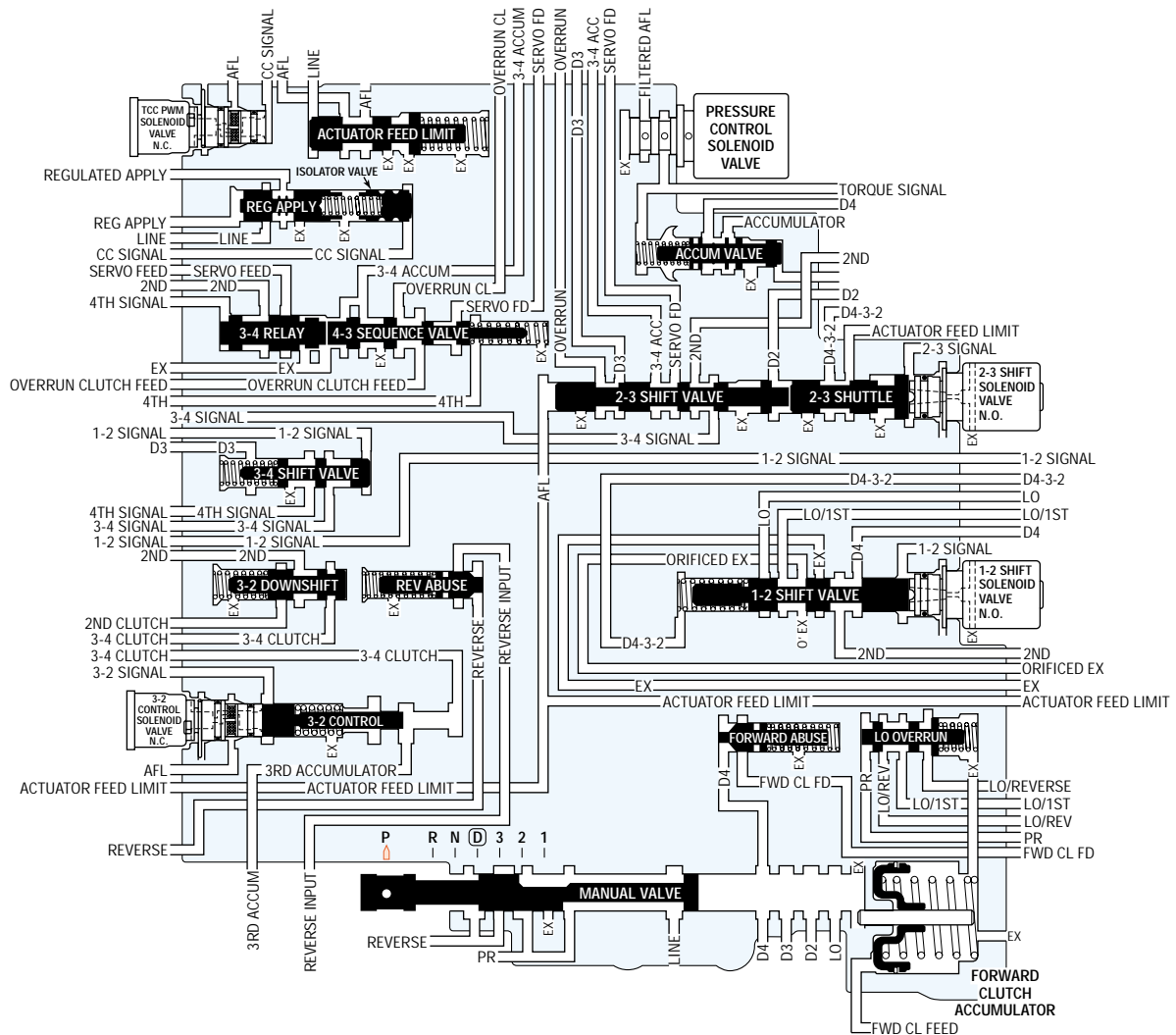
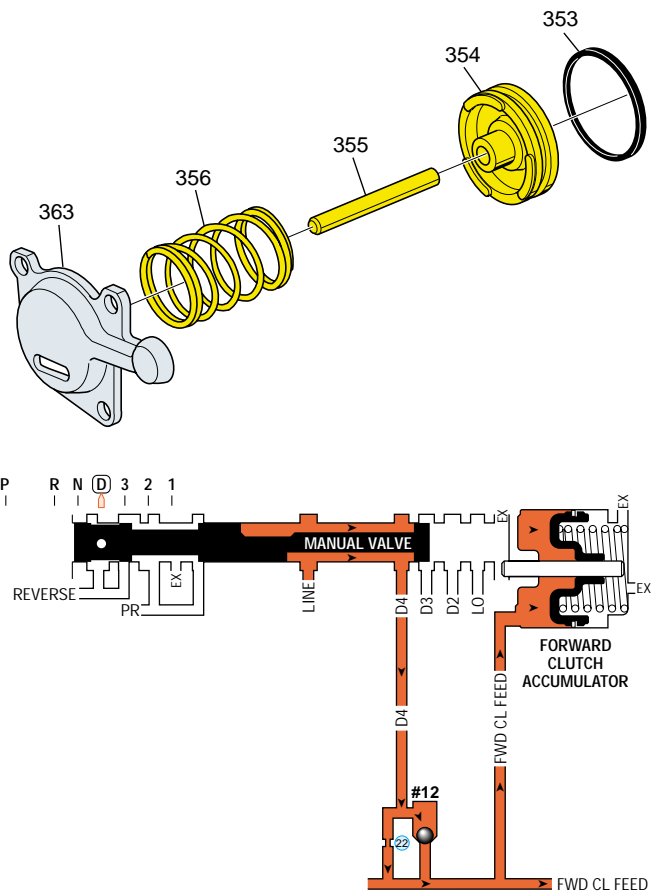

Figure 30



EXAMPLE: FORWARD CLUTCH ACCUMULATION

ACCUMULATORS

An accumulator is a spring loaded device that absorbs a certain amount of apply fluid pressure to cushion the apply of a clutch or band. Apply fluid pressure directed to an accumulator piston opposes a spring force, and an accumulator fluid pressure (except in the forward clutch accumulator), to act like a shock absorber.

In the Hydra-matic 4L60-E transmission, accumulators are used to control shift feel during the apply of the forward clutch, 2-4 band (in both Second and Fourth gears) and 3-4 clutch. During the apply of a clutch or band, apply fluid pressure builds up rapidly when the friction element begins to hold. As the fluid pressure increases, it also moves the accumulator piston against spring force and accumulator fluid pressure. Without an accumulator in the apply fluid circuit, the rapid buildup of fluid pressure would cause the clutch or band to apply very quickly and possibly create a harsh shift. However, accumulator spring force and accumulator fluid pressure absorb some of the initial apply fluid pressure to allow a more gradual apply of the clutch or band.

FORWARD CLUTCH ACCUMULATOR

The forward clutch accumulator is located in the valve body (350) and helps control the garage shift feel into a forward drive range from Park, Reverse or Neutral. Forward clutch feed fluid pressure that applies the forward clutch is also routed to the forward clutch accumulator piston (354). Forward clutch feed fluid pressure moves the accumulator piston against spring force (356) as the clutch begins to apply. This action absorbs some of the initial increase of clutch apply fluid pressure to cushion the forward clutch apply.

Slips in 1st gear could be caused by:

- A missing, cut or damaged forward clutch accumulator piston seal.
- A piston out of its bore.
- Porosity in the piston or valve body.
- A stuck abuse valve.

1-2 and 3-4 ACCUMULATOR ASSEMBLIES

Accumulator Valve Function

The 1-2 and 3-4 accumulator assemblies help cushion the 2-4 band apply rate. These assemblies use an accumulator fluid pressure to assist spring force. Accumulator fluid pressure is regulated by the accumulator valve (371) in relation to torque signal fluid pressure. The pressure control (PC) solenoid is controlled by the PCM and regulates torque signal fluid pressure in relation to engine torque, throttle position and other vehicle operating conditions.

When engine torque is a maximum, a greater apply pressure is required to prevent the band from slipping during apply and hold the band against the reverse input housing. When engine torque is a minimum, the band requires less apply force and a slower apply rate. The regulating action of the accumulator valve compensates for these various operating conditions by increasing accumulator fluid pressure as engine torque and torque signal fluid pressure increase.

1-2 ACCUMULATOR ASSEMBLY

The 1-2 accumulator assembly is used to control the apply feel of the 2-4 band in Second gear. The assembly is located between the spacer plate (48) and 1-2 accumulator cover (57) and consists of a piston (56), spring (54) and apply pin.

A stuck 1-2 accumulator piston could cause slipping or a rough 1-2 shift.

Upshift Control

During a 1-2 upshift (as shown in Example), 2nd clutch fluid is routed to both the servo assembly and the 1-2 accumulator assembly. The rapid buildup of fluid pressure in the 2nd clutch fluid circuit strokes the accumulator piston against spring force

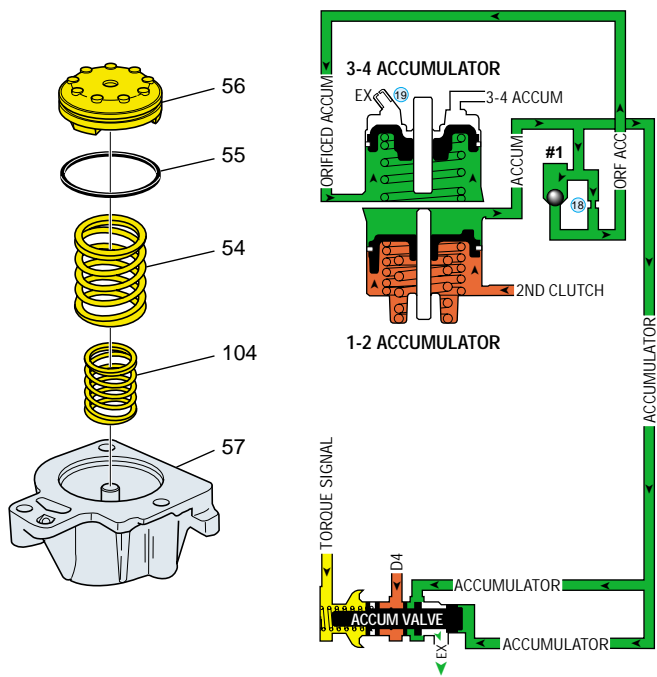

EXAMPLE: 1-2 UPSHIFT

HYDRAULIC CONTROL COMPONENTS

and accumulator fluid pressure. This action absorbs some of the initial buildup of 2nd clutch fluid pressure and provides a time delay to cushion the 2-4 band apply.

As 2nd clutch fluid pressure moves the accumulator piston, some accumulator fluid is forced out of the 1-2 accumulator assembly. This fluid pressure is routed back to the accumulator valve. The increase in accumulator fluid pressure acting on the end of the accumulator valve moves the valve against spring force and torque signal fluid pressure. This blocks D4 fluid and regulates the exhaust of the excess accumulator fluid pressure past the accumulator valve and through an exhaust port. This regulation provides additional control for the accumulation of 2nd clutch fluid and apply of the 2-4 band.

Downshift Control

2nd clutch fluid pressure exhausts from the 1-2 accumulator assembly during a 2-1 downshift. As spring force and accumulator fluid pressure move the 1-2 accumulator piston against exhausting 2nd clutch fluid, the accumulator valve regulates more D4 fluid into the accumulator fluid circuit. This regulation controls the rate at which accumulator fluid fills the 1-2 accumulator and the rate at which 2nd clutch fluid exhausts from the accumulator.

3-4 ACCUMULATOR ASSEMBLY

The 3-4 accumulator assembly is located in the transmission case and consists of a piston (44), piston spring (46) and piston pin (43). The 3-4 accumulator assembly is the primary device for controlling the apply feel of the 2-4 band in Fourth gear.

The 3-4 accumulator assembly functions similar to the 1-2 accumulator assembly. During a 3-4 upshift the 3-4 accumulator absorbs the initial increase of 3-4 accumulator fluid pressure to control the 2-4 band apply.

No 3-4 shift, slips or rough 3-4 shift could be caused by:

- Porosity in 3-4 accumulator piston or bore.
- 3-4 accumulator piston seal or seal grooves damaged.

3-4 Accumulator Checkball (#1)

During a 4-3 downshift, accumulator fluid seats the #1 checkball and is orificed into the orificed accumulator fluid circuit. This orifice (#18) controls the increase of orificed accumulator fluid pressure and the movement of the 3-4 accumulator piston against exhausting 3-4 accumulator fluid.

2-3 UPSHIFT ACCUMULATION

During a 2-3 upshift, the 2-4 band releases as the 3-4 clutch applies. To accomplish this, 3-4 clutch fluid that applies the 3-4 clutch is also routed into the 3rd accumulator fluid circuit. 3rd accumulator fluid pressure is used to release the band while 3-4 clutch fluid pressure is used to apply the 3-4 clutch. 3rd accumulator fluid pressure is routed to the 2-4 servo and moves the 2nd apply piston against spring force and 2nd clutch fluid pressure to release the band. This action functions as an accumulator for the 3-4 clutch by absorbing some of the initial increase in 3-4 clutch fluid pressure.

- A 2nd servo apply piston seal missing, cut or damaged could cause a slipping or rough 1-2 shift.
- A 4th servo piston installed backwards could cause slips in 1st gear.
- No 3-4 shift, slips or rough 3-4 shift could be caused by damaged piston seal grooves.
- A 2-4 servo assembly apply pin that is too short or too long could cause no 2-3 shift or 2-3 shift slips, rough or hunting.

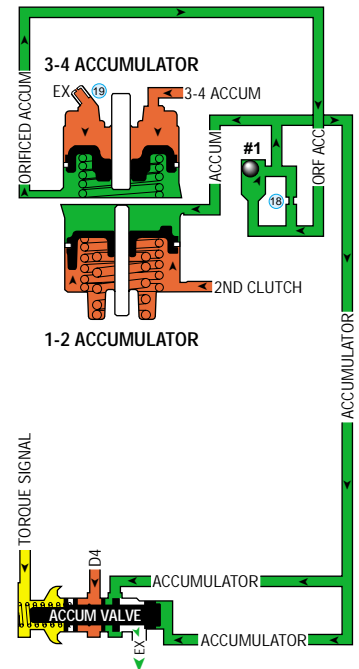
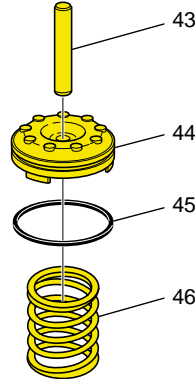

EXAMPLE: 3-4 UPSHIFT

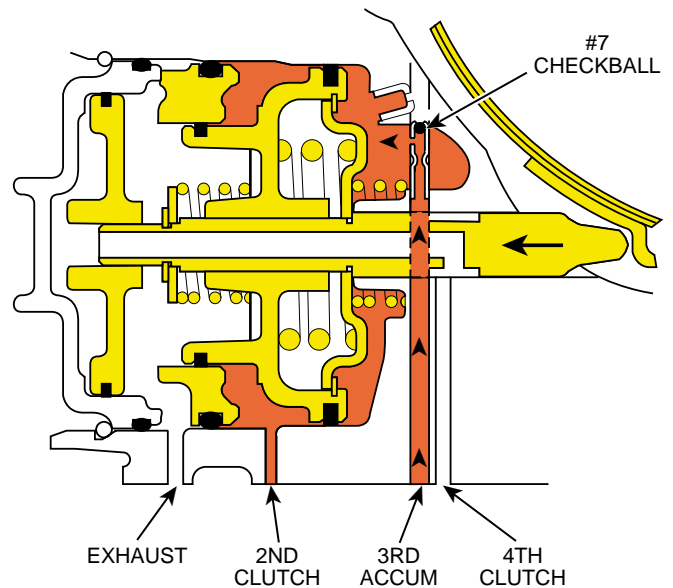

2-4 SERVO ASSEMBLY

BALL CHECK VALVE LOCATION AND FUNCTION

#1 3-4 ACCUMULATOR

Located in the transmission case, the 3-4 accumulator ball check valve helps control the flow of accumulator fluid to the 3-4 accumulator. When the ball is seated, accumulator fluid is forced through the #18 orifice. This action helps control the 2-4 band release during a 4-3 downshift.

#2 3RD ACCUMULATOR

Located in the valve body, the 3rd accumulator ball check valve directs exhausting 3rd accumulator fluid through orifice #12 and to the 3-2 control valve. This helps control the 2-4 band apply during a 3-2 downshift. During a 3-4 upshift, 3-4 clutch fluid unseats the ball for a quick feed into the 3rd accumulator fluid circuit.

Note: Some models do not include orifice #12 in the spacer plate. For these models, all exhausting 3rd accumulator fluid is routed to the 3-2 control valve.

#3 REVERSE INPUT

Located in the valve body, the reverse input ball check valve controls the reverse input clutch apply when engine speed is at idle. During these conditions, all reverse fluid feeding the reverse input fluid circuit is routed to the ball, seats the ball, and is forced through orifice #17. This slows the flow of reverse fluid to cushion the reverse input clutch apply. When the reverse input clutch releases, exhausting reverse input fluid unseats the ball for a quick exhaust of fluid.

#4 3-4 CLUTCH EXHAUST

Located in the valve body, this ball check valve helps control the 3-2 downshift. Exhausting 3-4 clutch and 3rd accumulator fluids seat the ball and are forced through orifice #13. This helps control the 3-4 clutch release rate and 2-4 band apply. During a 3-4 upshift, 3-4 signal fluid unseats the ball for a quick feed into the 3-4 clutch fluid circuit.

#5 OVERRUN CLUTCH FEED

Located in the valve body, it routes either overrun fluid or D2 fluid into the overrun clutch feed fluid circuit while blocking the other fluid circuit. Overrun clutch feed fluid feeds the overrun clutch fluid circuit in the Manual gear ranges to apply the overrun clutch.

#6 OVERRUN CLUTCH CONTROL

Located in the valve body, the #6 ball check valve helps control the overrun clutch apply rate. Overrun clutch feed fluid pressure seats the ball and is forced through orifice #20. This orifice slows the flow of overrun fluid to cushion the overrun clutch apply. When the overrun clutch releases, overrun clutch feed fluid unseats the ball for a quick exhaust.

#7 3RD ACCUMULATOR EXHAUST

Located in the transmission case, it unseats when 3rd accumulator fluid exhausts from the 2-4 servo to prevent residual fluid pressure from accumulating. Also, before 3rd accumulator fluid pressure seats the ball during a 2-3 upshift, any air in the circuit exhausts past the ball.

#8 1-2 UPSHIFT

Located in the valve body, the 1-2 upshift ball check valve helps control the 2-4 band apply during a 1-2 upshift. During the upshift, 2nd fluid pressure seats the ball and is forced through the #16 orifice. This orifice slows the flow of 2nd fluid to help cushion the band apply. When the band releases during a 2-1 downshift, exhausting 2nd clutch fluid unseats, and exhausts past, the 1-2 upshift ball check valve.

#9 TCC APPLY

Located in the end of the turbine shaft, the #9 ball check valve is a retainer and ball assembly that helps control the converter clutch apply feel. As the converter clutch applies, exhausting release fluid seats, and is orificed around the ball check valve. This action slows the exhaust of release fluid to control the converter clutch apply feel. When the converter clutch is released, release fluid pressure unseats the ball check valve and flows freely past the ball to keep the pressure plate disconnected from the converter cover.

#10 LO/REVERSE CLUTCH APPLY

Located in the transmission case, the #10 ball check valve is a retainer and ball assembly that helps control the lo and reverse clutch apply feel. During the clutch apply, PR fluid pressure seats, and is orificed around the ball check valve. This orifice slows the increase of PR fluid pressure at the clutch piston to cushion the apply feel. When the clutch releases, exhausting PR fluid unseats the ball check valve for a quick exhaust.

#12 FORWARD CLUTCH ACCUMULATOR

Located in the valve body, it helps control the forward clutch apply when engine speed is at idle. During these conditions, all D4 feeding the forward clutch feed fluid circuit is routed to the ball, seats the ball, and is forced through orifice #22. This slows the increase of forward clutch feed fluid pressure to cushion the forward clutch apply. When the forward clutch releases, exhausting forward clutch feed fluid unseats the ball for a quick exhaust of fluid.

Ball Check Valves Related Diagnostic Tips

Understanding the design principle of each ball check valve will help in the diagnosis of hydraulic related conditions. For example:

- a harsh shift complaint could be a stuck or missing ball check valve.
- no overrun braking in manual 3-2-1 could be a mispositioned checkball.
- high or low oil pressure could be caused by an omitted or misassembled ball check valve.

HYDRAULIC CONTROL COMPONENTS

BALL CHECK VALVE LOCATION AND FUNCTION

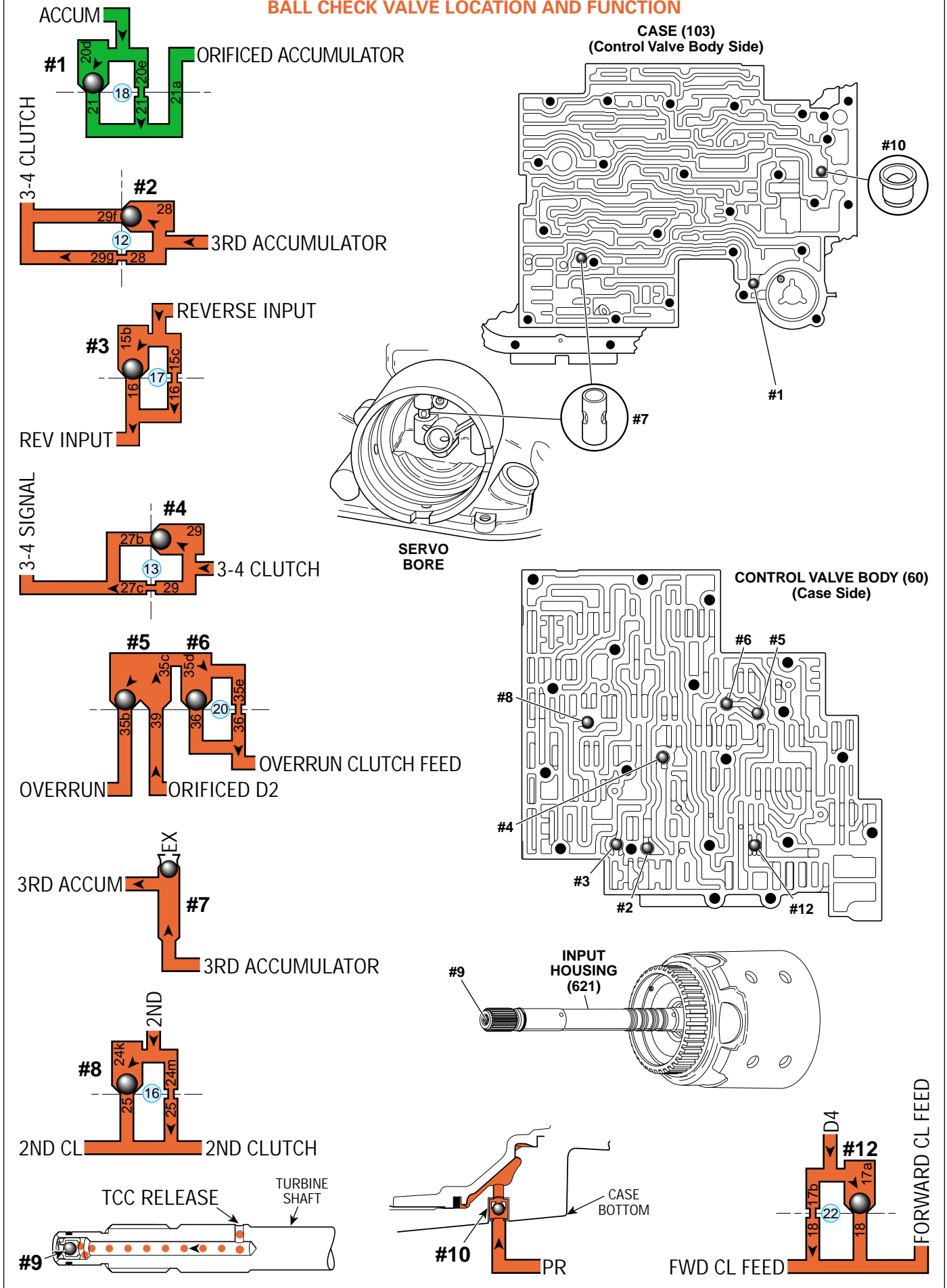

Figure 33

ELECTRICAL COMPONENTS

The Hydra-matic 4L60-E transmission incorporates electronic controls that utilize a Powertrain Control Module (PCM). The PCM gathers vehicle operating information from a variety of sensors and control components located throughout the powertrain (engine and transmission). The PCM then processes this information for proper control of the following:

- transmission shift points - through the use of shift solenoids
- transmission shift feel - by adjusting line pressure through the use of a pressure control solenoid
- TCC apply and release timing and feel - through the use of a TCC solenoid and a TCC PWM solenoid
- the 3-2 downshift - through the use of a 3-2 control solenoid

Electronic control of these transmission operating characteristics provides for consistent and precise shift points and shift quality based on the operating conditions of both the engine and transmission.

FAIL-SAFE MODE

“Fail-safe” mode is an operating condition when the transmission will partially function if a portion of the electronic control system becomes disabled. For example, if the wiring harness becomes disabled, the PCM commands the fail-safe mode which causes the electronic solenoids to default to OFF. The following changes occur when the transmission is operating in the fail-safe mode:

- the pressure control solenoid is OFF, increasing line pressure to a maximum to prevent any clutch or band slippage
- the TCC solenoid is OFF, preventing converter clutch apply

- the 3-2 control solenoid is OFF, providing a faster 3-2 downshift
- both shift solenoids are OFF

With both shift solenoids OFF, the transmission will operate in Third gear when the selector lever is in the Overdrive position. However, with the Hydra-matic 4L60-E transmission the driver has some flexibility in gear selection during fail-safe mode. Changing gears during fail-safe mode is accomplished by moving the gear selector lever as follows:

Gear Selector Lever Position	Transmission Gear Operation
Overdrive Range (D)	Third gear
Drive Range (D)	Third gear
Manual Second (2)	Second gear
Manual First (1)	Second gear
Reverse (R)	Reverse
Park, Neutral (P, N)	Park, Neutral

The downshift to First gear in Manual First is controlled electronically for safety and durability reasons. This means that the PCM must electronically command both shift solenoids to be ON to obtain First gear.

NOTE: This section of the book contains “general” information about electrical components that provide input information to the PCM. Since this “input” information may vary between vehicle applications, it is important that the appropriate General Motors Service Manual is used during repair or diagnosis of the transmission.

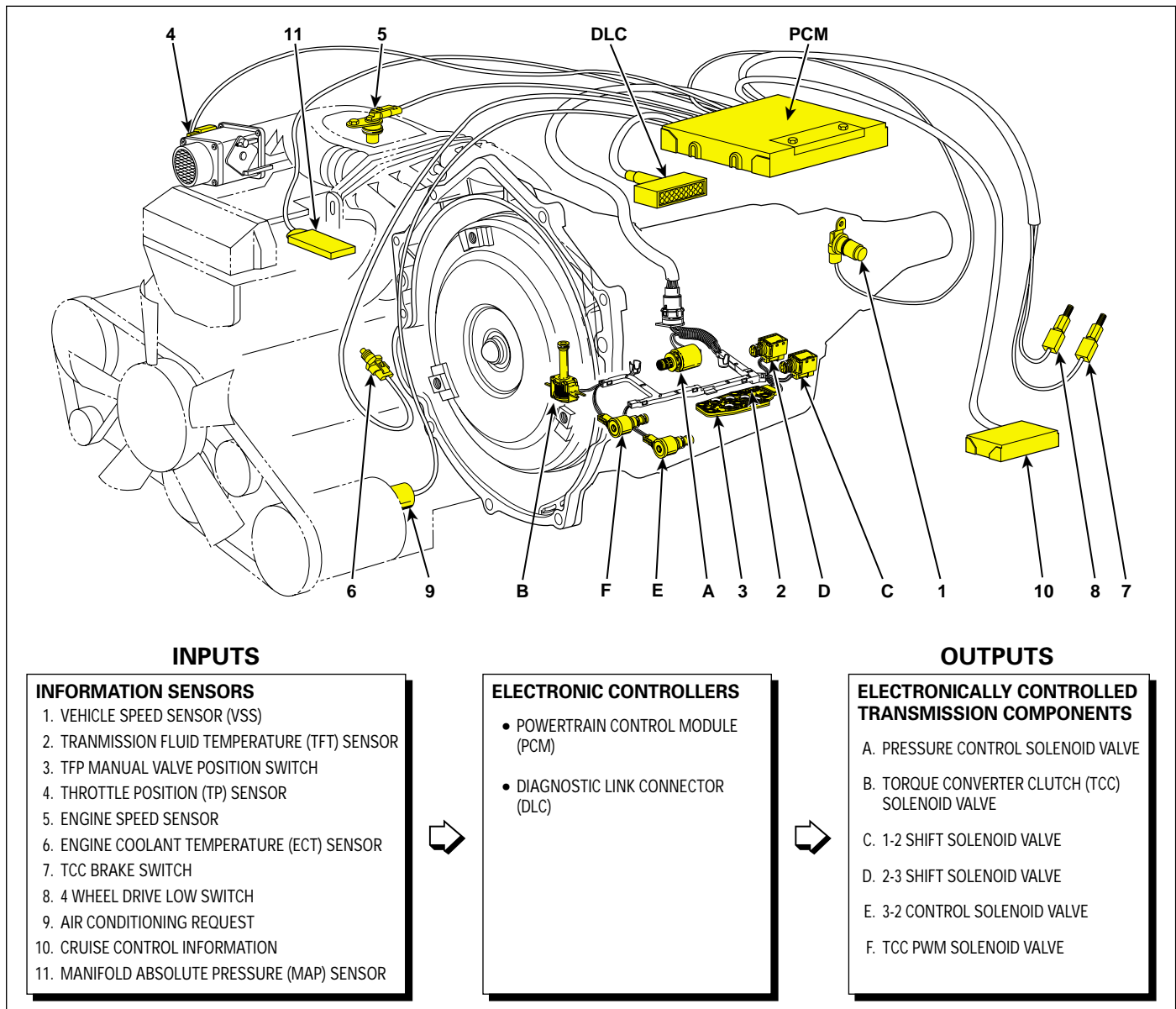
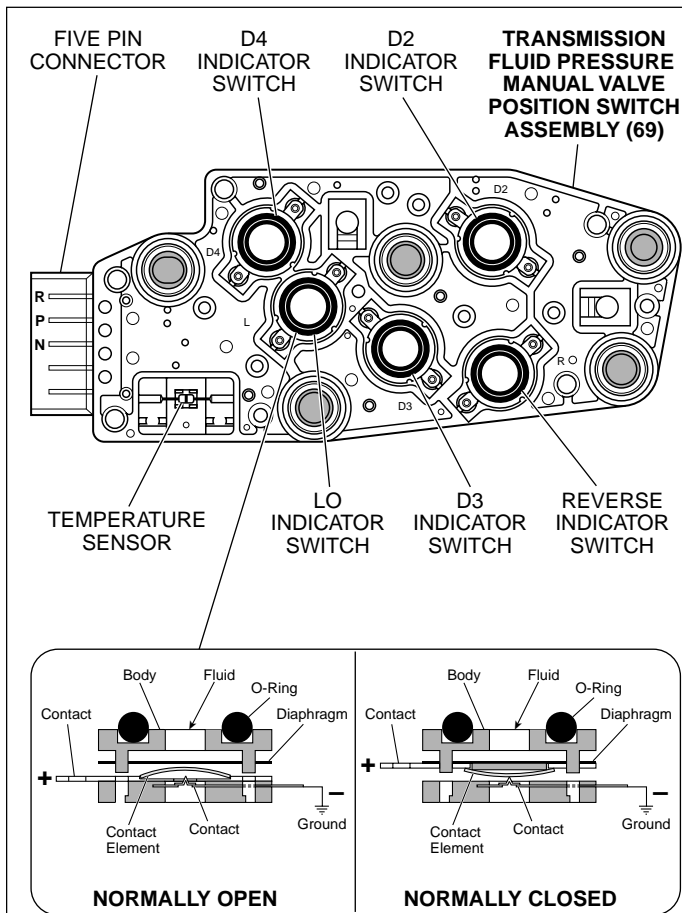

Figure 34



TRANSMISSION FLUID PRESSURE (TFP) MANUAL VALVE POSITION SWITCH ASSEMBLY

The TFP manual valve position switch assembly is attached to the control valve body and is used to signal the manual valve position to the PCM. Various fluids are routed to the TFP manual valve position switch depending on the manual valve position. These fluids open and close the fluid pressure switches in the TFP manual valve position switch to provide a signal to the PCM indicating the gear range position of the manual valve. The combination of opened and closed switches determines the voltage measured at each of the three pins in the TFP manual valve position switch electrical connector. An open circuit measures 12 volts while a grounded circuit measures 0 volts. The electrical schematic and chart below show the TFP manual valve position switch circuitry used to signal the manual valve position.

Normally Open Fluid Pressure Switch

The D4, Lo, and Reverse fluid pressure switches are normally open and electrical current is stopped at these switches when no fluid pressure is present. Fluid pressure moves the diaphragm and contact element until the contact element touches both the positive contact (+) and the ground contact (⊕). This creates a closed circuit and allows current to flow from the positive contact, through the switch and to ground.

Normally Closed Fluid Pressure Switch

The D2 and D3 fluid pressure switches are normally closed and electrical current is free to flow from the positive contact to the ground contact when no fluid pressure is present. Fluid pressure moves the diaphragm to disconnect the positive and ground contacts. This opens the switch and stops current from flowing through the switch.

Example: (Manual Third Range)

The hydraulic and electrical schematics below are shown in the Drive Range (Manual Third) position (D or 3). D4 fluid pressure closes the D4 fluid pressure switch and D3 fluid pressure opens the D3 fluid pressure switch. With the D2 switch normally closed, pins N and P measure 0 volts while pin R measures approximately 12 volts. This combination signals the PCM that the manual valve is in the Manual Third position.

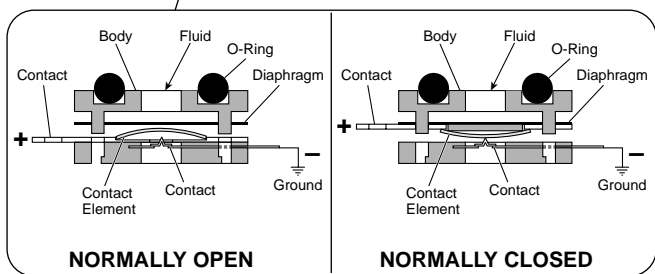

RANGE INDICATOR	FLUID*					CIRCUIT+		
	REV	D4	D3	D2	LO	N	R	P
Park/Neutral	0	0	0	0	0	0	1	0
Reverse	1	0	0	0	0	1	1	0
Overdrive	0	1	0	0	0	0	1	1
Manual Third	0	1	1	0	0	0	0	1
Manual Second	0	1	1	1	0	0	0	0
Manual First	0	1	1	1	1	1	0	0

*: 1 = Pressurized
0 = Exhausted

+ : 1 = Grounded (Resistance <50 ohms, 0 volts)
0 = Open (Resistance >50k ohms, 12 volts)

A Transmission Fluid Pressure Manual Valve Position Switch Assembly malfunction will set a DTC P1810 and the PCM will command the following default actions:

- Maximum line pressure.
- Assume D4 shift pattern.
- TCC on in commanded fourth gear.
- The PCM stores DTC P1810 in PCM history.

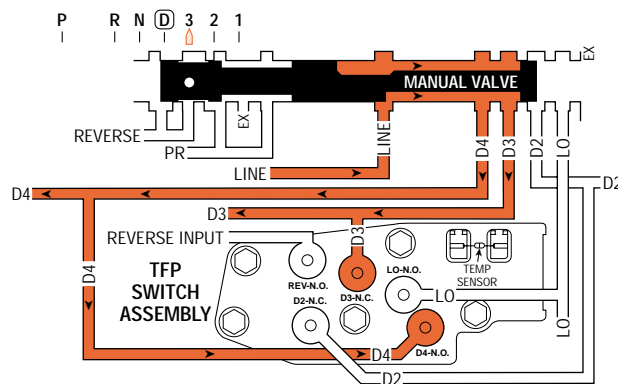
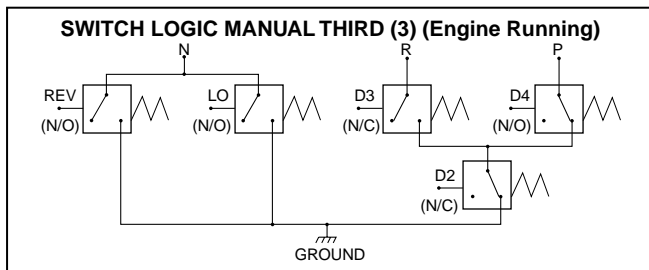

Figure 35

VEHICLE SPEED SENSOR (VSS)

The vehicle speed sensor is a magnetic inductive pickup that relays information relative to vehicle speed to the PCM. In two wheel drive (2WD) applications, the VSS is located on the transmission extension housing (31), opposite the speed sensor rotor. The speed sensor rotor is attached to the transmission output shaft and rotates with the output shaft at transmission output speed. The speed sensor rotor has 40 serrations, or teeth, cut into its outside diameter.

The VSS consists of a permanent magnet surrounded by a coil of wire. As the output shaft and speed sensor rotor rotate, an alternating current (AC) is induced in the coil of wire from the teeth on the rotor passing by the magnetic pickup on the VSS. Whenever the vehicle is moving, the VSS produces an AC voltage proportional to vehicle speed. This AC signal is sent to the digital ratio adaptor converter (DRAC) where it is converted to a direct current (DC) square wave form. The DC signal is then sent to the PCM and interpreted as vehicle speed. As vehicle speed increases and more rotor teeth pass by the magnetic pickup on the VSS in a given time frame, the frequency of the DC signal sent to the PCM increases. The PCM interprets this increase in frequency as an increase in vehicle speed (see Figure A).

Note: On four wheel drive (4WD) applications the VSS is located on the transfer case.

Vehicle Speed Sensor Circuit Low will set DTC P0502 and the PCM will command the following default actions:

- Freeze shift adapts.
- Maximum line pressure.
- Calculate A/T OSS from A/T ISS sensor output.
- DTC P0502 stores in PCM history.

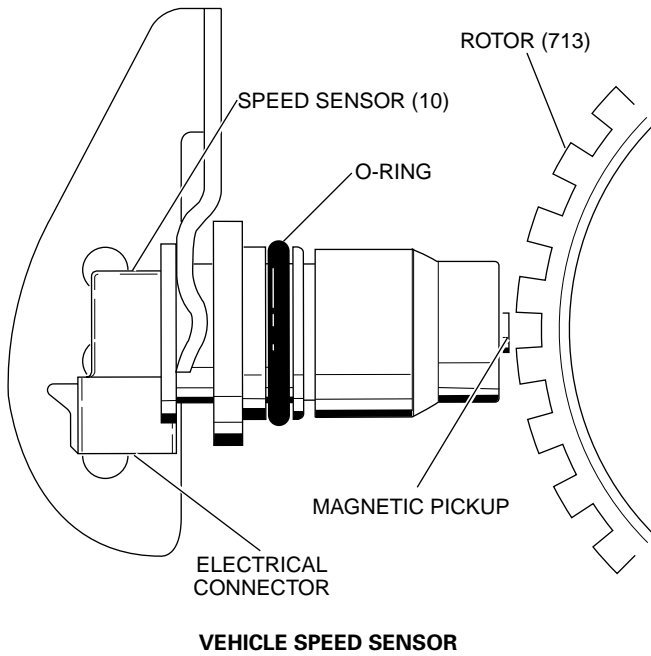

VEHICLE SPEED SENSOR

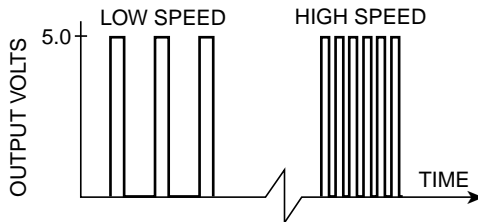
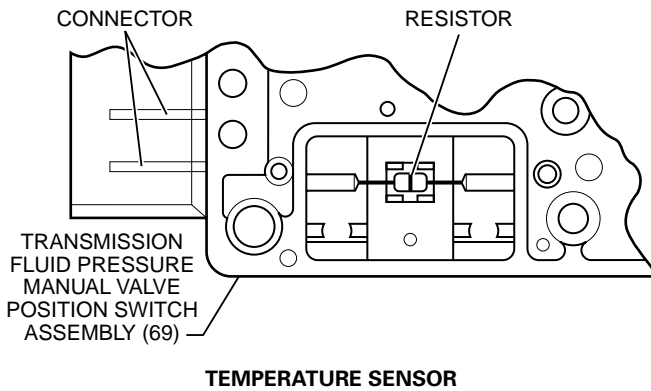

FIGURE A: CONDITIONED SIGNAL



TEMPERATURE SENSOR

TRANSMISSION FLUID TEMPERATURE (TFT) SENSOR

The temperature sensor is a negative temperature coefficient thermistor (temperature sensitive resistor) that provides information to the PCM regarding transmission fluid temperature. The temperature sensor is a part of the transmission fluid pressure (TFP) manual valve position switch assembly which is attached to the control valve body and submerged in fluid in the transmission bottom pan. The internal electrical resistance of the sensor varies in relation to the operating temperature of the transmission fluid (see chart). The PCM sends a 5 volt reference signal to the temperature sensor and measures the voltage drop in the circuit. A lower fluid temperature creates a higher resistance in the temperature sensor, thereby measuring a higher voltage signal.

The PCM measures this voltage as another input to help control TCC apply and line pressure. The PCM inhibits TCC apply until transmission fluid temperature reaches approximately 29°C (84°F). Also, when fluid temperatures exceed 135°C (275°F), the PCM commands TCC apply at all times in Fourth gear, as opposed to having a scheduled apply. Applying the TCC reduces fluid temperatures created by the fluid coupling in the converter.

TFT Sensor Circuit Range/Performance will set DTC P0711 and the PCM will command the following default actions:

- Freeze shift adapts.
- Defaults the TFT to 140°C (284°F) for shift scheduling (hot mode pattern).
- DTC P0711 stores in PCM history.

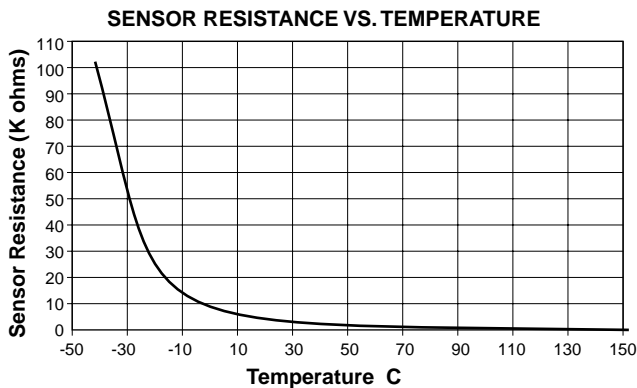

TORQUE CONVERTER CLUTCH SOLENOID

The TCC solenoid is a normally open, ON/OFF solenoid that the PCM controls to apply and release the converter clutch. When de-energized, converter feed fluid pressure holds the valve and plunger away from the exhaust port. This allows converter feed fluid to exhaust through the solenoid. Without converter feed fluid pressure at the end of the converter clutch apply valve, spring force holds the valve in the release position.

When vehicle operating conditions are appropriate for TCC apply, the PCM provides a ground for the TCC solenoid electrical circuit. Electrical current flows through the coil assembly in the solenoid which creates a magnetic field. The magnetic field moves the plunger and valve to block the exhaust port and prevent converter feed fluid from exhausting through the solenoid. Converter feed fluid pressure increases at the converter clutch apply valve and moves the valve into the apply position against spring force.

Under normal operating conditions, the torque converter clutch only applies in Fourth gear when in Overdrive range or Third gear when in Manual Third gear range. However, at high speeds under heavy throttle conditions, the PCM will command TCC apply in Third gear when in Overdrive range. Also, when transmission fluid temperature is above approximately 135°C (275°F), the TCC is applied all of the time in Fourth gear to help reduce transmission fluid temperatures. Other conditions that cause the PCM to change the operating state of the TCC solenoid include:

- The TCC is released when the brake pedal is depressed.
- The TCC is released under minimum and maximum throttle conditions.
- TCC apply is prevented until engine coolant temperature is above approximately 20°C (68°F).
- TCC apply is prevented until transmission fluid temperature is above approximately 29°C (84°F).

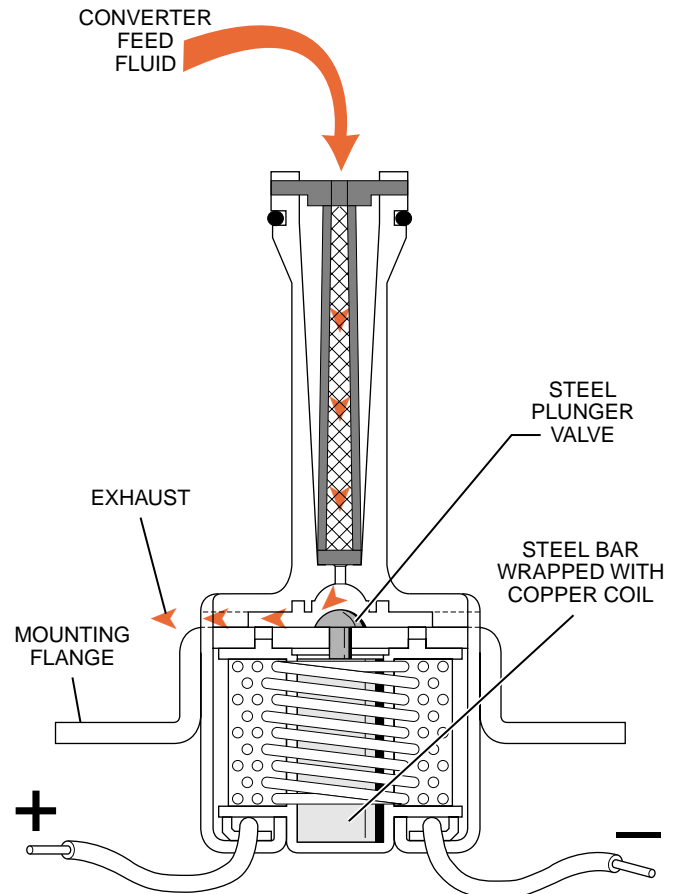

TORQUE CONVERTER CLUTCH SOLENOID (NORMALLY OPEN)

A continuous open, short to ground, or short to power in the TCC solenoid valve circuit will set DTC P0740 TCC Enable Solenoid Circuit Electrical and the PCM will command the following default actions:

- The PCM illuminates the malfunction indicator lamp (MIL)
- The PCM inhibits TCC engagement
- The PCM inhibits 4th gear if the transmission is in hot mode
- The PCM freezes shift adapts from being updated
- The PCM stores Freeze Frame and Failure records
- The PCM stores DTC P0740 in PCM history

Low torque converter slip when the TCC is commanded OFF will set DTC P0742 TCC System Stuck On and the PCM will command the following default actions:

- The PCM illuminates the malfunction indicator lamp (MIL)
- The PCM freezes shift adapts from being updated
- The PCM stores Freeze Frame and Failure records
- The PCM stores DTC P0742 in PCM history

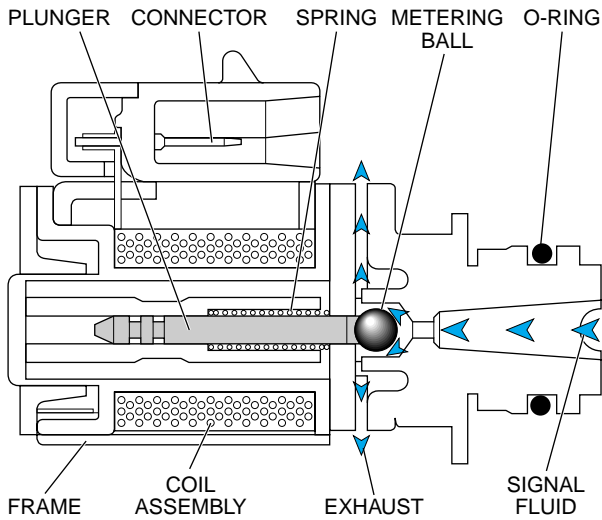

SHIFT SOLENOID VALVE (OFF)

SHIFT SOLENOID VALVES

The Hydra-matic 4L60-E transmission uses two identical, normally open, electronic shift solenoid valves (1-2 and 2-3) to control upshifts and downshifts in all forward gear ranges. These shift solenoid valves work together in a combination of ON and OFF sequences to control the positions of the 1-2 shift valve, 2-3 shift valve train and 3-4 shift valve. The PCM monitors numerous inputs to determine the appropriate solenoid state combination and transmission gear for the vehicle operating conditions. The following table shows the solenoid state combination required to obtain each gear:

GEAR	1-2 SOLENOID	2-3 SOLENOID
Park, Reverse, Neutral	ON	ON
First	ON	ON
Second	OFF	ON
Third	OFF	OFF
Fourth	ON	OFF

Shift Solenoid De-energized (OFF)

The shift solenoids are OFF when the PCM opens the path to ground for the solenoid's electrical circuit. When OFF, solenoid signal fluid pressure (blue color) moves the metering ball and plunger against spring force, away from the fluid inlet port. Solenoid signal fluid is then open to an exhaust port located on the side of the solenoid.

Shift Solenoid Energized (ON)

To energize the shift solenoids, the PCM provides a path to ground for the solenoid's electrical circuit. Electrical current passing through the coil assembly in the solenoid creates a magnetic field that magnetizes the solenoid core. The magnetized core repels the plunger which seats the metering ball against the fluid inlet port. With the ball seated, solenoid signal fluid is blocked from exhausting, thereby creating fluid pressure in the solenoid signal fluid circuit.

1-2 Shift Solenoid (SS) Valve

Located at the end of the 1-2 shift valve, the 1-2 SS valve controls the position of the 1-2 and 3-4 shift valves. The solenoid is fed 1-2 signal fluid by the actuator feed limit fluid (AFL) circuit through orifice #25. When energized (Example "A"), the solenoid blocks 1-2 signal fluid from exhausting, thereby creating pressure in the 1-2 signal fluid circuit. 1-2 signal fluid pressure holds the 1-2 shift valve against spring force (downshifted position) in Park, Reverse, Neutral and First gears. In Fourth gear, D432 fluid pressure assists spring force to keep the 1-2 shift valve in the upshifted position against 1-2 signal fluid pressure. Also, 1-2 signal fluid pressure holds the 3-4 shift valve in the upshifted position against spring force.

When the 1-2 SS valve is de-energized in Second and Third gears (Example "B"), 1-2 signal fluid exhausts through the solenoid. Spring force holds the 1-2 shift valve in the upshifted position and the 3-4 shift valve in the downshifted position.

2-3 Shift Solenoid (SS) Valve

Located at the end of the 2-3 shuttle valve, the 2-3 SS valve controls the position of the 2-3 shift valve train. The solenoid is fed 2-3 signal fluid by the AFL fluid circuit through orifice #29. When energized by the PCM (Example "A"), 2-3 signal fluid pressure holds the 2-3 shift valve train in the downshifted position against AFL fluid pressure acting on the 2-3 shift valve.

When de-energized [Third and Fourth gears (Example "B")], 2-3 signal fluid exhausts through the solenoid. This allows AFL fluid pressure acting on the 2-3 shift valve to move the shift valve train into the upshifted position. In Manual Second, D2 fluid pressure holds the 2-3 shift valve in the downshifted position against AFL fluid pressure regardless of the 2-3 SS valve state.

Note: The feed orifices (#25 and #29) between the AFL and solenoid signal fluid circuits are smaller than the exhaust ports through the solenoids. This prevents fluid pressure buildup in the solenoid signal fluid circuits at the end of the shift valves when the shift solenoids are OFF.

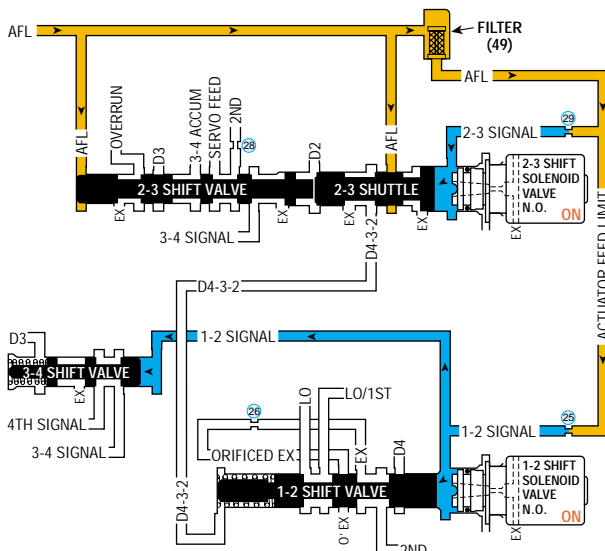

EXAMPLE A: PARK/REVERSE/NEUTRAL/FIRST GEAR

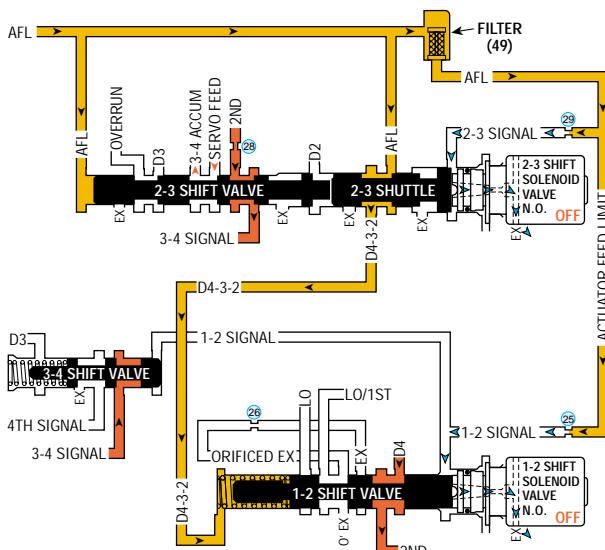

EXAMPLE B: THIRD GEAR

3-2 CONTROL SOLENOID VALVE

The 3-2 control solenoid valve is a normally closed, 3-port ON/OFF solenoid used to control the 3-2 downshift. During a 3-2 downshift, the 2-4 band is applied as the 3-4 clutch releases. The timing between the 3-4 clutch release and 2-4 band apply must be varied depending on vehicle speed and throttle position (see downshift timing below). The 3-2 control solenoid valve feeds AFL fluid into the 3-2 signal fluid circuit. 3-2 signal fluid pressure shifts the 3-2 control valve to provide for these varying requirements and achieve a precise control of the 3-2 downshift.

The solenoid is constantly fed 12 volts to the high (positive) side and the PCM controls when the path to ground for the electrical circuit is closed. When the PCM closes the solenoid ground circuit, current flows through the solenoid and the ground circuit is at a low voltage state (0 volts and solenoid energized).

Solenoid De-energized

When the solenoid is OFF, no current flows to the solenoid coil. Spring force holds the plunger and metering ball against the fluid inlet port to block AFL fluid from entering the 3-2 signal fluid circuit. The 3-2 signal fluid circuit is open to an exhaust through the solenoid. With the 3-2 signal fluid circuit empty, spring force holds the 3-2 control valve open.

Solenoid Energized

The position of the metering ball is controlled by current flowing through the solenoid coil. Current flowing through the solenoid coil creates a magnetic field which moves the plunger and ball against spring force to block the exhaust port thereby increasing 3-2 signal fluid pressure and the 3-2 control valve shifts.

3-2 Downshift Timing

The PCM energizes the 3-2 control solenoid valve when the transmission is in Second, Third and Fourth gears. In all other gear ranges, the solenoid is OFF. During a 3-2 downshift, the solenoid is turned ON or OFF according to vehicle speed.

At lower vehicle speeds, the PCM operates the 3-2 control solenoid valve in the OFF position. In the OFF position, the solenoid is open, allowing AFL fluid to exhaust. With no AFL fluid pressure entering the 3-2 signal fluid circuit, the 3-2 control valve is kept in the open position by spring force to allow a faster exhaust of 3rd accumulator fluid through an orifice into the 3-4 clutch fluid circuit. A faster exhaust of the 3rd accumulator exhaust fluid provides a faster apply of the 2-4 band, as needed at lower vehicle speeds.

At high vehicle speed, the PCM operates the 3-2 control solenoid valve in the ON position allowing actuator feed limit fluid to pass into the 3-2 signal fluid circuit. The 3-2 signal fluid pressure shifts the 3-2 control solenoid into the closed position. This action permits a slow apply of the 2-4 band by blocking off 3rd accumulator exhaust fluid from entering the 3-4 clutch fluid circuit. This allows the engine speed to easily come up to the necessary RPM before the 2-4 band is applied.

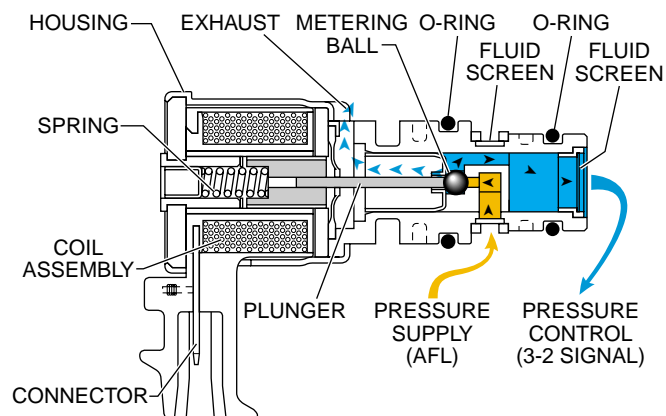

3-2 CONTROL SOLENOID VALVE

When the PCM detects a continuous open, short to ground or short to power in the 3-2 SS valve assembly circuit, then DTC P0785 3-2 Shift Solenoid Circuit Electrical sets and the PCM will command the following default actions:

- The PCM illuminates the malfunction indicator lamp (MIL)
- The PCM commands a soft landing to third gear
- The PCM commands maximum line pressure
- The PCM inhibits TCC engagement
- The PCM inhibits 4th gear if the transmission is in hot mode
- The PCM freezes shift adapts from being updated
- The PCM stores Freeze Frame and Failure records
- The PCM stores DTC P0785 in PCM history

ELECTRICAL COMPONENTS

Pressure Control Solenoid Valve

The pressure control (PC) solenoid valve is a precision electronic pressure regulator that controls transmission line pressure based on current flow through its coil windings. As current flow is increased, the magnetic field produced by the coil moves the solenoid's plunger further away from the exhaust port. Opening the exhaust port decreases the output fluid pressure regulated by the PC solenoid valve, which ultimately decreases line pressure. The PCM controls the PC solenoid valve based on various inputs including throttle position, transmission fluid temperature, MAP sensor and gear state.

Duty Cycle, Frequency and Current Flow

A "duty cycle" may be defined as the percent of time current is flowing through a solenoid coil during each cycle. The number of cycles that occur within a specified amount of time, usually measured in seconds, is called "frequency". Typically, the operation of an electronically controlled pulse width modulated solenoid is explained in terms of duty cycle and frequency.

The PCM controls the PC solenoid valve on a positive duty cycle at a fixed frequency of 292.5 Hz (cycles per second). A higher duty cycle provides a greater current flow through the solenoid. The high (positive) side of the PC solenoid valve electrical circuit at the PCM controls the PC solenoid valve operation. The PCM provides a ground path for the circuit, monitors average current and continuously varies the PC solenoid valve duty cycle to maintain the correct average current flowing through the PC solenoid valve.

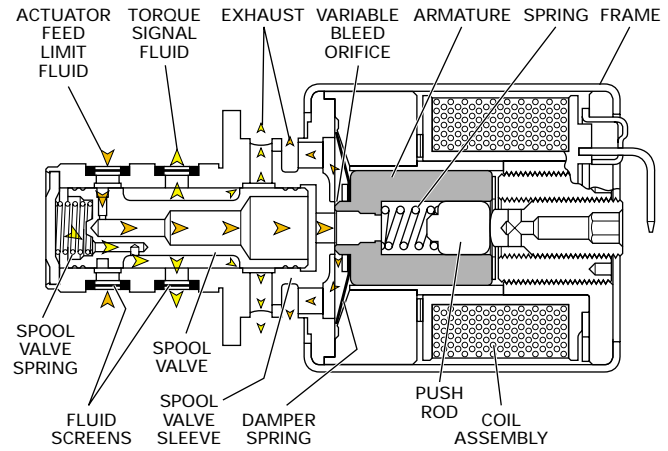

PRESSURE CONTROL SOLENOID VALVE

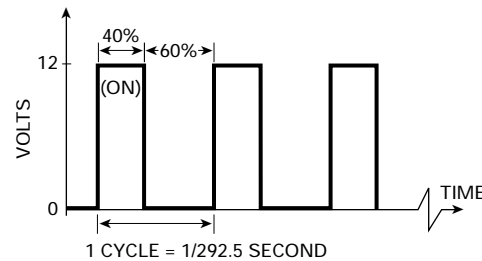

PRESSURE CONTROL SOLENOID VALVE POSITIVE DUTY CYCLE

Approximate Duty Cycle	Current	Line Pressure
+ 5%	0.1 Amps	Maximum
+40%	1.1 Amps	Minimum

Pressure control solenoid valve resistance should measure between 3.5 and 4.6 ohms when measured at 20°C (68°F).

The duty cycle and current flow to the PC solenoid valve are mainly affected by throttle position (engine torque) and they are inversely proportional to throttle angle (engine torque). In other words, as the throttle angle (engine torque increases), the duty cycle is decreased by the PCM which decreases current flow to the PC solenoid valve. Current flow to the PC solenoid valve creates a magnetic field that moves the solenoid armature toward the push rod and against spring force.

Transmission Adapt Function:

Programming within the PCM also allows for automatic adjustments in shift pressure that are based on the changing characteristics of the transmission components. As the apply components within the transmission wear, shift time (time required to apply a clutch or band) increases. In order to compensate for this wear, the PCM adjusts trim pressure by controlling the PC solenoid valve in order to maintain the originally calibrated shift timing. The automatic adjusting process is referred to as "adaptive learning" and it is used to assure consistent shift feel plus increase transmission durability. The PCM monitors the A/T ISS sensor and A/T OSS during commanded shifts to determine if a shift is occurring too fast (harsh) or too slow (soft) and adjusts the PC solenoid valve signal to maintain a set shift feel.

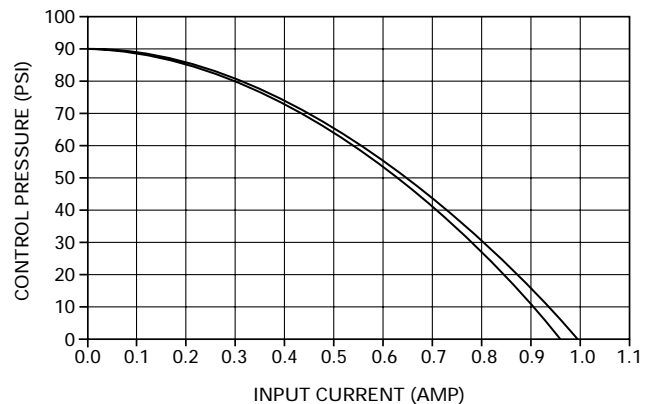

PRESSURE CONTROL SOLENOID VALVE CURRENT FLOW

A Pressure Control Solenoid electrical problem will set a DTC P0748 and the PCM will command the following default actions:

- Disable the PC solenoid valve.
- Freeze shift adapts.
- DTC P0748 stores in PCM history.

Transmission adapts must be reset whenever the transmission is overhauled or replaced (see appropriate service manual).

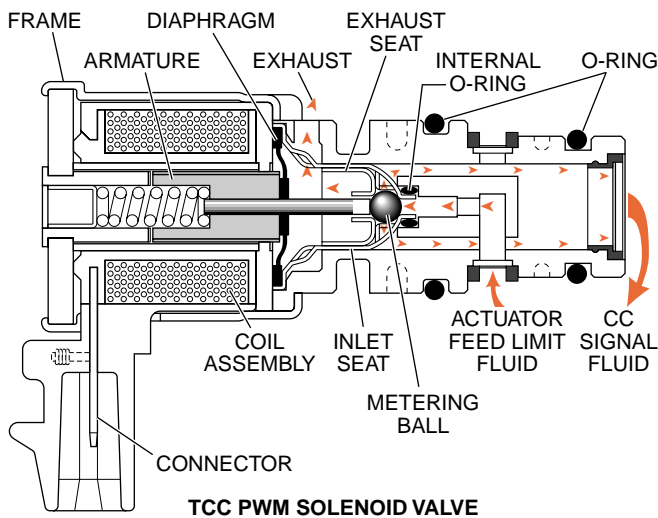

Torque Converter Clutch Pulse Width Modulated (TCC PWM) Solenoid Valve

The TCC PWM solenoid valve is a normally closed, pulse width modulated (PWM) solenoid used to control the apply and release of the converter clutch. The PCM operates the solenoid with a negative duty cycle at a fixed frequency of 32 Hz to control the rate of TCC apply/release. The solenoid's ability to "ramp" the TCC apply and release pressures results in a smoother TCC operation.

TCC PWM Solenoid Valve Operation

The TCC PWM solenoid valve is one electronic control component of the TCC apply and release system. The other electronic component is the TCC solenoid valve, which enables TCC ON and OFF. The other components are all hydraulic control or regulating valves. The illustration below shows all the valves and the TCC PWM solenoid valve that make up the TCC control system. (For more information on system operation see pages 62 and 63 in the Powerflow section.)

In first gear, at approximately 13 km/h (8 mph), the PCM operates the TCC PWM solenoid valve at approximately 90 percent duty cycle (point S on the graph at left). This duty cycle is maintained until a TCC apply is commanded. When vehicle operating conditions are appropriate to apply the TCC, the PCM immediately decreases the duty cycle to 0 percent, then increases it to approximately 25% (see point C on graph). The PCM then ramps the duty cycle up to approximately 50% to achieve regulated apply pressure in vehicles equipped with the Electronically Controlled Clutch Capacity. With the ECC system, the pressure plate does not fully lock to the torque converter, instead a consistent slip of 20 to 40 RPM is regulated. The rate at which the PCM increases the duty cycle controls the TCC apply. Similarly, the PCM also ramps down the TCC solenoid duty cycle to control TCC release. Under some high torque or high vehicle speeds, the converter clutch is fully locked.

There are some operating conditions that prevent or enable TCC apply under various conditions (refer to the Automatic Transmission Fluid Temperature sensor description). Also, if the PCM receives a high voltage signal from the brake switch, signalling that the brake pedal is depressed, the PCM immediately releases the TCC.

Note: Duty cycles given are for example only. Actual duty cycles will vary depending on vehicle application and vehicle operating conditions.

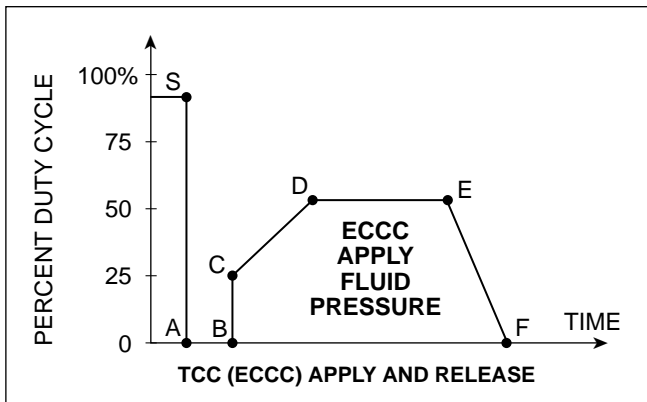

When the PCM detects a continuous open, short to ground or short to power in the TCC PWM solenoid valve circuit, then DTC P1860 sets and the PCM will command the following default actions:

- The PCM illuminates the malfunction indicator lamp (MIL)
- The PCM inhibits TCC engagement
- The PCM inhibits 4th gear if the transmission is in hot mode
- The PCM freezes shift adapts from being updated
- The PCM stores Freeze Frame and Failure records
- The PCM stores DTC P1860 in PCM history

TCC PWM solenoid valve resistance should measure between 10.0 and 11.5 ohms when measured at 20°C (68°F). The resistance should measure between 15.0 and 17 ohms at 150°C (302°F).

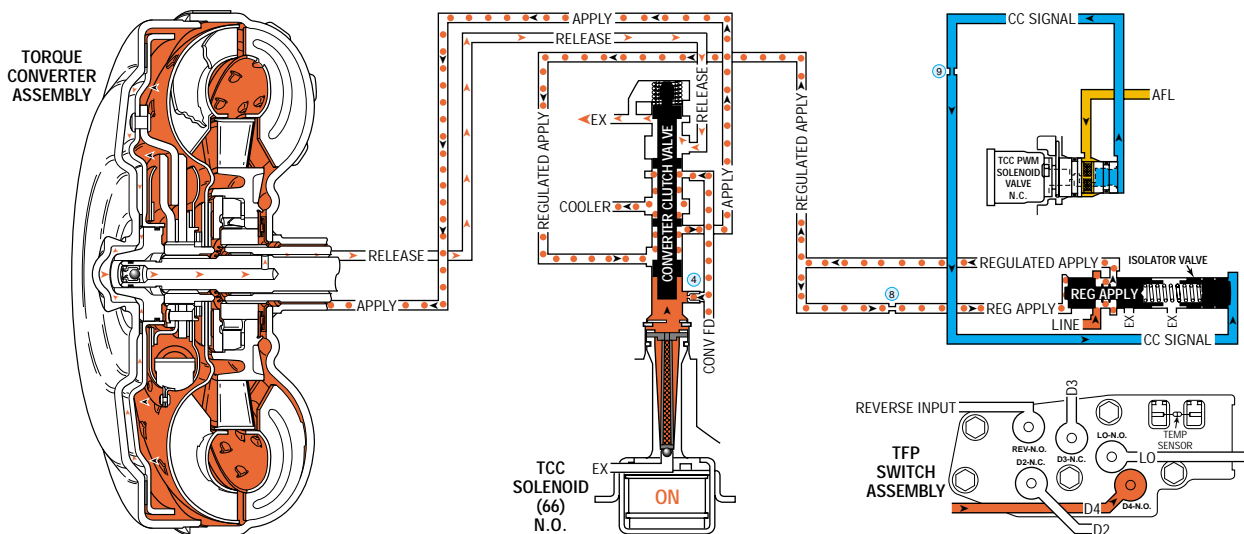

Figure 41

ELECTRICAL COMPONENTS EXTERNAL TO THE TRANSMISSION

THROTTLE POSITION (TP) SENSOR

The TPS is a potentiometer mounted to the throttle body that provides the PCM with information relative to throttle angle (accelerator pedal movement). The PCM provides a 5 volt reference signal and a ground to the TPS and the sensor returns a signal voltage that changes with throttle valve angle. This signal varies from less than 1.0 volt at minimum throttle to nearly 5.0 volts at wide-open throttle. The PCM uses this information to modify fuel control, shift patterns, shift feel and TCC apply and release timing. In general, with greater accelerator pedal travel and higher TPS voltage signal, the following conditions occur:

- The PCM delays upshifts or initiates a downshift (through the shift solenoids) for increased acceleration.
- The PCM increases line pressure (through the pressure control solenoid) to increase the holding force on the clutches and/or band.
- The PCM keeps the TCC released during heavy acceleration. The TCC is also released during minimum acceleration.

ENGINE COOLANT TEMPERATURE (ECT) SENSOR

The ECT sensor is a negative temperature coefficient resistor (temperature sensitive resistor) mounted in the engine coolant stream. Low coolant temperature produces high resistance in the sensor while high coolant temperature produces low resistance. With respect to transmission operation, the PCM monitors the voltage signal from the sensor, which is high at low coolant temperatures, to prevent TCC apply when coolant temperature is below approximately 20°C (68°F).

ENGINE SPEED SENSOR

The PCM monitors engine speed as RPM through the ignition module for gasoline engines. For diesel engine applications, a separate engine speed sensor is used to monitor engine speed from the crankshaft. This information is used to help determine shift patterns and TCC apply and release timing.

TCC BRAKE SWITCH

The TCC brake switch is a normally closed switch when the brake pedal is in the released position. When the brake pedal is depressed, the switch is open and the PCM commands TCC release.

AIR CONDITIONING (A/C) SWITCH SIGNAL

When the A/C cycling switch closes, the PCM is signaled that the A/C compressor is ON. The PCM uses this information to adjust transmission line pressure, shift timing and TCC apply timing.

CRUISE CONTROL INFORMATION

The PCM monitors input signals from the cruise control switch to alter shift patterns when the cruise control is engaged. Depending on application, the PCM alters the shift pattern to require a time limit to be met between the 3-2/2-3 shifts and the 4-3/3-4 shifts. This time limit prevents the transmission from upshifting to quickly after downshifting when the cruise control is engaged.

FOUR WHEEL DRIVE (4WD) LOW SWITCH

With 4WD applications, the VSS is located on the transfer case. The 4WD Low switch signals the PCM that the vehicle is operating in 4WD Low. The PCM then multiplies transfer case output speed signal by the transfer case ratio in low range to determine the transmission output shaft speed. The PCM uses this information to provide earlier upshifts and prevent an overspeed condition when operating in 4WD low.

MANIFOLD ABSOLUTE PRESSURE (MAP) SENSOR

The MAP sensor measures changes relative to intake manifold pressure which results from changes in engine load and speed. These changes are converted to a voltage output which is monitored by the PCM in order to adjust line pressure and shift timing.

ASSEMBLY LINE DIAGNOSTIC LINK (ALDL)

The ALDL is a multi-terminal connector wired to the PCM that is located under the vehicle dash. The ALDL can be used to diagnose conditions in the vehicle's electrical system, PCM and the transmission's electrical components. Refer to the appropriate General Motors Service Manual for specific electrical diagnosis information.

POWERFLOW

This section of the book describes how torque from the engine is transferred through the Hydra-matic 4L60-E transmission allowing the vehicle to move either in a forward or reverse direction. The information that follows details the specific mechanical operation, electrical, hydraulic and apply components that are required to achieve a gear operating range.

The full size, left hand pages throughout this section contain drawings of the mechanical components used in a specific range and gear. Facing this full page is a half page insert containing a color coded range reference chart at the top. This chart is one of the key items used to understand the mechanical operation of the transmission in each range and gear. The text below this chart provides a detailed explanation of what is occurring mechanically in that range and gear.

The full size, right hand pages contain a simplified version of the Complete Hydraulic Circuit that is involved for that range and gear. Facing this full page is a half page insert containing text and a detailed explanation of what is occurring hydraulically in that range and gear. A page number located at the bottom of the half page of text provides a ready reference to the complete Hydraulic Circuits section of this book if more detailed information is desired.

It is the intent of this section to provide an overall simplified explanation of the mechanical, hydraulic and electrical operation of the Hydra-matic 4L60-E transmission. If the operating principle of a clutch, band or valve is unclear, refer to the previous sections of this book for individual component descriptions.

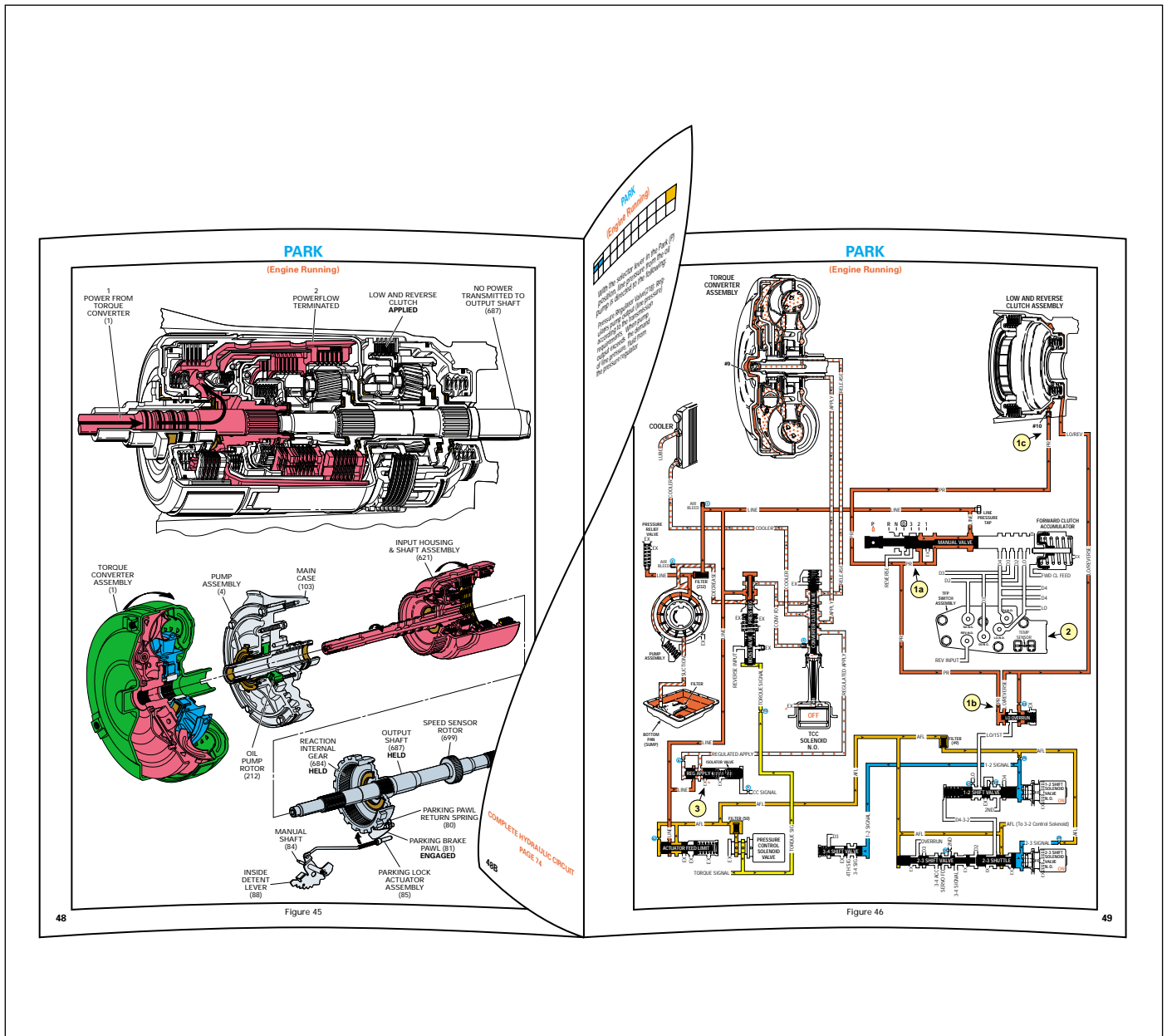
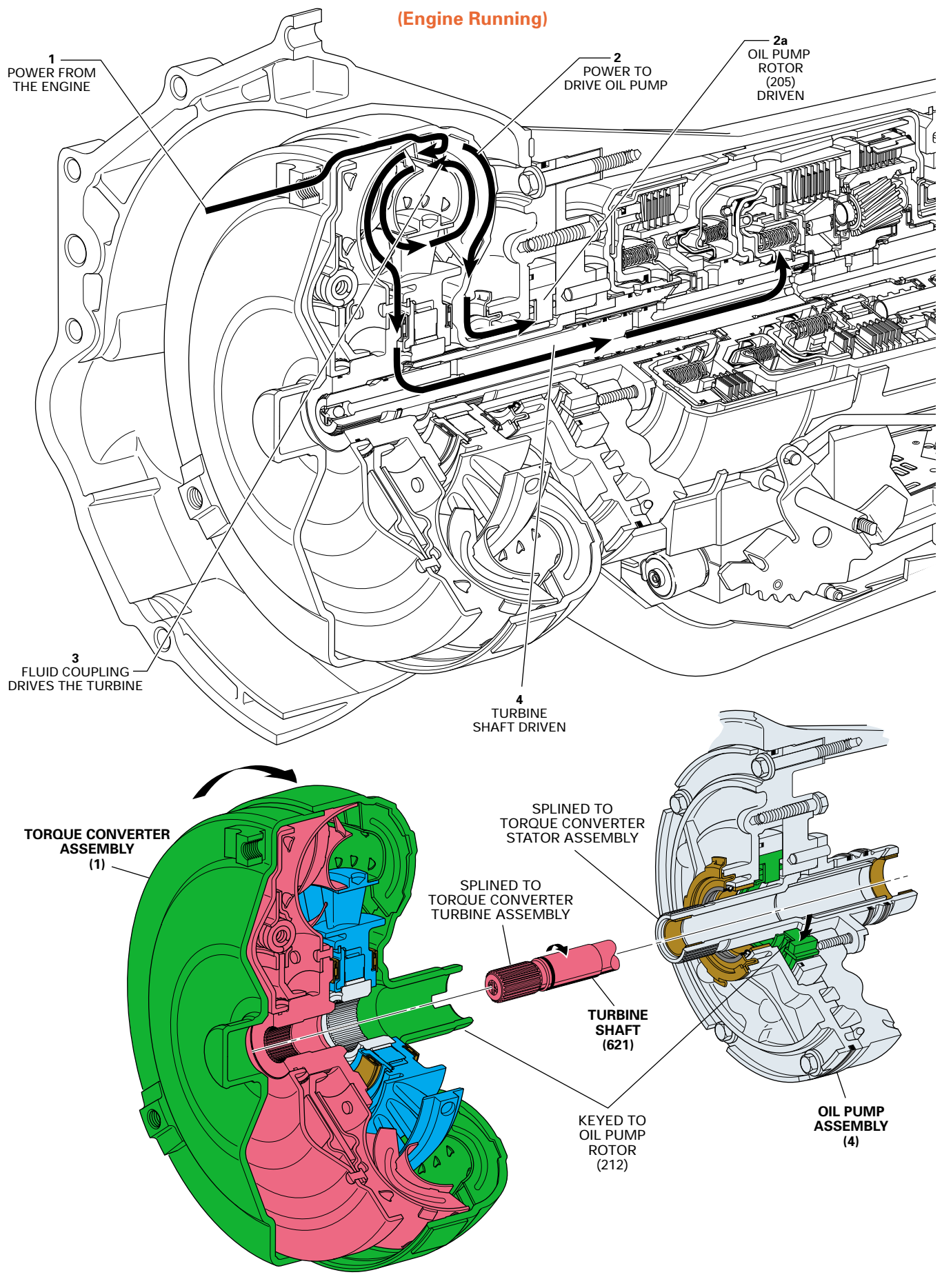

Figure 42

MECHANICAL POWERFLOW FROM THE TORQUE CONVERTER TO THE TURBINE SHAFT

(Engine Running)



MECHANICAL POWERFLOW FROM THE TORQUE CONVERTER TO THE TURBINE SHAFT

(Engine Running)

The mechanical power flow in the Hydra-matic 4L60-E transmission begins at the point of connection between the torque converter and the engine flywheel. When the engine is running, the torque converter cover (pump) is forced to rotate at engine speed. As the torque converter rotates it multiplies engine torque and transmits it to the input housing and turbine shaft assembly (621). The turbine shaft provides the primary link to the mechanical operation of the transmission.

The Hydra-matic 4L60-E automatic transmission requires a constant supply of pressurized fluid to cool and lubricate all of the components throughout the unit. It also requires a holding force to be applied to the bands and clutches during the various gear range operations. The oil pump assembly (4) and control valve body assembly (60) provide for the pressurization and distribution of fluid throughout the transmission.

- 1 Power from the Engine**
Torque from the engine is transferred to the transmission through the engine flywheel which is bolted to the torque converter.
- 2 Power to Drive the Oil Pump**
The oil pump rotor (212) is keyed to the torque converter hub. Therefore, the oil pump rotor also rotates at engine speed.
- 3 Fluid Coupling Drives the Turbine**
Transmission fluid inside the torque converter (1) creates a fluid coupling which in turn drives the torque converter turbine.
- 4 Input Housing and Turbine Shaft Assembly Driven**
As the torque converter turbine rotates, the input housing and turbine shaft assembly (621), which is splined to the torque converter turbine, is also forced to rotate at turbine speed.

NOTE: To minimize the amount of repetitive text, the remaining mechanical power flow descriptions will begin with the input housing and turbine shaft assembly (621). The transfer of torque from the engine through the torque converter to the turbine shaft is identical in all gear ranges.

HYDRAULIC POWERFLOW – COMMON FUNCTIONS FOR ALL RANGES

(Engine Running)

When the gear selector lever is in the Park (P) position and the engine is running, fluid is drawn into the oil pump and line pressure is directed to the pressure regulator valve.

1 PRESSURE REGULATION

1a Pressure Regulator Valve:

Regulates pump output (line pressure) in response to torque signal fluid pressure acting on the reverse boost valve, spring force, and line pressure acting on the end of the valve. Line pressure is directed to the manual valve, the regulated apply valve, and the actuator feed limit valve. Also, line pressure feeds the converter feed circuit through the pressure regulator valve.

1b Actuator Feed Limit (AFL) Valve:

Line pressure is routed through the valve and into the actuator feed fluid circuit. The valve limits actuator feed fluid pressure to a maximum pressure. Actuator feed fluid is routed to the pressure control solenoid valve, the TCC PWM solenoid valve, the 3-2 control solenoid valve, and also feeds the 1-2 signal and 2-3 signal fluid circuits.

1c Pressure Control (PC) Solenoid Valve:

Controlled by the PCM, the PC solenoid valve regulates filtered actuator feed limit fluid pressure into the torque signal fluid circuit.

2 SHIFT ACCUMULATION

2a Accumulator Valve:

D4 pressure is regulated into accumulator fluid pressure. This regulation is basically controlled by torque signal fluid pressure acting on one end of the valve and orificed accumulator fluid on the other end of the valve.

2b 1-2 and 3-4 Accumulator Assemblies:

Accumulator fluid is routed to each of the accumulator assemblies in preparation for upshifts and downshifts.

2c 2nd & 4th Servo:

In 3rd gear, 4th gear and manual 3rd gear, 3rd accumulator fluid is routed to the 2nd & 4th servo, which acts as an accumulator for the 3-4 clutch.

3 TORQUE CONVERTER (RELEASED POSITION ONLY)

3a Pressure Regulator Valve:

Line pressure is routed through the pressure regulator valve and into the converter feed fluid circuit. Converter feed fluid is routed to the converter clutch valve.

3b TCC PWM Solenoid Valve:

Actuator feed limit fluid is routed from the actuator feed limit valve to the TCC PWM solenoid valve where it stops in preparation for torque converter clutch apply.

3c Regulated Apply Valve:

Line pressure is routed through the regulated apply valve into the regulated apply fluid circuit. Regulated apply fluid is routed to the converter clutch valve in preparation for TCC apply.

3d TCC Solenoid Valve:

Converter feed fluid is supplied to the TCC solenoid valve in preparation for torque converter clutch apply.

3e Converter Clutch Valve:

Spring force holds the valve in the release position allowing regulated converter feed fluid to enter the release circuit. Release fluid is routed to the torque converter. Apply fluid from the torque converter also passes through the converter clutch valve into the cooler circuit.

3f Torque Converter:

Release fluid pressure is routed to the torque converter to keep the TCC released. Fluid leaves the converter in the apply fluid circuit and returns to the cooler through the converter clutch valve.

COMMON HYDRAULIC FUNCTIONS FOR ALL RANGES

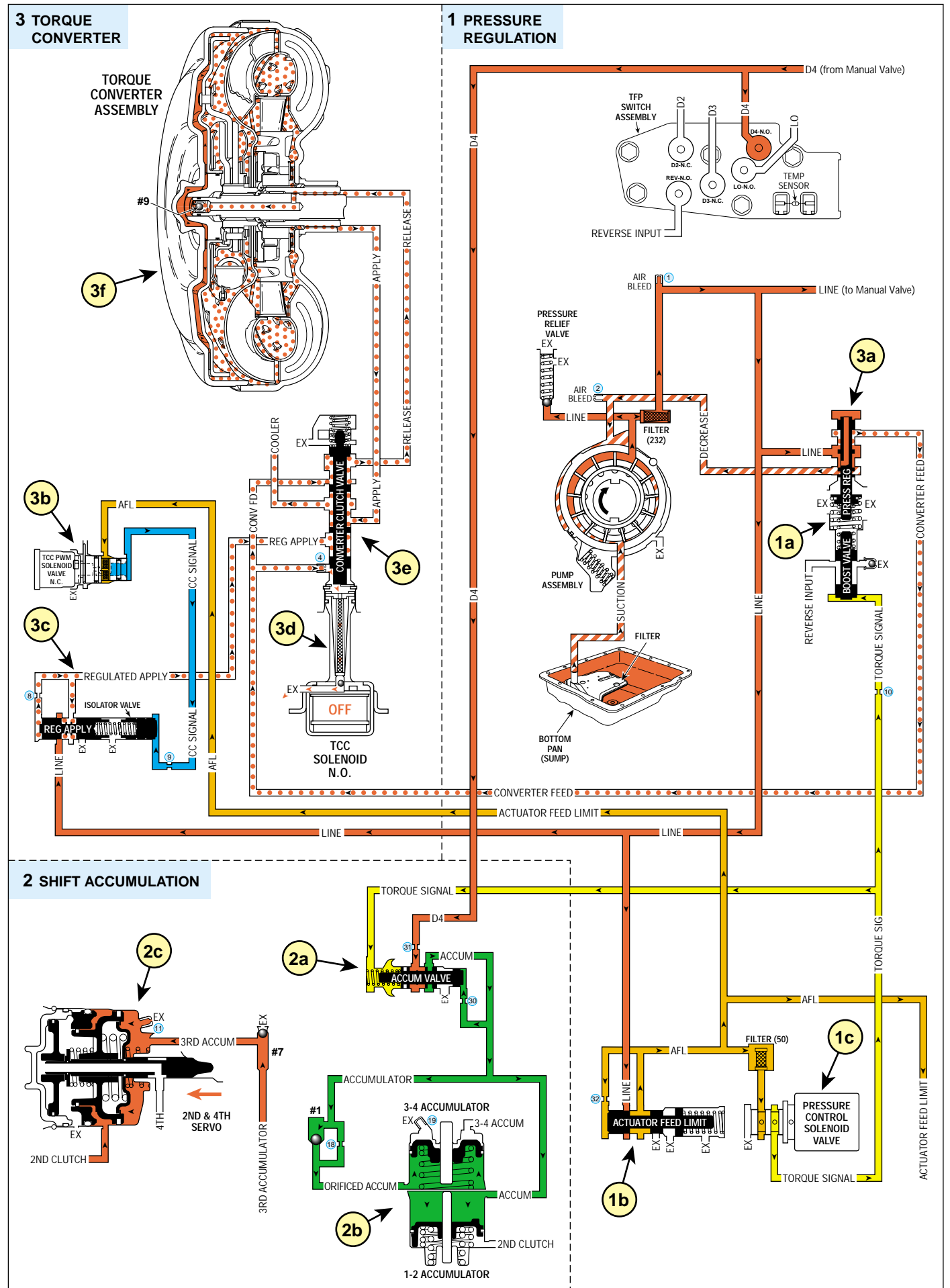
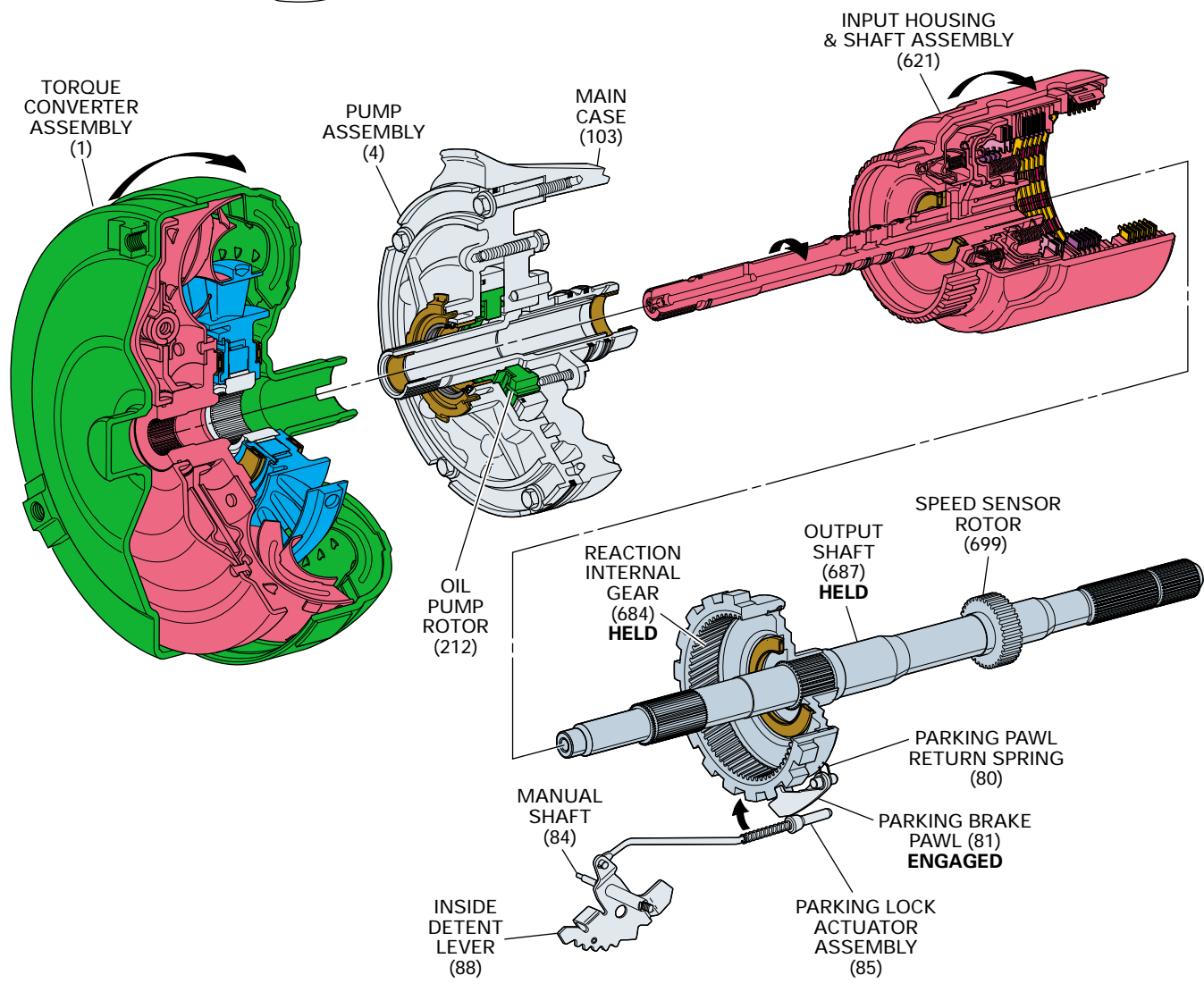
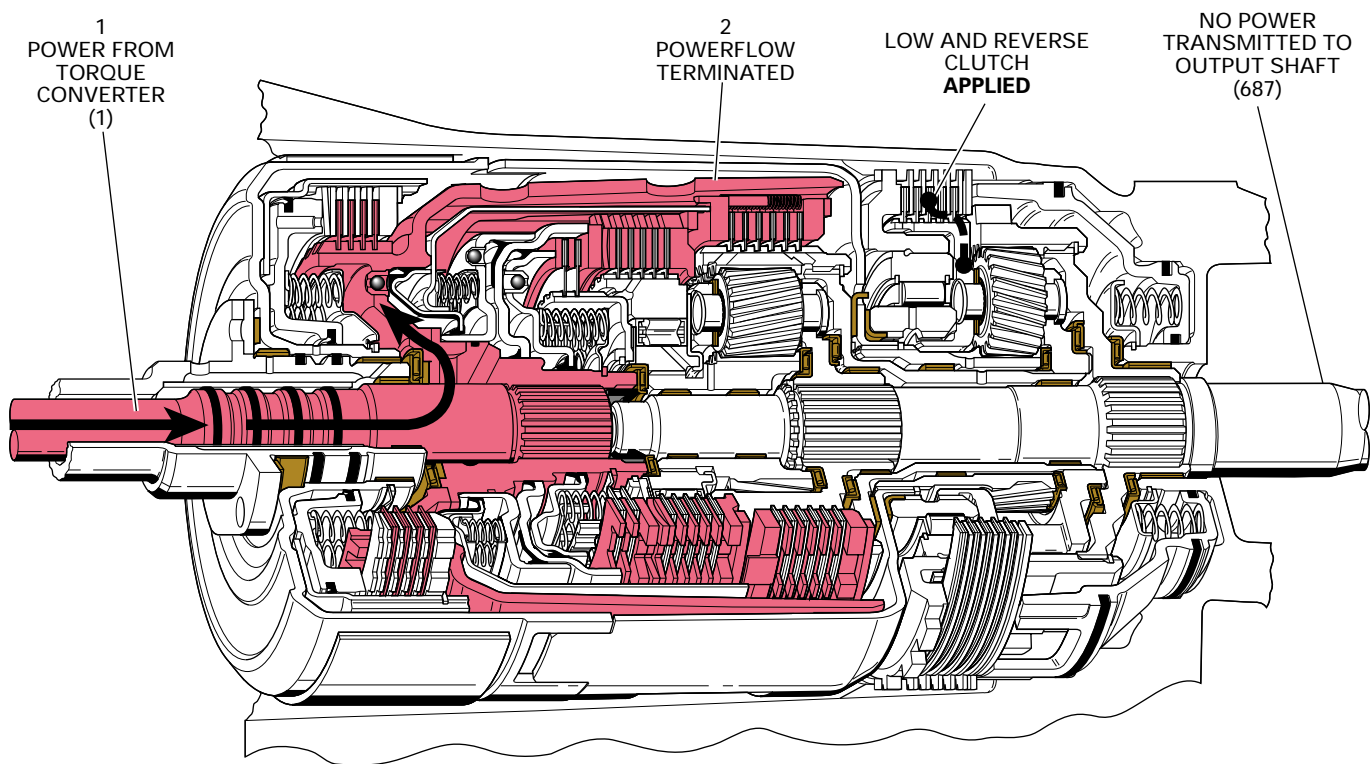

Figure 44

PARK

(Engine Running)



PARK

(Engine Running)

1-2 SHIFT SOLENOID VALVE	2-3 SHIFT SOLENOID VALVE	2-4 BAND	REVERSE INPUT CLUTCH	OVERRUN CLUTCH	FORWARD CLUTCH	FORWARD SPRAG CL ASSEMBLY	3-4 CLUTCH	LO-ROLLER CLUTCH	LO/REV CLUTCH
ON	ON								APPLIED

- The manual shaft (84) and manual valve (340) are in the Park position. The parking lock actuator assembly (85) engages the parking lock pawl (81) with the lugs on the reaction internal gear (684).
- The reaction internal gear is held stationary by the parking pawl.
- The reaction internal gear, which is splined to the output shaft, is also held and the vehicle cannot move.

1 Power from Torque Converter

The turbine shaft, connected to the input housing (621), is driven by the converter turbine.

2 Powerflow Terminated

The input housing contains three separate multiple disc clutches: The overrun clutch, the forward clutch and the 3-4 clutch. All three clutches are released and powerflow is terminated at the input housing.

Low and Reverse Clutch Applied

The low and reverse clutch plates (682) are applied and hold the reaction carrier (681) stationary to the transmission case (8). However, with power flow terminated at the input housing, the low and reverse clutch has no effect on transmission operation in Park.

Note: The vehicle should be completely stopped before selecting Park range or internal damage to the transmission could occur.

Also, the manual linkage must be adjusted properly so the indicator quadrants in the vehicle correspond with the inside detent lever (88) in the transmission. If not adjusted properly, an internal leak between fluid passages at the manual valve may cause a clutch or band to slip or cause the transmission to not hold in Park.

Refer to the appropriate General Motors Service Manual for the proper manual linkage adjustment procedures.

Figure 45

PARK
(Engine Running)

1-2 SHIFT SOLENOID VALVE	2-3 SHIFT SOLENOID VALVE	2-4 BAND	REVERSE INPUT CLUTCH	OVERRUN CLUTCH	FORWARD CLUTCH	FORWARD SPRAG CL. ASSEMBLY	3-4 CLUTCH	LO-ROLLER CLUTCH	LO/REV CLUTCH
ON	ON								APPLIED

FLUID PRESSURE DIRECTED IN PREPARATION FOR A SHIFT

1a Manual Valve:

Mechanically controlled by the gear selector lever, the manual valve is in the Park (P) position and directs line pressure from the pressure regulator valve into the PR fluid circuit.

1b Lo Overrun Valve:

PR fluid is sent from the manual valve to the lo overrun valve where it shifts the valve and enters the low/reverse fluid circuit.

1c Low and Reverse Clutch:

Low/reverse fluid is routed from the lo overrun valve to the low and reverse clutch piston to apply the low and reverse clutch plates.

2 Transmission Fluid Pressure (TFP) Manual Valve Position Switch:

No fluid at the TFP manual valve position switch signals the powertrain control module (PCM) that the transmission is in either Park or Neutral range. The PCM then energizes, or "turns ON" the 1-2 shift solenoid valve and the 2-3 shift solenoid valve.

3 Regulated Apply Valve and Isolator Valve:

Line pressure is routed through the regulated apply valve into the regulated apply fluid circuit. However, because the TCC PWM solenoid valve is not ON, no CC signal fluid is present and orificed regulated apply fluid is able to move the valve enough to open the regulated apply fluid circuit to an exhaust. This prevents any pressure build up in the regulated apply fluid circuit in Park, Reverse, and Neutral.

Note: Refer to Shift Solenoid Valves on page 40 for a description of solenoid and shift valve operation.

PARK
(Engine Running)

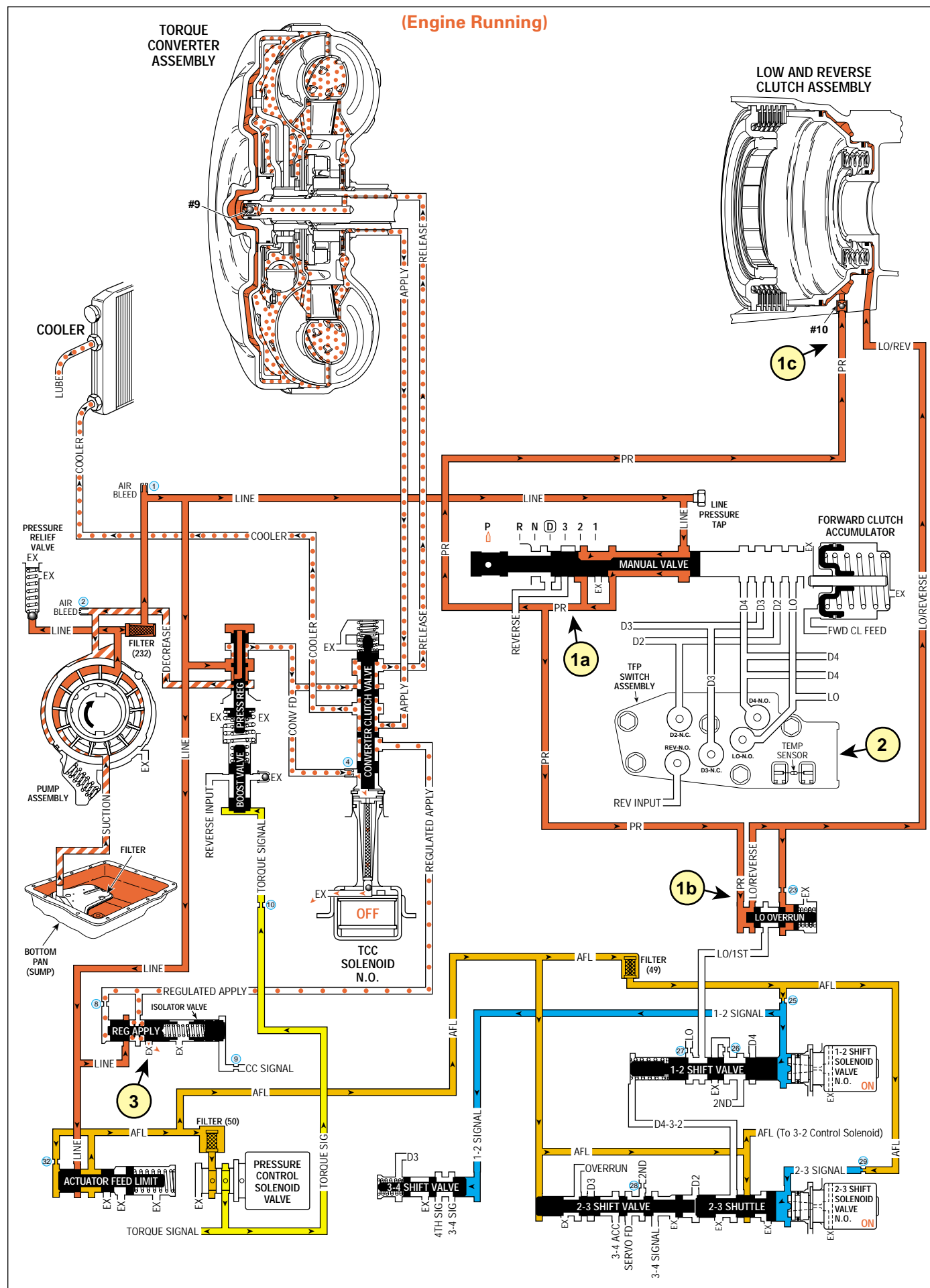
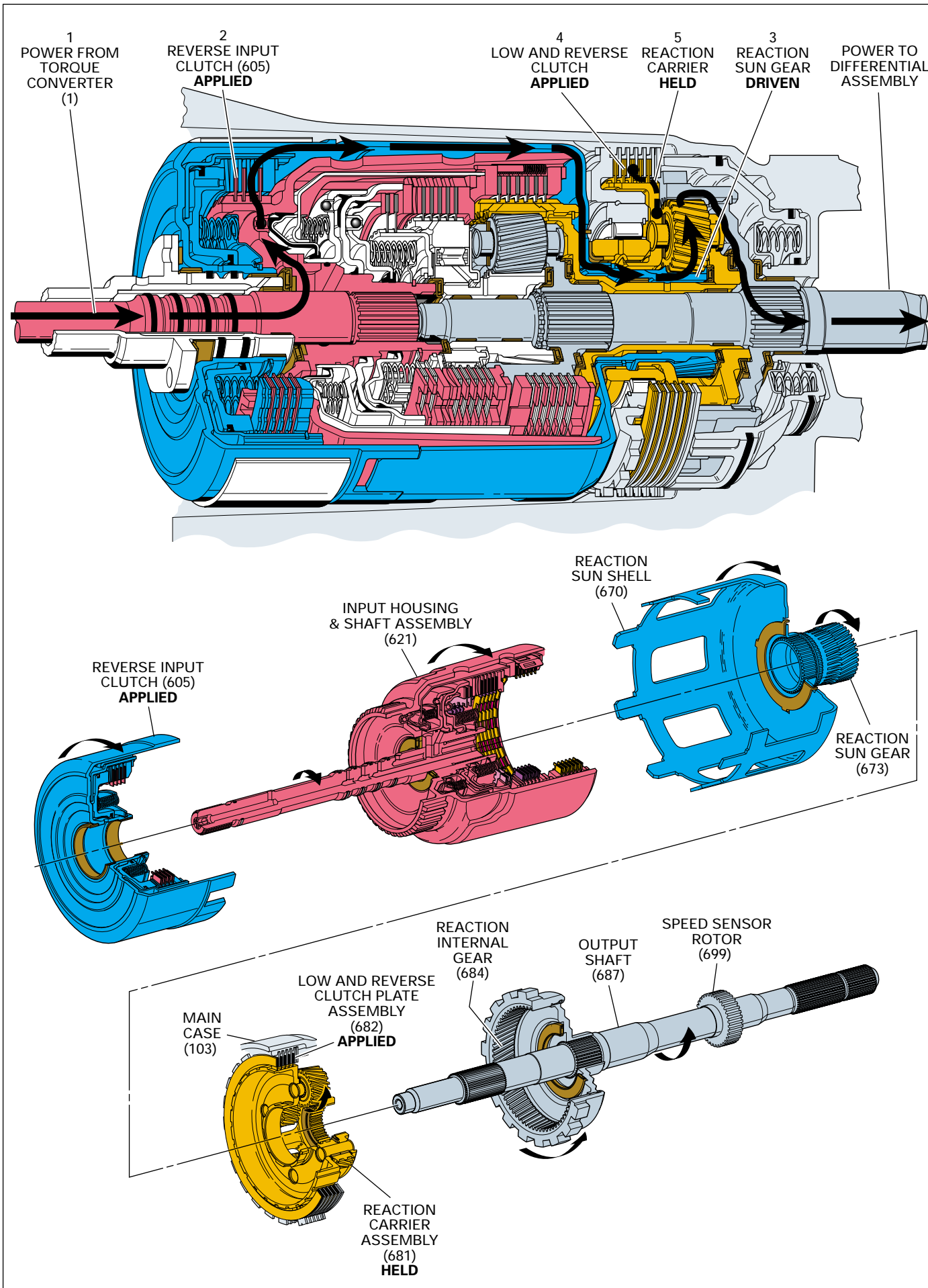

Figure 46

REVERSE

REVERSE

1-2 SHIFT SOLENOID VALVE	2-3 SHIFT SOLENOID VALVE	2-4 BAND	REVERSE INPUT CLUTCH	OVERRUN CLUTCH	FORWARD CLUTCH	FORWARD SPRAG CL. ASSEMBLY	3-4 CLUTCH	LO-ROLLER CLUTCH	LO/REV CLUTCH
ON	ON		APPLIED						APPLIED



In Reverse (R), torque from the engine is multiplied through the torque converter and transmission gear sets to the vehicle's drive shaft and rear axle. The planetary gear sets operate in reduction and also reverse the direction of input torque for a reverse gear ratio of approximately 2.3:1.

- The manual shaft (84) and manual valve (340) are in the Reverse position.

1 Power from Torque Converter

The turbine shaft, connected to the input housing (621), is driven by the converter turbine.

2 Reverse Input Clutch Applied

The reverse input clutch plates (612) are applied and connect the reverse input clutch housing (605) to the input housing. Engine torque is transferred from the input housing, through the clutch plates, and to the reverse input clutch housing. The reverse input clutch housing is connected to the reaction sun shell (670) and torque is transferred to the sun shell.

3 Reaction Sun Gear Driven

The reaction sun gear (673) is splined to the reaction sun shell and is driven clockwise by the sun shell.

4 Low and Reverse Clutch Applied

As in Park range, the low and reverse clutch plates (682) are applied and hold the reaction carrier (681) stationary to the transmission case. This also holds the reaction carrier shaft (666) and input internal gear (664) stationary.

5 Reaction Carrier Held

With the reaction carrier held by the low and reverse clutch, the reaction sun gear drives the reaction carrier pinion gears in a counterclockwise direction. The reaction carrier pinion gears drive the reaction internal gear in a counterclockwise direction. The reaction internal gear is splined to and drives the output shaft (687) counterclockwise to obtain Reverse and a gear reduction of approximately 2.3:1.

- The input carrier assembly (662), splined to the output shaft, also rotates but has no affect in Reverse with all other clutches released.

- When the throttle is released in Reverse, power from vehicle speed is transferred back through the transmission gear train to the engine. This action allows engine compression to slow the vehicle. There is no coast condition in reverse.

REVERSE

1-2 SHIFT SOLENOID VALVE	2-3 SHIFT SOLENOID VALVE	2-4 BAND	REVERSE INPUT CLUTCH	OVERRUN CLUTCH	FORWARD CLUTCH	FORWARD SPRAG CL. ASSEMBLY	3-4 CLUTCH	LO-ROLLER CLUTCH	LO/REV CLUTCH
ON	ON		APPLIED						APPLIED

When the gear selector lever is moved to the Reverse (R) position (from the Park position) the following changes occur in the transmission's hydraulic and electrical systems.

1 PRESSURE REGULATION

1a Manual Valve:

With the manual valve in the reverse position, line pressure is directed into the reverse fluid circuit from the PR fluid circuit already pressurized in Park.

1b Pressure Regulator and Reverse Boost Valves:

Reverse input fluid at the reverse boost valve boosts line pressure for the additional torque requirements in Reverse. Torque signal fluid pressure from the pressure control (PC) solenoid acting on the reverse boost valve also helps determine line pressure in Reverse depending on throttle position and other PCM input signals. Reverse input fluid is also routed through the reverse boost valve and seats the air bleed ball check valve located in the fluid pump.

1c Transmission Fluid Pressure (TFP) Manual Valve Position Switch:

Reverse input fluid is routed to the TFP manual valve position switch. The TFP manual valve position switch signals the PCM that the transmission is in Reverse.

2 LOW AND REVERSE CLUTCH APPLIES

2a #3 Ball Check Valve:

Reverse fluid seats the reverse input ball check valve (#3) and is orificed into the reverse input fluid circuit. This orifice (#17) controls the reverse input clutch apply when engine speed is approximately at idle.

Note: Remember that the function of an orifice is to control the flow rate of fluid and rate of apply or release of a clutch or band.

2b Reverse Abuse Valve:

When engine speed is above idle, reverse fluid acts on the reverse abuse valve to move the valve against spring force. This allows reverse fluid to feed the reverse input fluid circuit quickly, bypassing the control of orifice #17.

2c Reverse Input Clutch:

Reverse input fluid is then routed to the reverse input clutch piston to apply the reverse input clutch plates to obtain reverse gear.

3 FLUID PRESSURE DIRECTED IN PREPARATION FOR A SHIFT

3a 1-2 Shift Solenoid (SS) Valve:

The 1-2 SS valve remains energized (ON). 1-2 signal fluid pressure is high with the 1-2 SS valve energized and keeps the 1-2 shift valve in the downshifted position against spring force. 1-2 signal fluid is also routed to the 3-4 shift valve.

3b 2-3 Shift Solenoid (SS) Valve:

The 2-3 SS valve remains energized (ON). 2-3 signal fluid is high with the 2-3 SS valve energized and keeps the 2-3 shift valve and the 2-3 shuttle valve in the downshifted position.

REVERSE

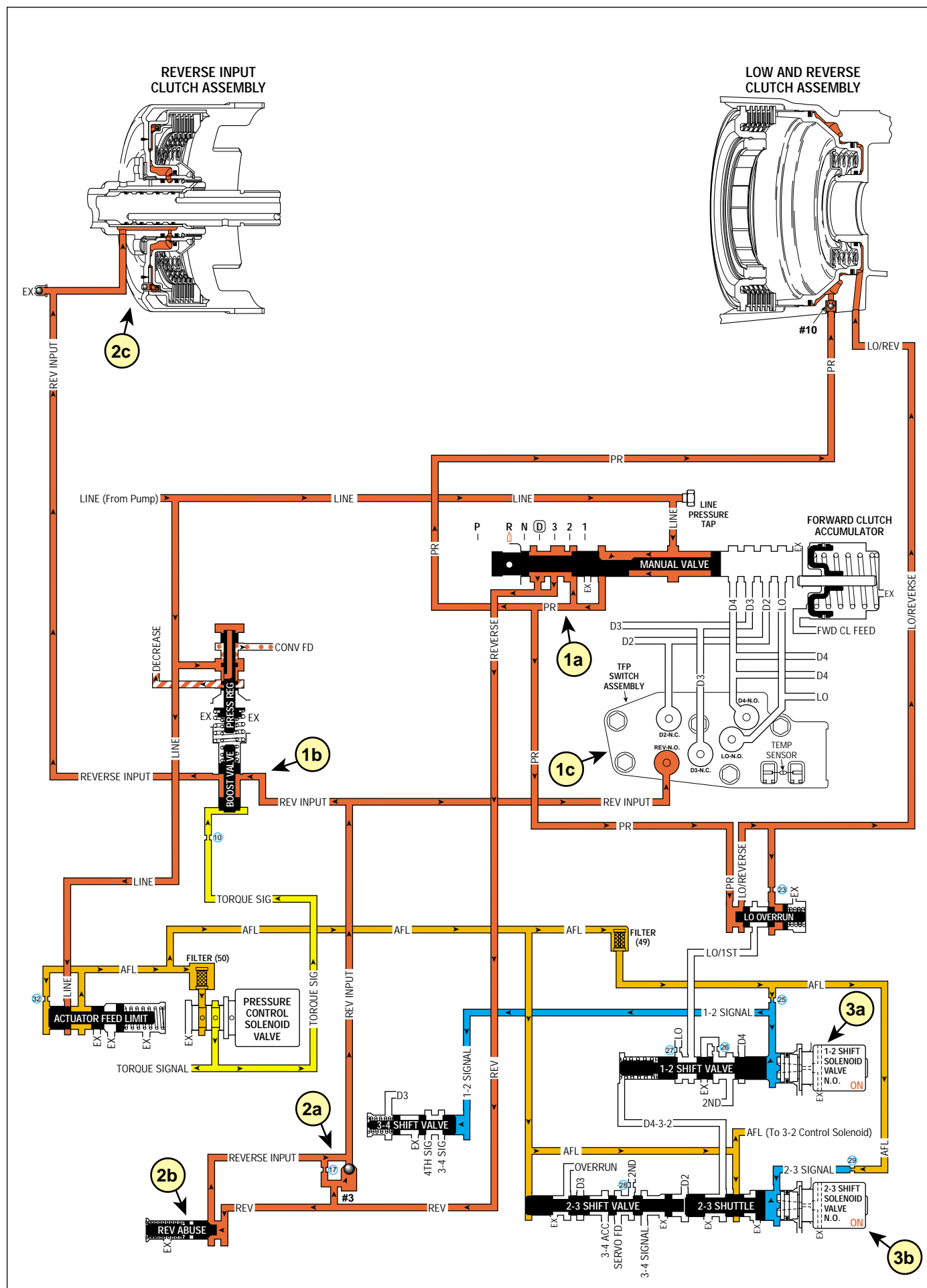
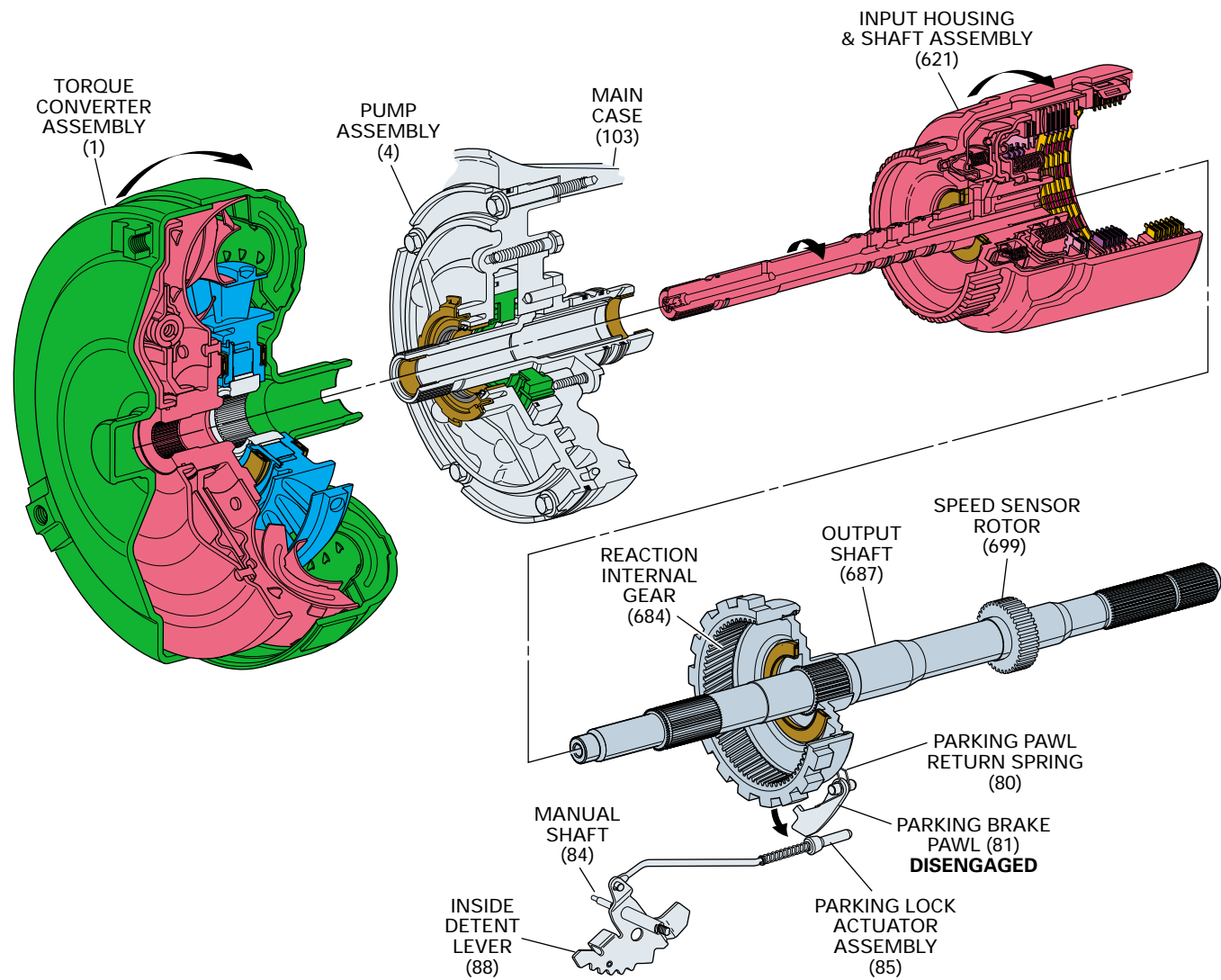
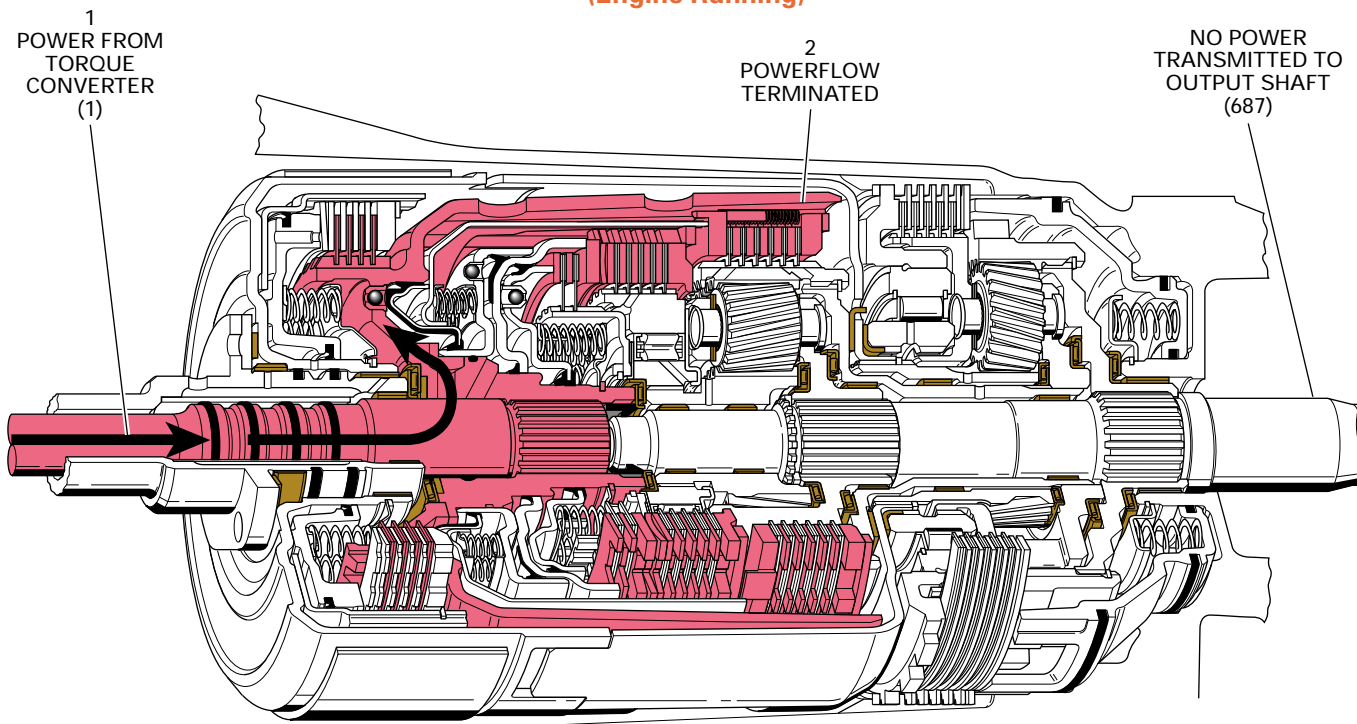

Figure 48

NEUTRAL

(Engine Running)



NEUTRAL

(Engine Running)

1-2 SHIFT SOLENOID VALVE	2-3 SHIFT SOLENOID VALVE	2-4 BAND	REVERSE INPUT CLUTCH	OVERRUN CLUTCH	FORWARD CLUTCH	FORWARD SPRAG CL. ASSEMBLY	3-4 CLUTCH	LO-ROLLER CLUTCH	LO/REV CLUTCH
ON	ON								

When the gear selector lever is placed in the Neutral (N) position, mechanical power flow is identical to Park (P) range, except that the parking lock actuator assembly (85) is disengaged. The parking pawl return spring (80) releases the parking lock pawl (81) from the lugs on the reaction internal gear (684). With the parking lock pawl disengaged the output shaft is free to rotate, allowing the vehicle to roll.

- The manual shaft (84) and manual valve (340) are in the Neutral position.

1 Power from Torque Converter

The turbine shaft, connected to the input housing (621), is driven by the converter turbine.

2 Powerflow Terminated

The input housing contains three separate multiple disc clutches: The overrun clutch, the forward clutch and the 3-4 clutch. All three clutches are released and powerflow is terminated at the input housing.

Neutral range may be selected for starting the engine when the vehicle is standing still or moving down the road.

NEUTRAL (Engine Running)

1-2 SHIFT SOLENOID VALVE	2-3 SHIFT SOLENOID VALVE	2-4 BAND	REVERSE INPUT CLUTCH	OVERRUN CLUTCH	FORWARD CLUTCH	FORWARD SPRAG CL. ASSEMBLY	3-4 CLUTCH	LO-ROLLER CLUTCH	LO/REV CLUTCH
ON	ON								

When the gear selector lever is moved to the Neutral (N) position, the manual valve also moves and blocks line pressure from entering any other fluid circuits. If Neutral is selected after the vehicle was operating in Reverse (R), the following changes would occur in the hydraulic and electrical systems:

1 REVERSE INPUT CLUTCH RELEASES

1a Manual Valve:

The manual valve is moved to the Neutral position and blocks line pressure from entering the PR and reverse circuits. The PR and reverse fluid circuits are opened to an exhaust at the manual valve.

1b Reverse Abuse Valve:

Exhausting reverse fluid pressure allows the reverse abuse valve spring to shift the valve, blocking off the reverse input fluid circuit.

1c Reverse Input Clutch:

Reverse input fluid pressure, which was fed by reverse fluid, exhausts from the reverse input clutch piston allowing the reverse input clutch to release.

1d Reverse Boost Valve:

Reverse input fluid exhausts from the reverse boost valve, allowing line pressure to return to the normal operating range as in Park, Neutral and Overdrive gear ranges.

1e Reverse Input Ball Check Valve (#3):

Exhausting reverse input fluid unseats the #3 ball check valve, allowing reverse input fluid to exhaust quickly into the reverse fluid circuit.

1f Transmission Fluid Pressure (TFP) Manual Valve Position Switch:

Reverse input fluid also exhausts from the TFP manual valve position switch signaling the powertrain control module (PCM) that the transmission is in either Neutral (N) or Park (P).

2 LOW AND REVERSE CLUTCH RELEASES

2a Lo Overrun Valve:

Exhausting PR fluid pressure allows the lo overrun valve spring to shift the valve, opening up the lo/reverse fluid circuit to exhaust into the lo/1st fluid circuit.

2b Low and Reverse Clutch:

PR fluid exhausts from the outer area of the low and reverse clutch piston. Exhausting PR fluid unseats the low and reverse clutch ball check valve (#10) for a quick exhaust. Lo/Reverse fluid pressure, which was fed by PR fluid, exhausts from the inner area of the low and reverse clutch piston and passes through the lo overrun valve into the lo/1st fluid circuit.

2c 1-2 Shift Valve:

Exhausting lo/reverse fluid, in the lo/1st circuit, enters the lo fluid circuit at the 1-2 shift valve and exhausts at the manual valve.

Note: Allowing fluid to bypass an orifice when exhausting ensures a quick release of the clutch or band. This prevents the friction material from "dragging" and creating excess fluid temperatures or damaging the clutch or band.

Note: In Park, Reverse and Neutral the shift solenoids are shown in the First gear state. This is the normal operating state when the vehicle is stationary or at low vehicle speeds. However, the PCM will change the shift solenoid states depending on vehicle speed. For example, if Neutral range is selected when the vehicle is operating in Second gear, the shift solenoids will remain in a Second gear state. But with the manual valve in Neutral, line pressure is blocked, D4 fluid exhausts and the transmission will shift into Neutral.

NEUTRAL (Engine Running)

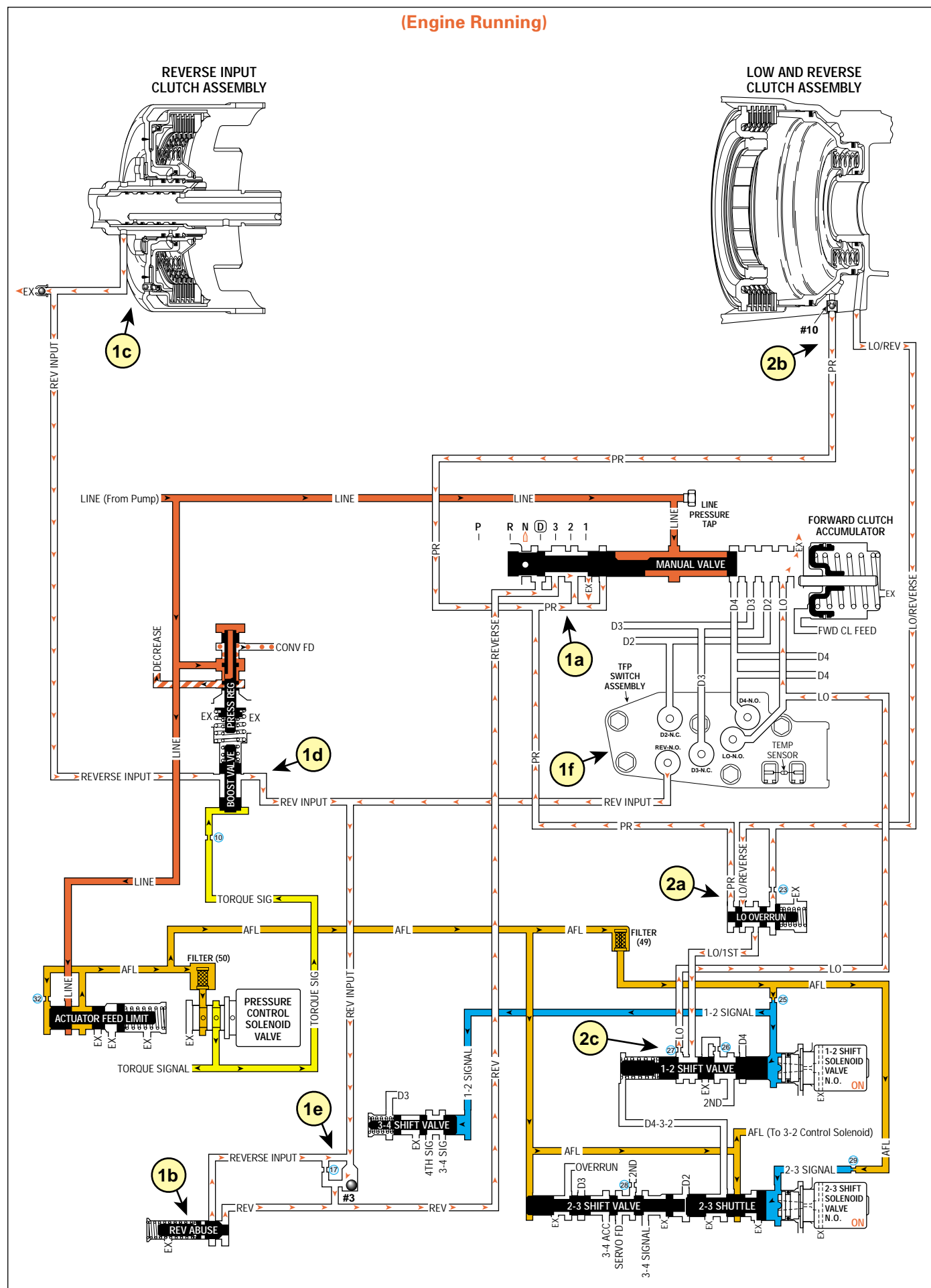
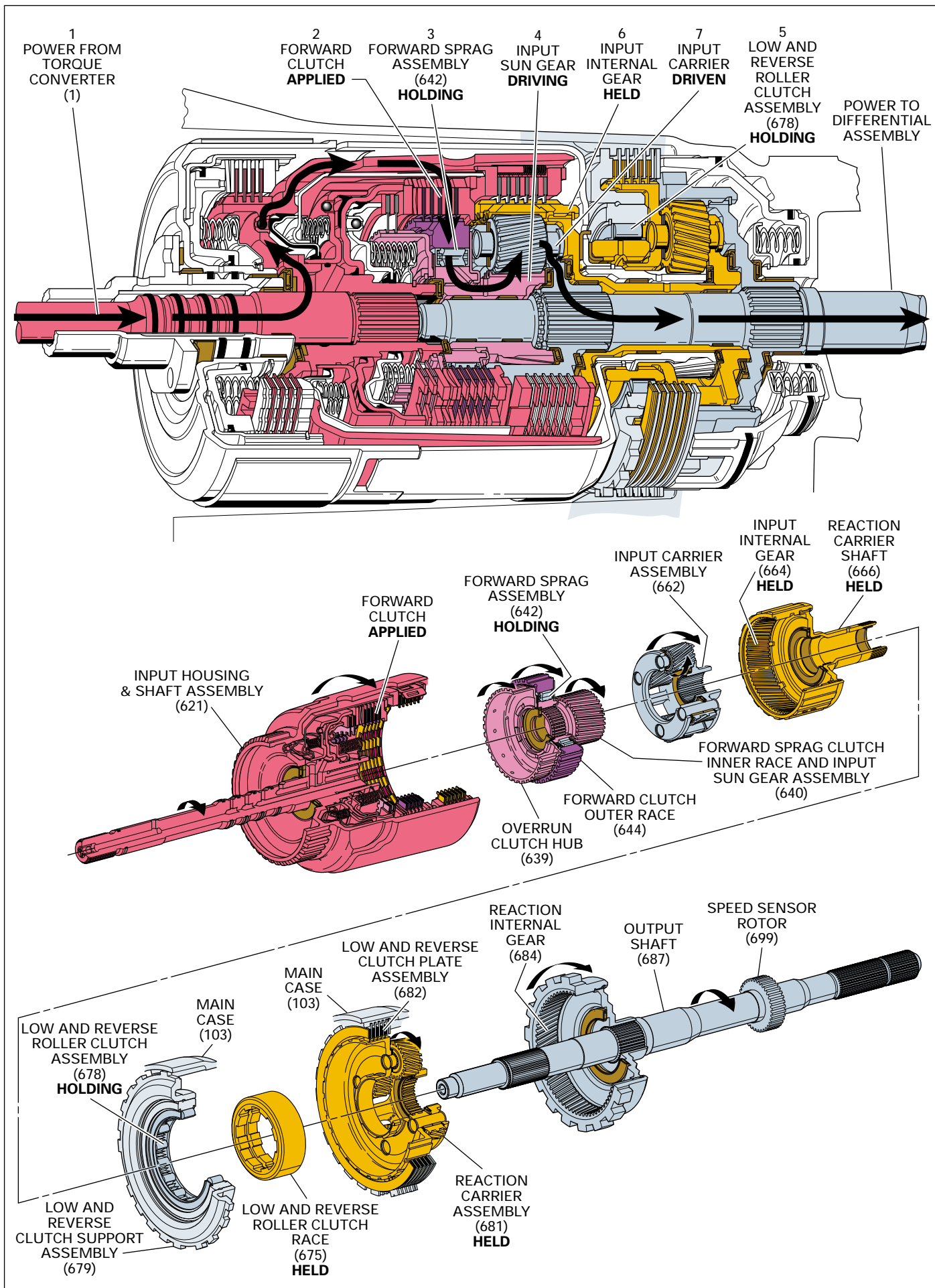

Figure 50

OVERDRIVE RANGE – FIRST GEAR



OVERDRIVE RANGE – FIRST GEAR

1-2 SHIFT SOLENOID VALVE	2-3 SHIFT SOLENOID VALVE	2-4 BAND	REVERSE INPUT CLUTCH	OVERRUN CLUTCH	FORWARD CLUTCH	FORWARD SPRAG CL. ASSEMBLY	3-4 CLUTCH	LO-ROLLER CLUTCH	LO/REV CLUTCH
ON	ON				APPLIED	HOLDING		HOLDING	

In Overdrive Range – First Gear, torque from the engine is multiplied through the torque converter and transmission gear sets to the vehicle's drive shaft. The planetary gears operate in reduction to achieve a First gear starting ratio of approximately 3.06:1.

- The manual shaft (84) and manual valve (340) are in the Overdrive **D** position.

1 Power from Torque Converter

The turbine shaft, connected to the input housing (621), is driven by the converter turbine.

2 Forward Clutch Applied

The forward clutch is applied in all forward gear ranges. The forward clutch plates (649) transfer engine torque from the input housing to the forward clutch outer race (644).

3 Forward Sprag Assembly Holding

The sprag clutch (642), located between the forward clutch outer race and the forward sprag inner race and input sun gear assembly (640), locks and drives the forward sprag inner race and input sun gear assembly.

4 Input Sun Gear Driving

The input sun gear drives the input carrier pinion gears counterclockwise.

5 Low and Reverse Roller Clutch Assembly Holding

The low and reverse roller clutch (678) is located between the low and reverse clutch support assembly (679) (which is splined to the case) and the reaction carrier assembly. With the reaction carrier attempting to rotate counterclockwise, the roller clutch locks and prevents the reaction carrier, reaction carrier shaft and input internal gear from rotating.

6 Input Internal Gear Held

The input carrier pinion gears, rotating counterclockwise on their pins, walk clockwise around the stationary input internal gear. This action drives the input carrier assembly (662) clockwise.

7 Input Carrier Driven

The input carrier assembly is splined to and drives the output shaft (687) in a First gear reduction of approximately 3.06:1.

- As a result of the output shaft rotating, the reaction internal gear (684), reaction carrier pinion gears, reaction sun gear (673), reaction sun shell (670), and reverse input clutch housing (605) all rotate but do not affect the transmission's mechanical power flow.

Coast Conditions

- When the throttle is released in Overdrive Range – First Gear and engine RPM decreases, power from vehicle speed drives the output shaft and input carrier (662) faster than engine torque is driving the forward clutch outer race (644). This allows the input carrier pinion gears to drive the forward sprag inner race and input sun gear assembly (640) clockwise faster than the forward clutch outer race. This causes the forward sprag inner race and input sun gear assembly to overrun the sprag clutch and allow the vehicle to coast freely without engine compression slowing the vehicle.
- Also during coast conditions, the reaction internal gear drives the reaction carrier pinion gears. This drives the reaction carrier clockwise and overruns the low and reverse roller clutch.

As vehicle speed increases, less torque multiplication is needed for maximum efficiency. Therefore, it is desirable to shift the transmission to a lower gear ratio, or Second gear.

Figure 51

OVERDRIVE RANGE – FIRST GEAR

1-2 SHIFT SOLENOID VALVE	2-3 SHIFT SOLENOID VALVE	2-4 BAND	REVERSE INPUT CLUTCH	OVERDRIVE CLUTCH	FORWARD CLUTCH	FORWARD SPRAG CL. ASSEMBLY	3-4 CLUTCH	LO-ROLLER CLUTCH	LO/REV CLUTCH
ON	ON				APPLIED	HOLDING		HOLDING	

When the gear selector lever is moved to the Overdrive Range (D) position from the Neutral (N) position, the following changes occur to shift the transmission into Overdrive Range – First Gear.

1 OVERDRIVE RANGE

1a Manual Valve:

In the Overdrive position the manual valve routes line pressure into the D4 fluid circuit.

1b Transmission Fluid Pressure (TFP) Manual Valve Position Switch:

D4 fluid is routed to the TFP manual valve position switch to signal the powertrain control module (PCM) that the transmission is in Overdrive Range (D).

1c Rear Lube:

D4 fluid is also routed to the rear of the transmission case where it is orificed (#24) into the rear lube fluid circuit to lubricate the rear end of the transmission.

2 FORWARD CLUTCH APPLIES

2a Forward Clutch Accumulator Ball Check Valve (#12):

D4 fluid pressure seats the forward clutch accumulator ball check valve (#12) and is orificed into the forward clutch feed fluid circuit. This orifice (#22) helps control the forward clutch apply when engine speed is approximately at idle.

2b Forward Abuse Valve:

When engine speed is above idle, D4 fluid acts on the forward abuse valve to move the valve against spring force. This allows D4 fluid to feed the forward clutch feed fluid circuit quickly, bypassing the control of orifice #22.

2c Forward Clutch Assembly:

Forward clutch feed fluid is routed to the forward clutch piston to apply the forward clutch plates and obtain a First gear ratio through the transmission gear sets.

2d Forward Clutch Accumulator:

As the forward clutch applies, forward clutch feed fluid pressure moves the forward clutch accumulator piston against spring force. This action absorbs some of the initial increase of forward clutch feed fluid pressure to cushion the forward clutch apply.

3 SHIFT ACCUMULATION

3a Accumulator Valve:

D4 fluid is also directed to the accumulator valve where it is regulated into accumulator fluid pressure in response to torque signal fluid pressure, orificed accumulator fluid pressure and accumulator valve spring force.

3b 1-2 Accumulator:

Accumulator fluid is routed to and fills the 1-2 accumulator in preparation for a 1-2 upshift.

3c 3-4 Accumulator:

Accumulator fluid also seats the #1 ball check valve, is forced through orifice #18 into the orificed accumulator fluid circuit and fills the 3-4 accumulator with fluid in preparation for a 3-4 upshift.

4 FLUID PRESSURE DIRECTED IN PREPARATION FOR A SHIFT

4a 1-2 Shift Valve:

D4 fluid is routed to the 1-2 shift valve in preparation for an upshift to second gear.

5 FLUID PRESSURE DIRECTED IN PREPARATION FOR TCC APPLY

5a TCC PWM Solenoid Valve:

The solenoid duty cycle regulates actuator feed limit fluid (AFL) into the CC signal circuit.

5b Regulated Apply Valve and Isolator Valve:

CC signal fluid works together with orificed regulated apply fluid to regulate line pressure through the regulated apply valve, into the regulated apply fluid circuit.

5c TCC Solenoid Valve:

Regulated apply fluid is routed to the converter clutch valve in preparation for TCC apply.

OVERDRIVE RANGE – FIRST GEAR

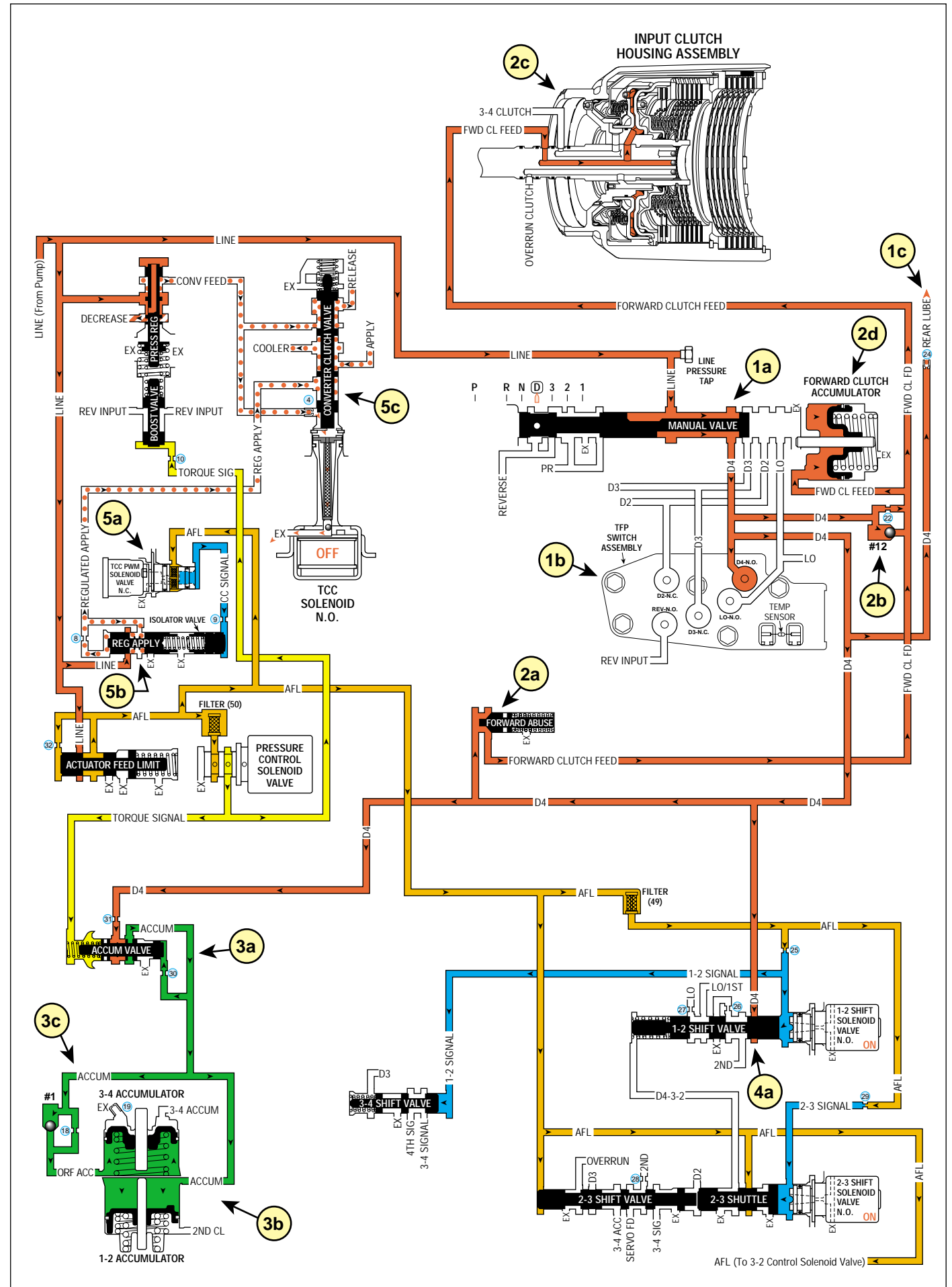

OVERDRIVE RANGE – SECOND GEAR

OVERDRIVE RANGE – SECOND GEAR

1-2 SHIFT SOLENOID VALVE	2-3 SHIFT SOLENOID VALVE	2-4 BAND	REVERSE INPUT CLUTCH	OVERRUN CLUTCH	FORWARD CLUTCH	FORWARD SPRAG CL. ASSEMBLY	3-4 CLUTCH	LO-ROLLER CLUTCH	LO/REV CLUTCH
OFF	ON	APPLIED			APPLIED	HOLDING			

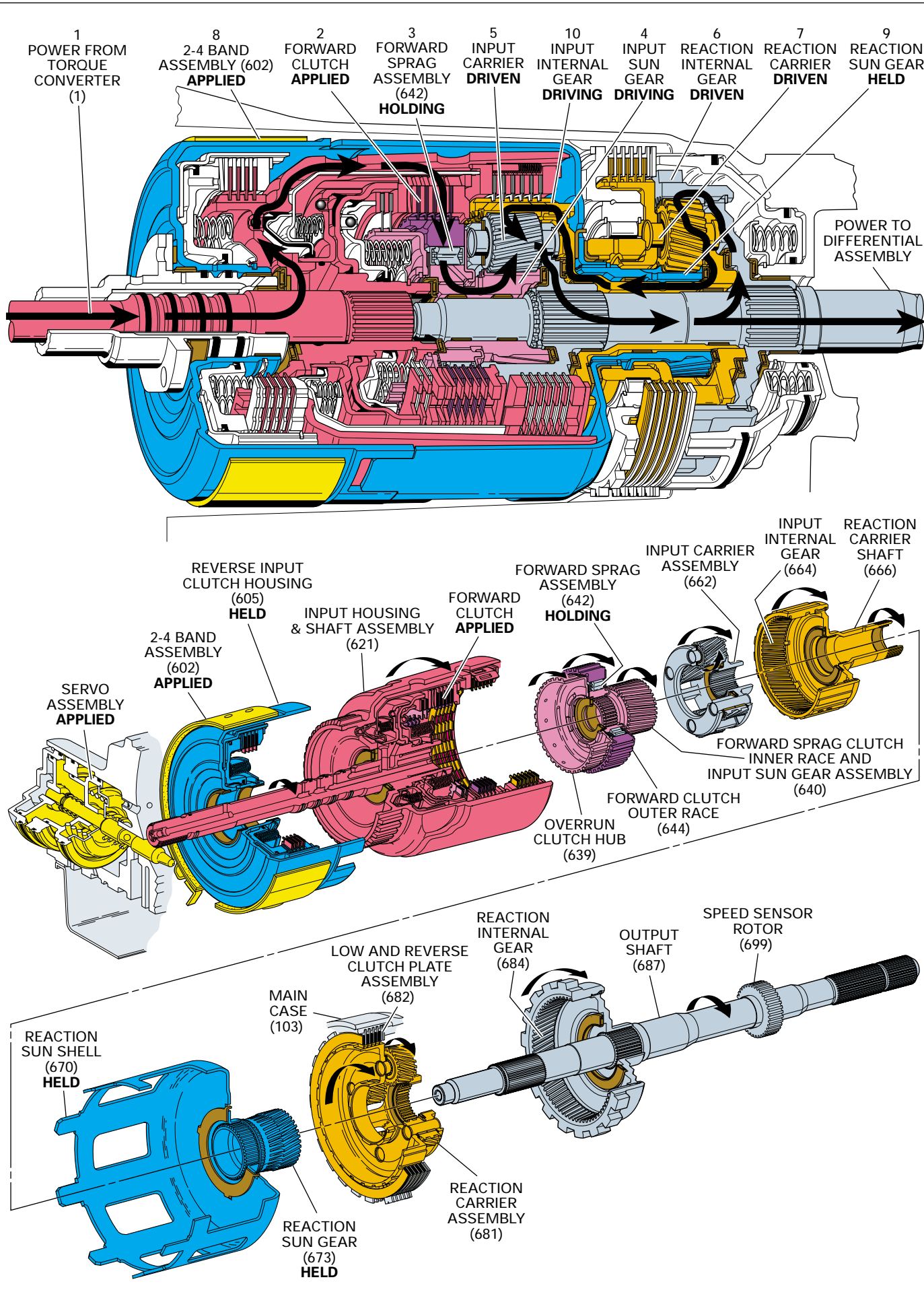

As vehicle speed increases, input signals from the transmission speed sensor, the throttle position (TP) sensor, and other vehicle sensors are sent to the powertrain control module (PCM). The PCM processes this information to determine the precise moment to shift the transmission. In Second gear, the planetary gear sets continue to operate in reduction at a gear ratio of approximately 1.63:1.

- 1 Power from Torque Converter**
The turbine shaft, connected to the input housing (621), is driven by the converter turbine.
- 2 Forward Clutch Applied**
The forward clutch (649) is applied and the forward clutch plates (649) transfer engine torque from the input housing to the forward clutch outer race (644).
- 3 Forward Sprag Clutch Holding**
The forward sprag clutch assembly locks and drives the forward sprag clutch inner race and input sun gear assembly (640).
- 4 Input Sun Gear Driving**
The forward sprag clutch inner race and input sun gear assembly (640) drives the input carrier pinion gears.
- 5 Input Carrier Driven**
The input carrier assembly (662) is driven clockwise by the input carrier pinion gears walking around the input internal gear (664) as in First gear. This action drives the output shaft (687) and the reaction internal gear (684).
- 6 Reaction Internal Driven**
The reaction internal gear rotates with the output shaft and drives the reaction carrier pinion gears in a clockwise direction.
- 7 Reaction Carrier Driven**
The reaction carrier shaft (666) and input internal gear (664) are driven clockwise by the reaction carrier assembly.
- 8 2-4 Band Assembly Applied**
The 2-4 band (602) is applied and holds the reverse input clutch housing (605) stationary to the transmission case.
- 9 Reaction Sun Gear Held**
The reverse input clutch housing and the reaction sun gear (673) are splined to the reaction sun shell (670). With the 2-4 band applied, the sun shell and reaction sun gear are also held stationary.
- 10 Input Internal Gear Driving**
The input internal gear drives the input carrier pinions, input carrier and output shaft in a second reduction to achieve the Second gear ratio of approximately 1.63:1.

Coast Conditions

- Similar to Overdrive Range – First Gear, the forward sprag clutch is overrun when the throttle is released. This action allows the vehicle to coast freely in Overdrive Range – Second Gear.

As vehicle speed increases, less torque multiplication is needed to move the vehicle efficiently. Therefore, it is desirable to shift the transmission to a lower gear ratio, or Third gear.

OVERDRIVE RANGE – SECOND GEAR

1-2 SHIFT SOLENOID VALVE	2-3 SHIFT SOLENOID VALVE	2-4 BAND	REVERSE INPUT CLUTCH	OVERRUN CLUTCH	FORWARD CLUTCH	FORWARD SPRAG CL. ASSEMBLY	3-4 CLUTCH	LO-ROLLER CLUTCH	LO/REV CLUTCH
OFF	ON	APPLIED			APPLIED	HOLDING			

As vehicle speed increases, the powertrain control module (PCM) receives input signals from the vehicle speed sensor, the throttle position (TP) sensor and other vehicle sensors to determine the precise moment to de-energize or “turn OFF” the 1-2 shift solenoid (SS) valve. The 1-2 SS valve is OFF when the PCM eliminates the path to ground for that circuit.

1 2-4 BAND APPLIES

1a 1-2 Shift Solenoid (SS) Valve:

The 1-2 SS valve is de-energized, allowing 1-2 signal fluid to exhaust from its circuit.

1b 1-2 Shift Valve:

Exhausting 1-2 signal fluid pressure allows 1-2 shift valve spring force to move the 1-2 shift valve into the upshifted position. D4 fluid is routed through the 1-2 shift valve and into the 2nd fluid circuit.

1c #8 Ball Check Valve:

2nd fluid seats the #8 ball check valve, passes through an orifice (#16) and enters the 2nd clutch fluid circuit.

1d 2nd & 4th Servo:

2nd clutch fluid is directed to the 2nd & 4th servo to move the 2nd apply piston against servo cushion and servo return spring forces to apply the 2-4 band and achieve Second gear.

2 SHIFT ACCUMULATION

2a 1-2 Accumulator:

2nd clutch fluid is also sent to the 1-2 accumulator. 2nd clutch fluid pressure, together with spring pressure, acts against accumulator fluid pressure to absorb some of the initial increase of 2nd clutch fluid pressure to cushion the 2-4 band apply.

2b Accumulator Valve:

Accumulator fluid is forced out of the 1-2 accumulator when 2nd clutch fluid pressure and spring force move the 1-2 accumulator piston. Accumulator fluid flows back to the accumulator valve and into the orificed accumulator fluid circuits. Orificed accumulator fluid pressure and accumulator spring force regulate the accumulator valve against torque signal fluid pressure. This allows excess accumulator fluid pressure to exhaust and provides additional control of the 2-4 band apply.

3 FLUID PRESSURE DIRECTED IN PREPARATION FOR A SHIFT

3a 2-3 Shift Valve:

2nd fluid is directed to the 2-3 shift valve in preparation for an upshift to third gear. 2nd fluid also passes through the 2-3 shift valve into the servo feed fluid circuit and is directed to the 3-4 relay and 4-3 sequence valves where it stops. Servo feed fluid has no function in second gear.

3b 3-4 Relay Valve:

2nd fluid pressure is also directed to the 3-4 relay valve in preparation for an upshift.

3c 3-2 Downshift Valve:

Spring force holds the valve closed, blocking 2nd fluid pressure and 2nd clutch fluid pressure. This valve is used in order to help control a 3-2 downshift.

3d 3-2 Control Solenoid Valve:

In second gear, the PCM energizes the normally closed solenoid. This opens the actuator feed limit fluid circuit to fill the 3-2 signal circuit. The 3-2 signal fluid pressure moves the 3-2 control valve against spring force. This action is done in preparation for control of a 3-2 downshift and does not affect transmission operation in second gear.

OVERDRIVE RANGE – SECOND GEAR

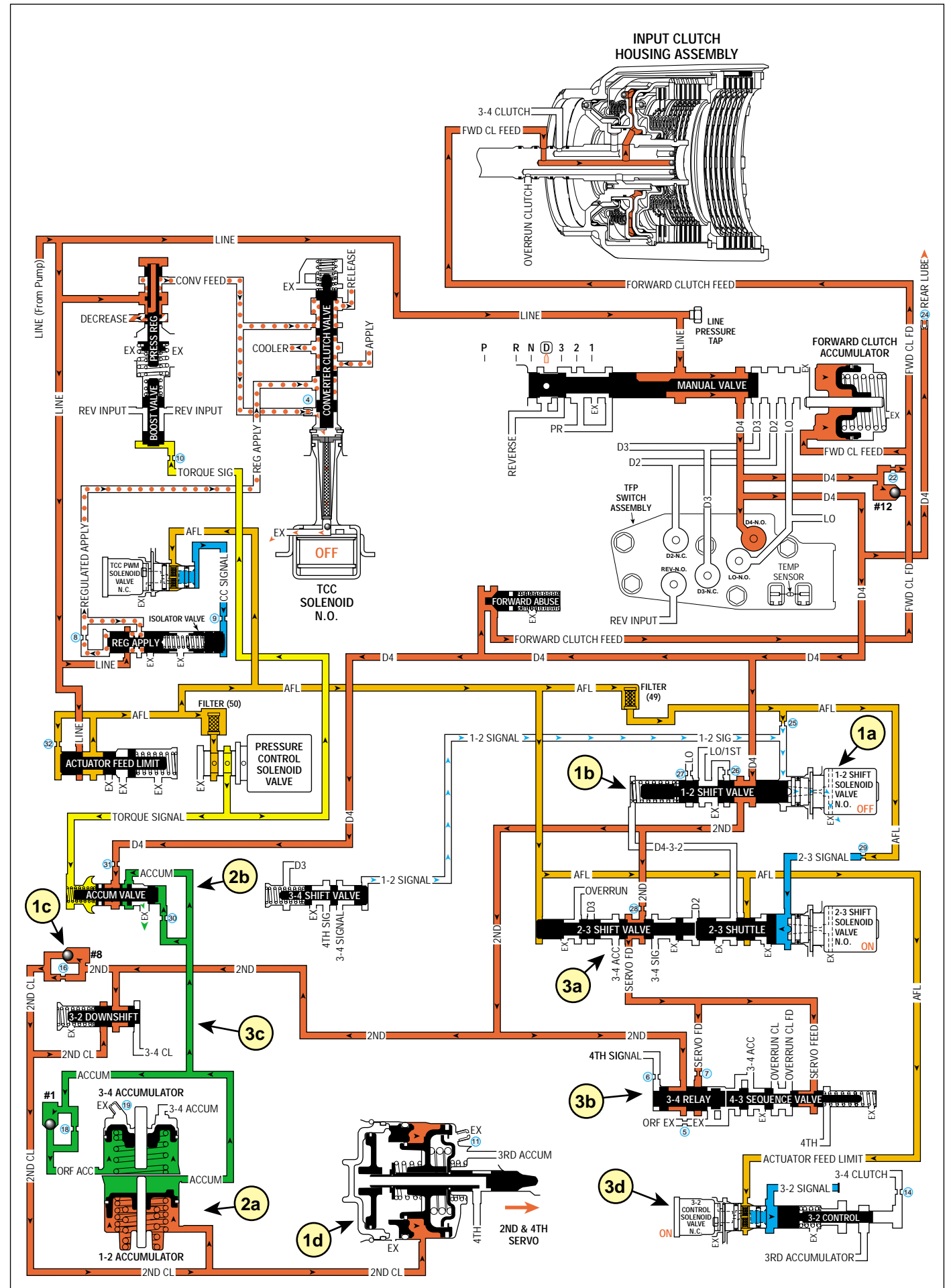
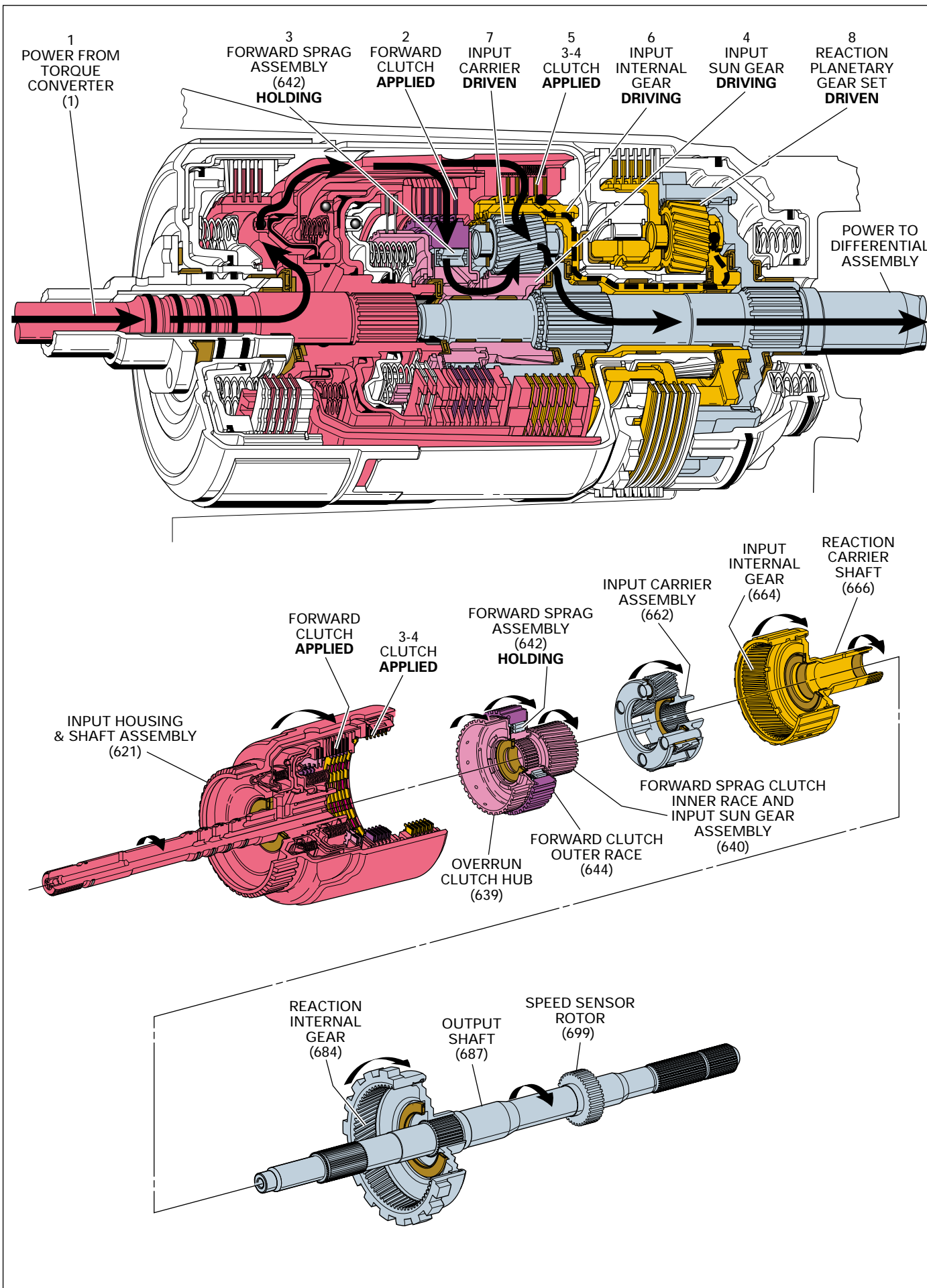

Figure 54

OVERDRIVE RANGE – THIRD GEAR



OVERDRIVE RANGE – THIRD GEAR

1-2 SHIFT SOLENOID VALVE	2-3 SHIFT SOLENOID VALVE	2-4 BAND	REVERSE INPUT CLUTCH	OVERRUN CLUTCH	FORWARD CLUTCH	FORWARD SPRAG CL. ASSEMBLY	3-4 CLUTCH	LO-ROLLER CLUTCH	LO/REV CLUTCH
OFF	OFF				APPLIED	HOLDING	APPLIED		

As vehicle speed increases further, input signals from the transmission speed sensor, the throttle position (TP) sensor, and other vehicle sensors are sent to the PCM. The PCM uses this information to determine the precise moment to shift the transmission into Third gear. In Third gear, both planetary gear sets, input and reaction, rotate at the same speed and provide a 1:1 direct drive gear ratio between the converter turbine and the output shaft.

- 1 Power from Torque Converter**
The turbine shaft, connected to the input housing (621), is driven by the converter turbine.
- 2 Forward Clutch Applied**
The forward clutch (649) is applied and the forward clutch plates (649) transfer engine torque from the input housing to the forward clutch outer race (644).
- 3 Forward Sprag Clutch Holding**
The forward sprag clutch assembly locks and drives the forward sprag clutch inner race and input sun gear assembly (640).
- 4 Input Sun Gear Driving**
The forward sprag clutch inner race and input sun gear assembly (640) drives the input carrier pinion gears.
- 5 3-4 Clutch Applied**
The 3-4 clutch plates (654) are applied and transfer engine torque from the input housing (621) to the input internal gear (664).
- 6 Input Internal Gear Driving**
Both the input internal gear and the input sun gear are driven at the same speed. The input carrier pinion gears are splined to these components and act as wedges to drive the input carrier assembly (662).
- 7 Input Carrier Driven**
The input carrier drives the output shaft (687) at converter turbine speed to achieve direct drive in Third gear.
- 8 Reaction Planetary Gearset Driven**
The reaction internal gear (684) is driven by the output shaft. Also, the reaction carrier shaft (666) is driven by the input planetary gear set and drives the reaction carrier assembly (681). With the reaction carrier and reaction internal gear rotating at the same speed, the pinion gears act as wedges and drive the reaction sun gear (673) at the same speed. As a result, the entire gear set rotates as one unit at converter turbine speed.

Coast Conditions

- As in First and Second gears when the throttle is released, power from vehicle speed drives the forward sprag clutch inner race and input sun gear assembly (640) faster than engine torque drives the forward clutch outer race (644). This action causes the forward sprag clutch inner race and input sun gear assembly (640) to overrun the sprag clutch (642) and allow the vehicle to coast freely.

As vehicle speed increases, less torque multiplication is required to operate the engine efficiently. Therefore, it is desirable to shift to an overdrive gear ratio, or Fourth gear.

OVERDRIVE RANGE – THIRD GEAR

1-2 SHIFT SOLENOID VALVE	2-3 SHIFT SOLENOID VALVE	2-4 BAND	REVERSE INPUT CLUTCH	OVERRUN CLUTCH	FORWARD CLUTCH	FORWARD SPRAG CL. ASSEMBLY	3-4 CLUTCH	LO-ROLLER CLUTCH	LO/REV CLUTCH
OFF	OFF				APPLIED	HOLDING	APPLIED		

As vehicle speed increases, the PCM receives input signals from the vehicle speed sensor, the TP sensor and other vehicle sensors to determine the precise moment to de-energize or “turn OFF” the 2-3 shift solenoid (SS) valve.

1 2-4 BAND RELEASES

1a 2-3 Shift Solenoid (SS) Valve:

The 2-3 SS valve is de-energized, allowing 2-3 signal fluid to exhaust from its circuit.

1b 2-3 Shift Valve and 2-3 Shuttle Valve:

Exhausting 2-3 signal fluid pressure allows AFL fluid pressure to move the 2-3 shift valve and the 2-3 shuttle valve into the upshifted position. Orificed (#28) 2nd fluid is directed into the 3-4 signal fluid circuit. Also, AFL fluid pressure fills the D432 fluid circuit.

1c #4 and #2 Ball Check Valves:

3-4 signal fluid unseats the 3-4 clutch exhaust ball check valve (#4) and enters the 3-4 clutch fluid circuit. 3-4 clutch fluid unseats the 3rd accumulator ball check valve (#2) and enters the 3rd accumulator fluid circuit.

1d 2nd & 4th Servo:

3rd accumulator fluid seats the 3rd accumulator exhaust ball check valve (#7) and enters the 2nd & 4th servo. 3rd accumulator fluid pressure assists servo return spring force to move the 2nd apply piston and apply pin against 2nd clutch fluid pressure. This action releases the 2-4 band.

1e 3-4 Relay Valve and 4-3 Sequence Valve:

Servo feed fluid is allowed to exhaust past the 3-4 relay and 4-3 sequence valves and through an orificed exhaust (#5).

2 3-4 CLUTCH APPLIES

2a 3-4 Clutch:

3-4 clutch fluid is directed to the 3-4 clutch piston to apply the 3-4 clutch plates and obtain Third gear.

2b 1-2 Shift Valve:

D432 fluid pressure from the 2-3 shift valve assists spring force to hold the 1-2 shift valve in the upshifted position.

3 SHIFT ACCUMULATION

3a 2nd & 4th Servo:

With 3-4 clutch fluid feeding the 3rd accumulator fluid circuit, the movement of the 2nd apply piston in the 2nd & 4th servo acts as an accumulator by absorbing initial 3-4 clutch fluid to cushion the 3-4 clutch apply.

3b 1-2 Accumulator:

The movement of the 2nd apply piston in the 2nd & 4th servo also forces 2nd clutch fluid out of the servo and sends it to the 1-2 accumulator to further cushion the 3-4 clutch apply.

4 TORQUE CONVERTER CLUTCH RELEASED

4a TCC Solenoid Valve:

Under normal operating conditions, in Overdrive Range – Third Gear, the PCM keeps the normally open TCC solenoid valve de-energized. Converter feed fluid exhausts through the solenoid, and spring force keeps the converter clutch valve in the release position. However, at speeds above approximately 121 km/h (75 mph) the PCM will command TCC apply in third gear. Refer to pages 62–63 for more information on TCC apply.

5 FLUID PRESSURE DIRECTED IN PREPARATION FOR A SHIFT

5a 3-4 Shift Valve:

3-4 signal fluid is also directed to the 3-4 shift valve where it is blocked in preparation for a shift to 4th gear.

5b 3-2 Downshift Valve:

3-4 clutch fluid pressure moves the valve against spring force. This opens the valve and allows 2nd fluid to feed the 2nd clutch fluid circuit through the valve in preparation for a 3-2 downshift.

5c 3-2 Control Solenoid Valve:

The 3-2 control solenoid valve remains ON and maintains 3-2 signal fluid pressure to hold the 3-2 control valve against spring force. This action is done in preparation for control of a 3-2 downshift and does not affect transmission operation in third gear.

OVERDRIVE RANGE – THIRD GEAR

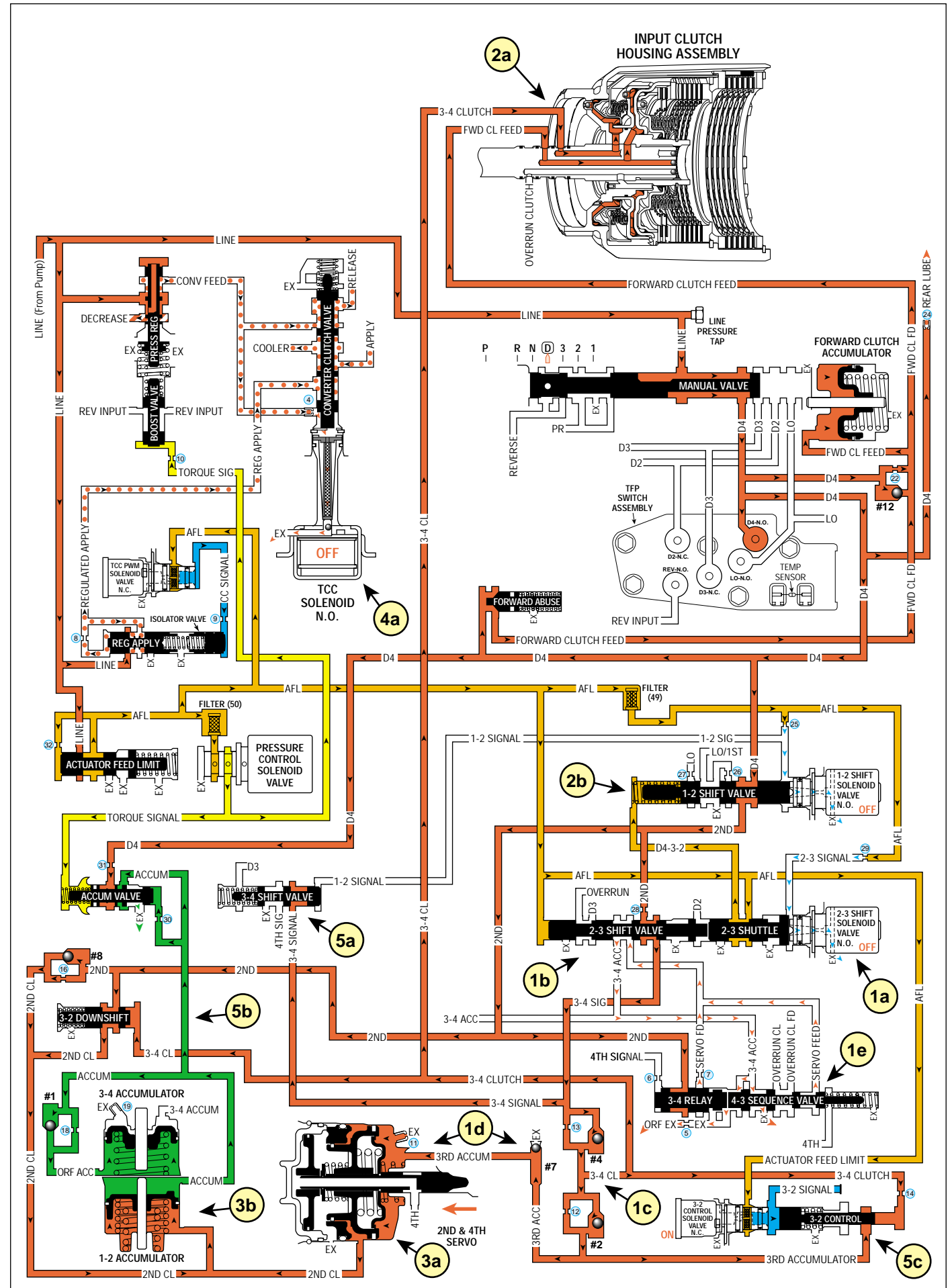

OVERDRIVE RANGE – FOURTH GEAR

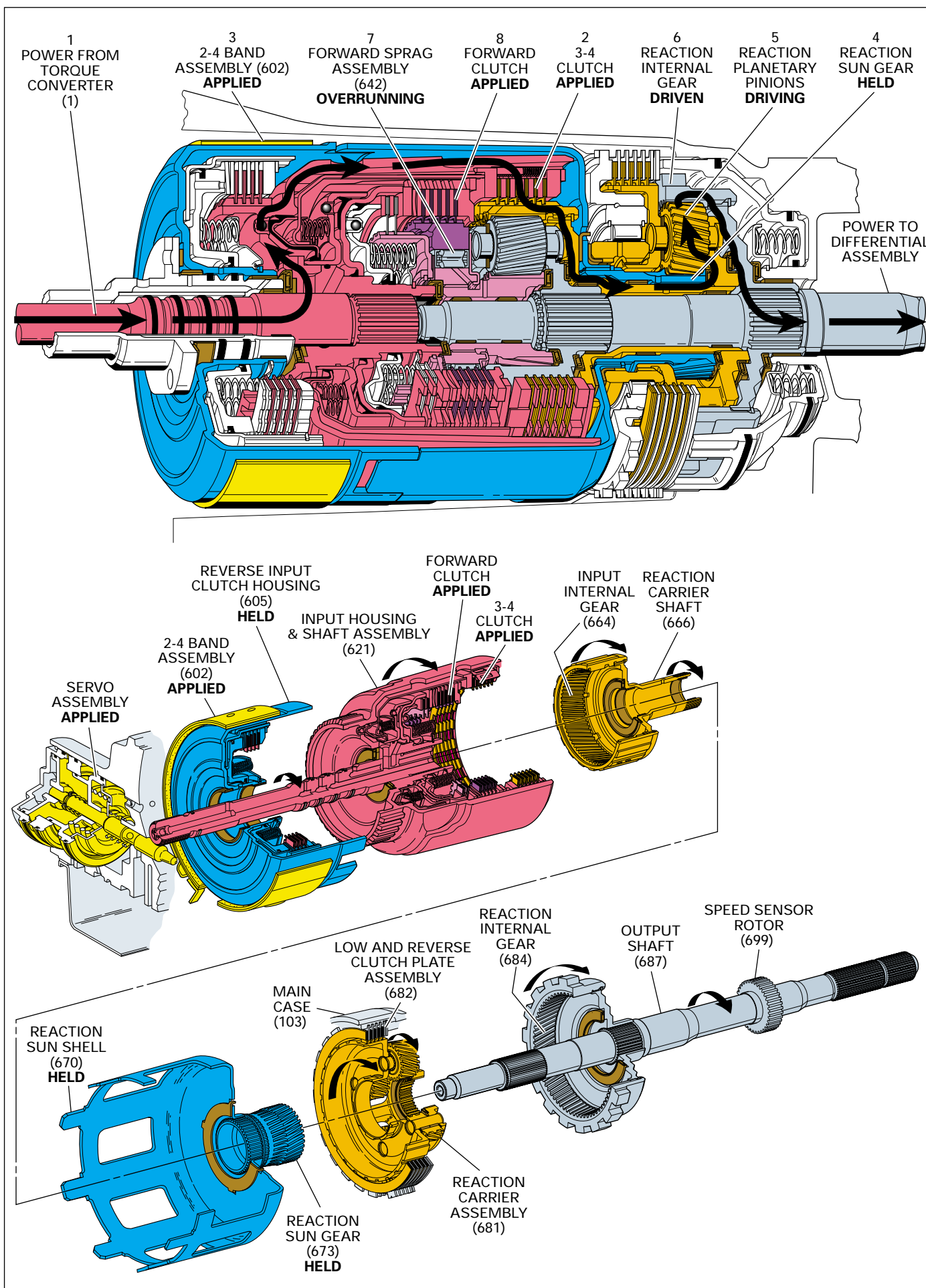

OVERDRIVE RANGE – FOURTH GEAR

1-2 SHIFT SOLENOID VALVE	2-3 SHIFT SOLENOID VALVE	2-4 BAND	REVERSE INPUT CLUTCH	OVERRUN CLUTCH	FORWARD CLUTCH	FORWARD SPRAG CL. ASSEMBLY	3-4 CLUTCH	LO-ROLLER CLUTCH	LO/REV CLUTCH
ON	OFF	APPLIED			APPLIED		APPLIED		

To maximize engine performance and fuel economy, a Fourth gear (Overdrive) is used to achieve an approximate ratio of 0.73:1 through the transmission gear sets to the vehicle drive shaft. This allows the vehicle to maintain a given road speed with less engine output speed.

- The converter clutch is applied and converter turbine speed equals engine speed (see torque converter, page 12).

1 Power from Torque Converter

The turbine shaft, connected to the input housing (621), is driven by the converter turbine.

2 3-4 Clutch Applied

The 3-4 clutch plates (654) remain applied in Fourth gear to transfer engine torque from the input housing (621) to the input internal gear (664) and reaction carrier shaft (666).

3 2-4 Band Applied

The 2-4 band (602) is applied and holds the reverse input clutch housing (605) stationary to the transmission case.

4 Reaction Sun Gear Held

The reaction sun shell (670) is splined to the reverse input clutch housing and the reaction sun gear (673) is splined to the sun shell. Both the sun shell and reaction sun gear are held stationary as a result of the 2-4 band being applied.

5 Reaction Planetary Pinions Driving

The reaction carrier shaft drives the reaction carrier assembly (681) clockwise. The reaction carrier pinion gears rotate clockwise on their pins as they walk clockwise around the stationary reaction sun gear.

6 Reaction Internal Gear Driven

The reaction carrier pinion gears drive the reaction internal gear (684) and output shaft (687) in an overdrive gear ratio of approximately 0.73:1.

7 Forward Sprag Assembly Overrunning

The output shaft drives the input carrier assembly (662), input pinion gears and forward sprag clutch inner race and input sun gear assembly (640) faster than the forward clutch is driving the forward clutch outer race (644). This allows the forward sprag clutch inner race and input sun gear assembly to overrun the forward sprag clutch (642).

8 Forward Clutch Applied

As a result, of the forward sprag clutch overrunning, the forward clutch is ineffective in Fourth gear.

- Power flow from the forward clutch housing to the output shaft (671) is the same as Overdrive Range – Third Gear. Refer to page 58A for a description of this power flow.

- With power flow between the forward clutch housing and the output shaft a 1:1 direct drive ratio, the overall transmission gear ratio is 0.75:1.

Coast Conditions/Engine Compression Braking

- In Fourth gear, neither the forward sprag clutch nor the low and reverse roller clutch are used to transfer engine torque during acceleration. Therefore, there are no elements to overrun and allow the vehicle to coast freely when the throttle is released. This causes engine compression braking to slow the vehicle. However, because of the Overdrive gear ratio, engine compression braking is not as noticeable by the driver in Fourth gear as in the manual gear ranges.

OVERDRIVE RANGE – FOURTH GEAR

(Torque Converter Clutch Applied)

1-2 SHIFT SOLENOID VALVE	2-3 SHIFT SOLENOID VALVE	2-4 BAND	REVERSE INPUT CLUTCH	OVERRUN CLUTCH	FORWARD CLUTCH	FORWARD SPRAG CL. ASSEMBLY	3-4 CLUTCH	LO-ROLLER CLUTCH	LO/REV CLUTCH
ON	OFF	APPLIED			APPLIED		APPLIED		

Overdrive Range – Fourth Gear is used to maximize engine efficiency and fuel economy under most normal driving conditions. In order to shift the transmission into Fourth gear, the PCM receives input signals from the vehicle speed sensor, the TP sensor and other vehicle sensors to determine the precise moment to energize or “turn ON” the 1-2 shift solenoid (SS) valve. The 1-2 SS valve is ON when the PCM provides a path to ground for that electrical circuit. This prevents 1-2 signal fluid from exhausting at the 1-2 SS valve, thereby increasing 1-2 signal fluid pressure.

1 2-4 BAND APPLIED

1a 1-2 Shift Solenoid (SS) Valve:

The 1-2 SS valve is energized (ON) blocking 1-2 signal fluid from exhausting through the solenoid. This creates pressure in the 1-2 signal fluid circuit.

1b 3-4 Shift Valve:

1-2 signal fluid pressure moves the valve into the upshifted position routing 3-4 signal fluid into the 4th signal fluid circuit.

1c 3-4 Relay Valve and 4-3 Sequence Valve:

4th signal fluid pressure moves both valves into the upshifted position causing the following changes.

- Orificed (#7) 2nd fluid is routed through the 3-4 relay valve and into the servo feed fluid circuit.
- Servo feed fluid is routed through the 4-3 sequence valve and into the 4th fluid circuit.
- 3-4 accumulator fluid routed from the 2-3 shuttle valve is blocked by both valves.

1d 2nd & 4th Servo:

4th fluid pressure is routed through the center of the servo apply pin and acts on the apply side of the 4th apply piston. This action moves the apply pin and applies the 2-4 band in order to obtain fourth gear.

2 3-4 SHIFT ACCUMULATION

2a 3-4 Accumulator Assembly:

3-4 accumulator fluid pressure moves the 3-4 accumulator piston absorbing some of the initial increase of 4th clutch apply fluid pressure in order to cushion the 2-4 band apply.

2b Accumulator Valve:

Accumulator fluid forced from the 3-4 accumulator is orificed to the end of the accumulator valve. This regulates the exhaust of excess accumulator fluid pressure through the middle of the valve.

3 TORQUE CONVERTER CLUTCH APPLIED

3a TCC Solenoid Valve:

When operating conditions are appropriate, the PCM energizes the normally open TCC solenoid valve. This closes the solenoid, blocks converter feed fluid from exhausting, and creates enough pressure in the converter feed fluid circuit at the TCC solenoid valve to shift the converter clutch valve.

3b Converter Clutch Apply Valve:

The converter clutch valve is shifted into the apply position allowing release fluid to exhaust from the torque converter clutch and regulated apply fluid to enter the apply fluid circuit at the same time. This provides for smooth engagement of the TCC.

OVERDRIVE RANGE – FOURTH GEAR

(Torque Converter Clutch Applied)

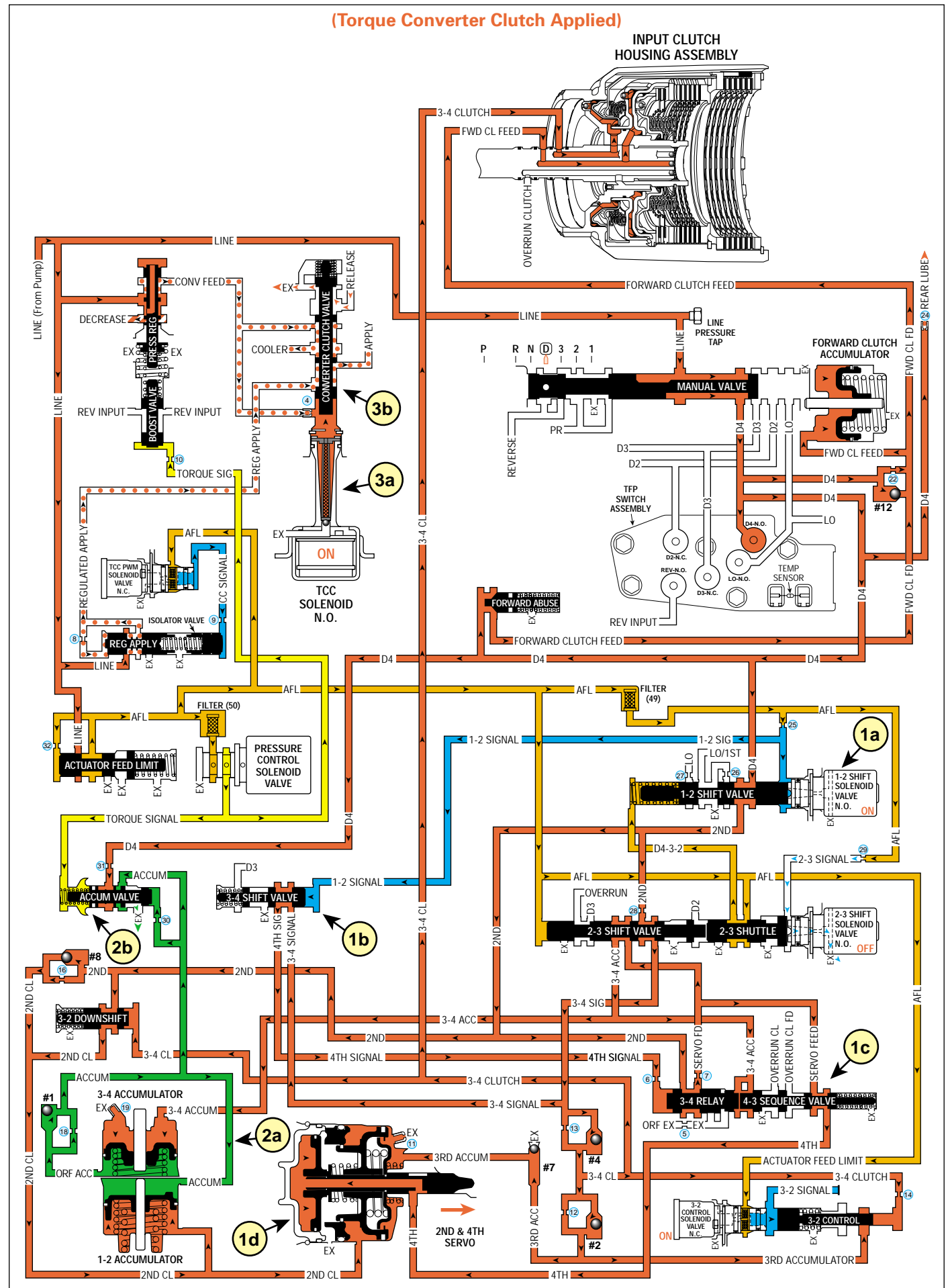
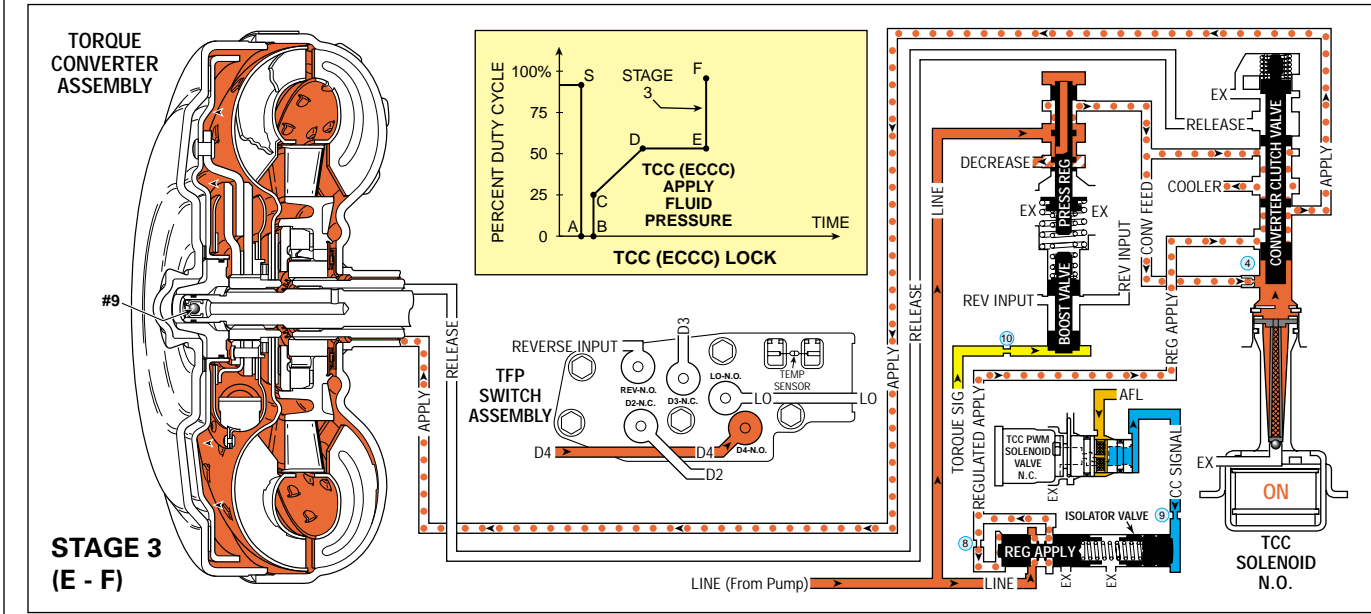
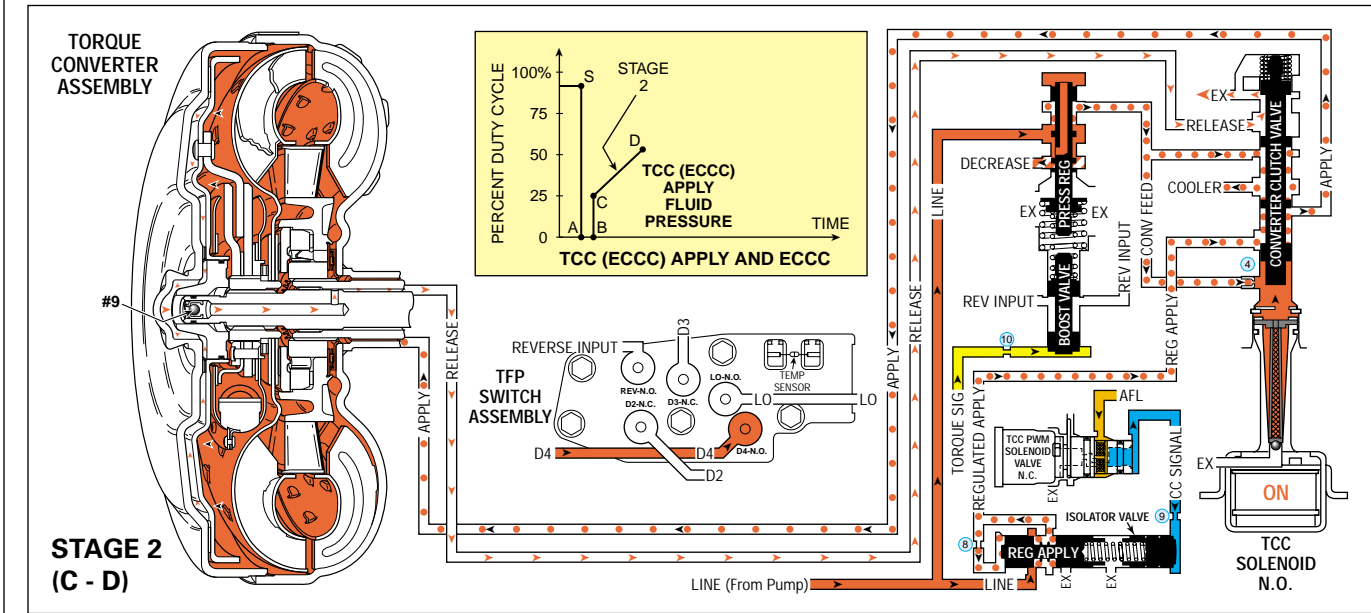
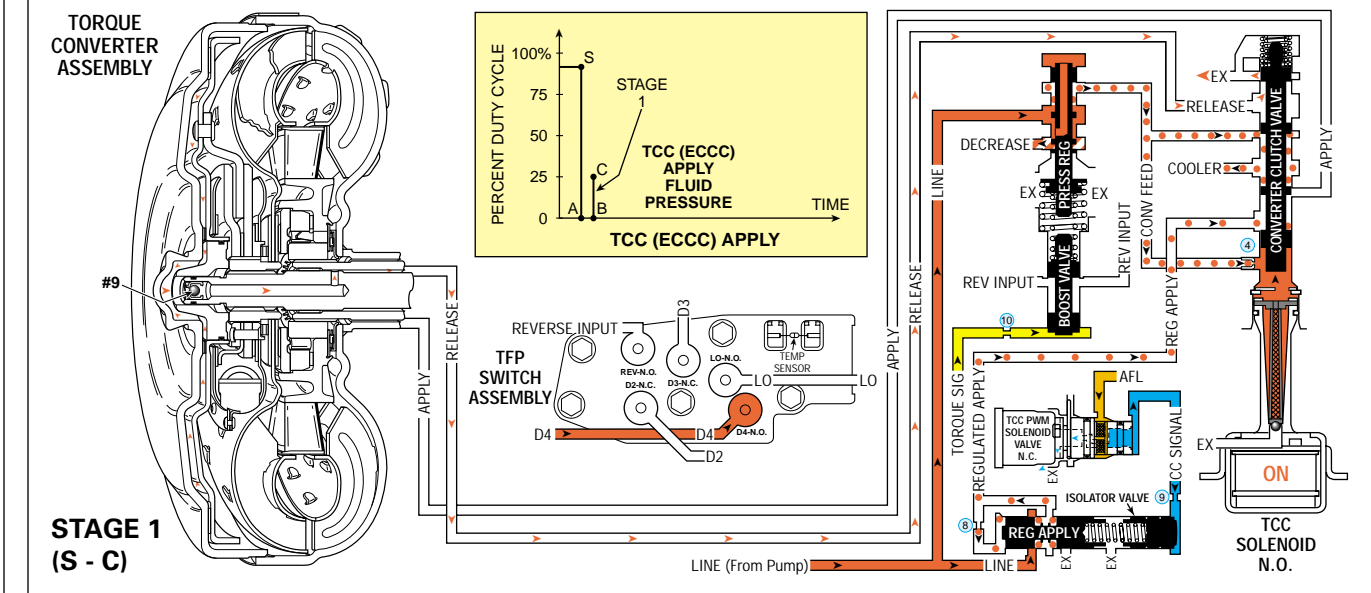

Figure 58

OVERDRIVE RANGE – FOURTH GEAR

(Torque Converter Clutch from Released to Applied)



OVERDRIVE RANGE – FOURTH GEAR

(Torque Converter Clutch from Released to Applied)

When the powertrain control module (PCM) determines that the engine and transmission are operating properly to engage the torque converter clutch (TCC), the PCM energizes the TCC solenoid valve and regulates the duty cycle of the TCC PWM solenoid valve. The following events occur in order to apply the torque converter clutch:

OFF At this time the Torque Converter Clutch is considered to be disengaged (OFF), TCC solenoid valve OFF, TCC PWM solenoid valve parked at 90% duty cycle.

PCM decision to apply TCC (see pages 39 and 43, in the Electrical Components section, for more information).

Stage 1 The PCM immediately decreases the TCC PWM solenoid valve duty cycle to 0% (from point S to point A) then pulses the TCC PWM solenoid valve to approximately 25% duty cycle from point B to point C. Actuator feed limit fluid at the TCC PWM solenoid is “pulsed” into the CC signal fluid circuit. The CC signal fluid pressure at point C regulates a line pressure branch which creates regulated apply fluid. The PCM also energizes the TCC solenoid valve, blocking converter feed fluid from exhausting through the solenoid and causing pressure to build up and shift the converter clutch valve to the apply position. With the converter clutch valve in the apply position, Release fluid can exhaust through the valve. This stage is designed to move the converter clutch valve from the released to the applied position; there is not enough pressure to apply the TCC.

Stage 2 The TCC PWM solenoid valve duty cycle is ramped up from point C to point D to approximately 50%. Regulated apply fluid pressure is now strong enough to cause the converter apply to occur. Line pressure from the pump enters the regulated apply circuit at the regulated apply valve. Regulated apply fluid is routed to the converter clutch valve into the apply fluid circuit. The pressure value in the regulated apply circuit should now be high enough to fully apply the TCC pressure plate. Slip speed should be at the correct value (near “0”).

In vehicles equipped with the Electronically Controlled Clutch Capacity (ECCC) system, the pressure plate does not fully lock to the torque converter cover. It is instead precisely controlled to maintain a small amount of slippage between the engine and the turbine, reducing driveline torsional disturbances.

Stage 3 If it is determined by the PCM that it is desirable to fully lock the TCC, regulated apply fluid pressure is increased. This is caused by the TCC PWM solenoid valve duty cycle being increased from point E to point F, to approximately 98%. This extra pressure ensures that the apply force on the TCC pressure plate is not at the slip threshold, but a little above it. TCC plate material is therefore protected from excessive heat.

Note: The TCC PWM solenoid valve operates independently from the TCC solenoid valve. The TCC solenoid valve only controls when the TCC is applied. The TCC PWM solenoid valve only controls how the TCC is applied.

Note: Under normal operating conditions the torque converter clutch is in the released position during first, second and third gears. However, when the transmission fluid temperatures exceed approximately 121°C (250°F), the PCM will apply the torque converter clutch in second and third gears to help reduce fluid temperatures.

OVERDRIVE RANGE – FOURTH GEAR

(Torque Converter Clutch from Applied to Released)

When the TCC pressure plate is applied, it is held against the torque converter cover. Since it is splined to the converter turbine hub, it provides a mechanical coupling (direct drive) of the engine to the transmission gear sets. This mechanical coupling eliminates the small amount of slippage that occurs in the fluid coupling of a torque converter, resulting in a more efficient transfer of engine torque through the transmission and to the drive wheels.

ON At this time the Torque Converter Clutch is considered to be engaged (ON).

PCM decision to release TCC (see pages 39 and 43, in the Electrical Components section, for more information).

Stage 4 During this stage, the apply fluid pressure from the regulated apply valve is decreased by the TCC PWM solenoid valve duty cycle dropping from point G to point H, to approximately 50%. Reduced CC signal fluid pressure from the TCC PWM solenoid valve allows orificed regulated apply fluid to move the regulated apply valve, decreasing the flow of line fluid feeding the regulated apply circuit. This reduces the apply force on the TCC pressure plate to the slip threshold. This gets the TCC pressure plate ready for a smooth release.

Stage 5 The TCC PWM solenoid valve duty cycle is ramped down to 0% from point H to point I through this stage. This action allows the regulated apply pressure to start at the slip threshold, and decrease to near “0” pressure over a very short time to point I. The regulated apply pressure value from the TCC regulator apply valve at this duty cycle (point I) should fully release the TCC pressure plate. Slip speed should be at the maximum value. The PCM also de-energizes the TCC solenoid allowing converter clutch valve spring force to shift the converter clutch valve to the released position. Release fluid is now directed back to the torque converter.

Stage 6 The PCM pulses the TCC PWM solenoid valve to a value of “90”. This stage is designed to prepare the TCC apply and release system for another apply of the TCC.

OFF At this time the Torque Converter Clutch is considered to be disengaged (OFF).

(Some PCM calibrations may allow stages 4 - 6 to happen very rapidly in almost a straight line down from point G to point K.)

The PCM monitors for high TCC slip for most models. Excessive slip is recognized by Diagnostic Trouble Code (DTC) P1870. The transmission must be in hot mode or experiencing a wide open throttle maneuver in order for the TCC to be commanded on in second and third gear.

If the PCM detects a continuous open, short to ground, or short to power in the TCC solenoid valve circuit, then DTC P0740 will set and the PCM will illuminate the malfunction indicator lamp (MIL), inhibit TCC operation, inhibit 4th gear and freeze shift adapts. The DTC P0740 will then be stored in PCM history.

If the PCM detects low TCC slip when the TCC is commanded OFF, then DTC P0742 will set and the PCM will illuminate the malfunction indicator lamp (MIL), increase line pressure and freeze shift adapts. The DTC P0742 will then be stored in PCM history.

OVERDRIVE RANGE – FOURTH GEAR

(Torque Converter Clutch from Applied to Released)

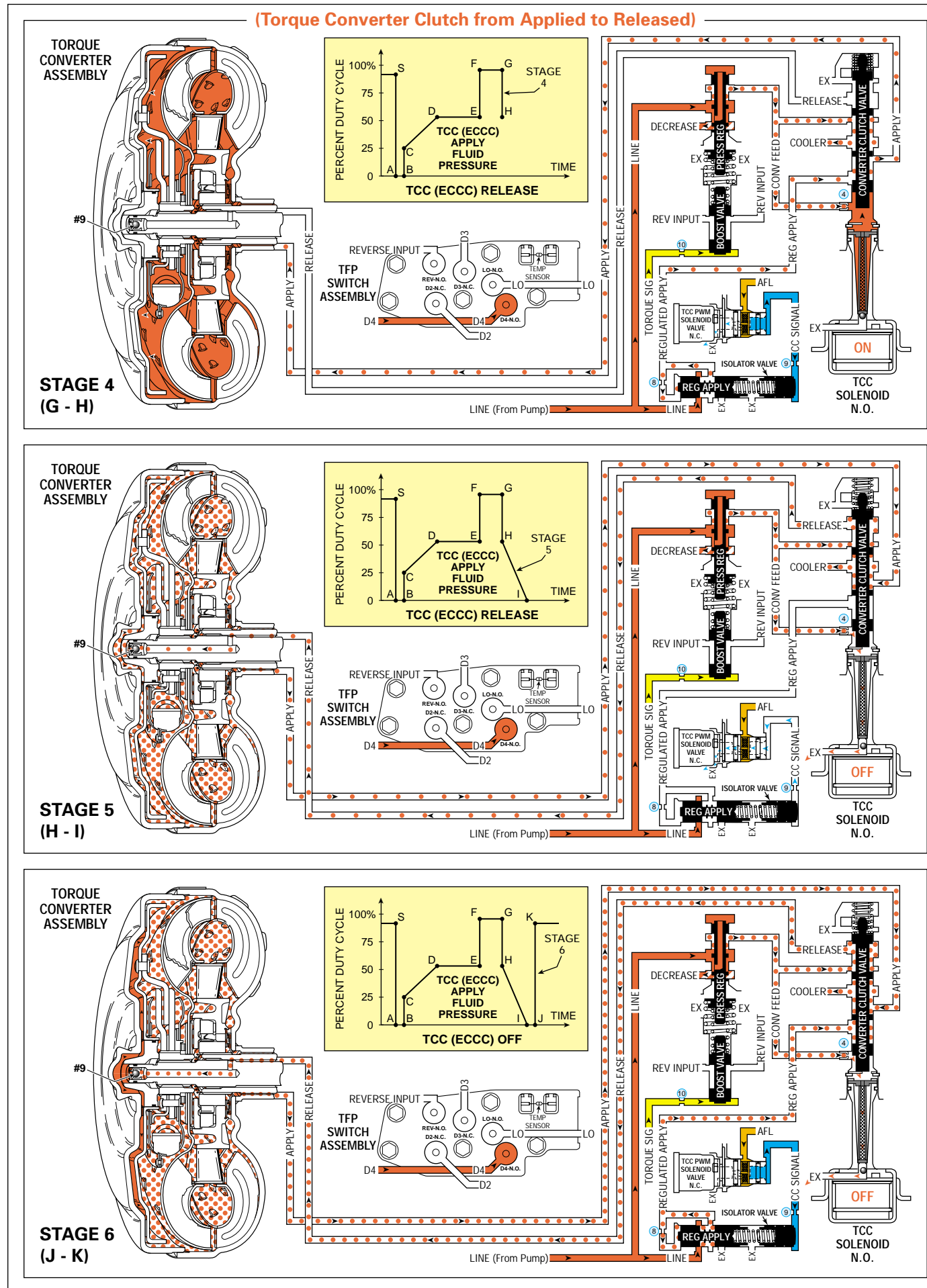
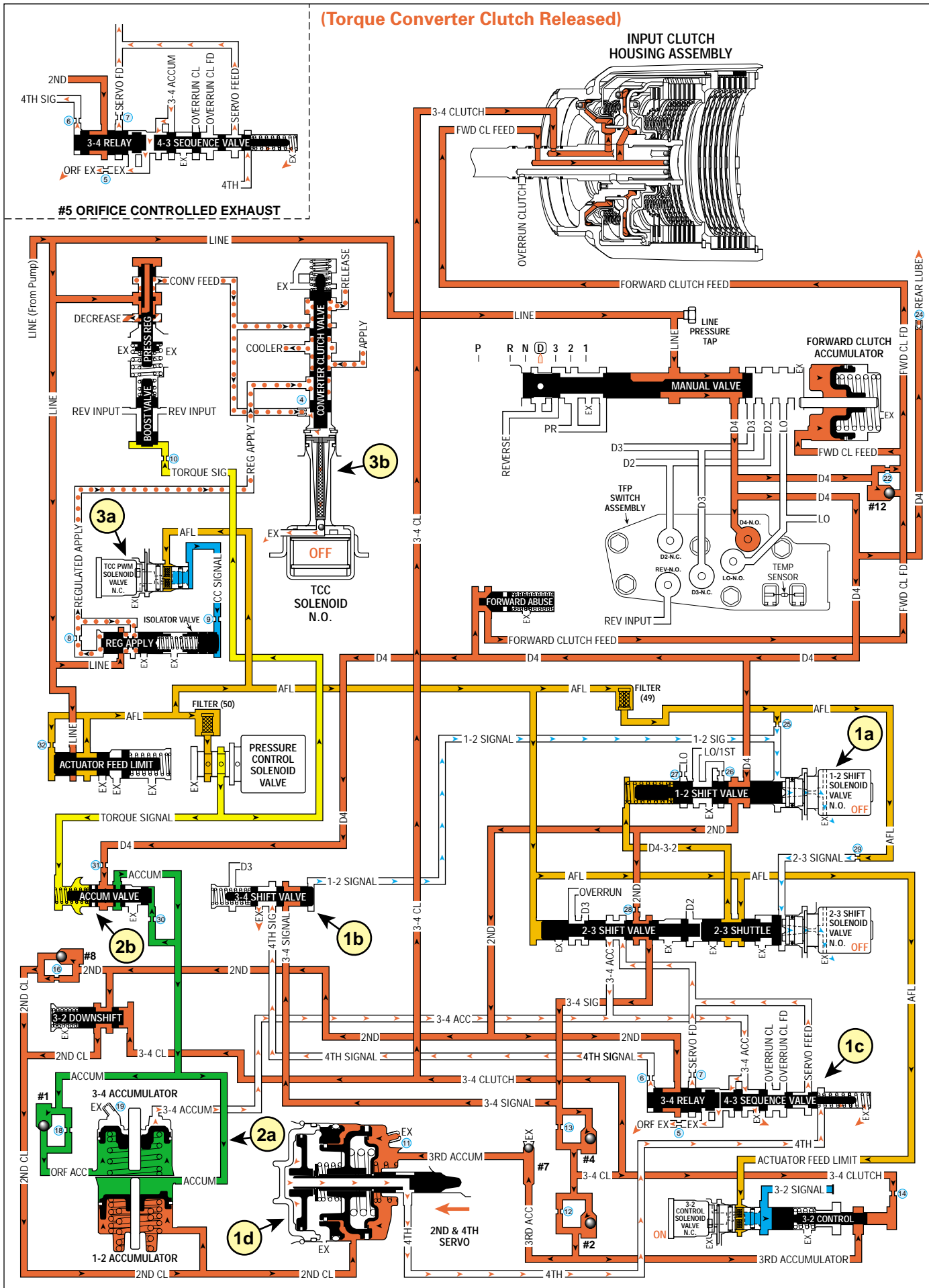

Figure 60

OVERDRIVE RANGE – 4-3 DOWNSHIFT

(Torque Converter Clutch Released)



OVERDRIVE RANGE – 4-3 DOWNSHIFT

(Torque Converter Clutch Released)

1-2 SHIFT SOLENOID VALVE	2-3 SHIFT SOLENOID VALVE	2-4 BAND	REVERSE INPUT CLUTCH	OVERRUN CLUTCH	FORWARD CLUTCH	FORWARD SPRAG CL. ASSEMBLY	3-4 CLUTCH	LO-ROLLER CLUTCH	LO/REV CLUTCH
OFF	OFF				APPLIED	HOLDING	APPLIED		

A forced 4-3 downshift in Overdrive range occurs by increasing the throttle valve angle (percentage of accelerator pedal travel or throttle position) while the vehicle is operating in Fourth gear. A 4-3 downshift can also occur when the vehicle is decelerating during coast conditions or when load on the vehicle is increased. Also, if the TCC is applied in Fourth gear it will release prior to the transmission making a 4-3 downshift. Under normal operating conditions the PCM will keep the converter clutch released in Third gear. The TCC also releases under minimum and heavy throttle conditions. Figure 61 shows the TCC PWM solenoid valve de-energized and the TCC released. Refer to pages 62A and 62B for descriptions of the torque converter clutch hydraulic and electrical circuits during release and apply.

A 4-3 downshift occurs when the PCM receives the appropriate input signals to de-energize or "turn OFF" current supply to the 1-2 shift solenoid (SS) valve (opens the ground path of the circuit). During a 4-3 downshift, the following changes occur to the hydraulic system:

1 2-4 BAND RELEASES

1a 1-2 Shift Solenoid (SS) Valve:

De-energized by the PCM, the normally open solenoid opens and 1-2 signal fluid exhausts through the solenoid.

1b 3-4 Shift Valve:

With the 1-2 signal fluid pressure exhausted, the spring force moves the valve into the downshifted position. In this position, the valve blocks the 3-4 signal fluid and the 4th signal fluid exhausts past the valve.

1c 3-4 Relay Valve and 4-3 Sequence Valve:

Actuator feed limit fluid pressure and spring force move the 3-4 shift valve to the downshifted position. This blocks 4th clutch feed at the 3-4 shift valve and opens the 4th clutch fluid circuit to an orificed exhaust.

1d 2nd & 4th Servo:

The 4th fluid exhausts from the 4th apply piston in the servo assembly. The apply pin spring moves the 4th apply piston and the apply pin in order to release the band from the reverse input drum and shift the transmission into third gear.

2 SHIFT ACCUMULATION

2a 3-4 Accumulator Assembly:

The 3-4 accumulator fluid exhausts from the 3-4 accumulator piston. The orificed accumulator fluid pressure and the spring force move the piston into a third gear position.

2b Accumulator Valve:

Biased by torque signal fluid pressure and spring force, the accumulator valve regulates the D4 fluid into the accumulator fluid circuit.

3 TORQUE CONVERTER

3a TCC PWM Solenoid Valve:

The PCM de-energizes the TCC solenoid valve, and operates the duty cycle of the TCC PWM solenoid valve to release the converter clutch for a smooth disengagement, prior to initiating the 4-3 downshift.

3b TCC Solenoid Valve:

The TCC solenoid valve is de-energized by the PCM. This causes converter feed fluid pressure to exhaust through the solenoid and allows the converter clutch valve to shift to the release position.

COMPLETE HYDRAULIC CIRCUIT
Page 88

1-2 SHIFT SOLENOID VALVE	2-3 SHIFT SOLENOID VALVE	2-4 BAND	REVERSE INPUT CLUTCH	OVERRUN CLUTCH	FORWARD CLUTCH	FORWARD SPRAG CL. ASSEMBLY	3-4 CLUTCH	LO-ROLLER CLUTCH	LO/REV CLUTCH
OFF	ON	APPLIED			APPLIED	HOLDING			

A forced 3-2 downshift occurs by increasing throttle valve angle (percentage of accelerator pedal travel or throttle position) while the vehicle is operating in Third gear. As with a 4-3 downshift, a 3-2 downshift can also occur when the vehicle is decelerating during coast conditions or when load on the vehicle increases.

A 3-2 downshift occurs when the PCM receives the appropriate input signals to de-energize or “turn OFF” current supply to the 2-3 shift solenoid (SS) valve (open the ground path of the circuit). During a 3-2 downshift, the following changes occur to the hydraulic system:

1 3-4 CLUTCH RELEASED

1a 2-3 Shift Solenoid (SS) Valve:

The 2-3 SS valve is energized (ON) blocking 2-3 signal fluid from exhausting through the solenoid. This creates pressure in the 2-3 signal fluid circuit.

1b 2-3 Shift Valve and 2-3 Shuttle Valve:

The 2-3 signal fluid pressure moves both valves to the downshifted position. This causes the following changes.

- The AFL fluid is blocked from the D432 fluid circuit causing the D432 fluid to exhaust past the 2-3 shuttle valve.
- The 2nd fluid is blocked from feeding the 3-4 signal fluid circuit and is routed into the servo feed fluid circuit.
- The 3-4 signal fluid is exhausted past the valve. The 3-4 clutch fluid and the 3rd accumulator fluid also exhaust.

1c 2nd & 4th Servo:

The 3rd accumulator fluid exhausts from the servo assembly. The 2nd clutch fluid pressure moves the 2nd apply piston against the servo return spring force in order to move the apply pin and apply the 2-4 band.

1d 3-4 Shift Valve:

The 3-4 signal fluid pressure exhausts from the 3-4 shift valve.

1e 3-2 Control Solenoid Valve and 3-2 Control Valve:

These components are used to increase the exhaust rate of 3rd accumulator fluid, as needed, depending on the vehicle speed. The 3-2 control solenoid valve is a normally closed On/Off solenoid controlled by the PCM. The PCM controls the solenoid state during a 3-2 downshift according to vehicle speed.

1f 3-2 Downshift Valve:

The 3-4 clutch fluid exhausts from the valve and the spring force moves the valve into the second gear position.

1g 3rd Accumulator Ball Check Valve (#2):

The exhausting 3rd accumulator fluid seats the #2 ball check valve and is forced through orifice #12. This fluid exhausts through the 3-4 clutch and the 3-4 signal fluid circuits and past the 2-3 shift valve. Orifice #12 slows the exhaust of the 3rd accumulator fluid and delays the 2-4 band apply rate.

2 2-4 BAND APPLIED

2a 3rd Accumulator:

3rd accumulator fluid pressure and 3rd accumulator spring force move the 3rd accumulator piston to a Second gear position.

2b Accumulator Valve:

The 3rd accumulator fluid circuit is supplied by accumulator fluid through the orifice opposite the #5 ball check valve. The accumulator valve regulates drive fluid into the accumulator circuit.

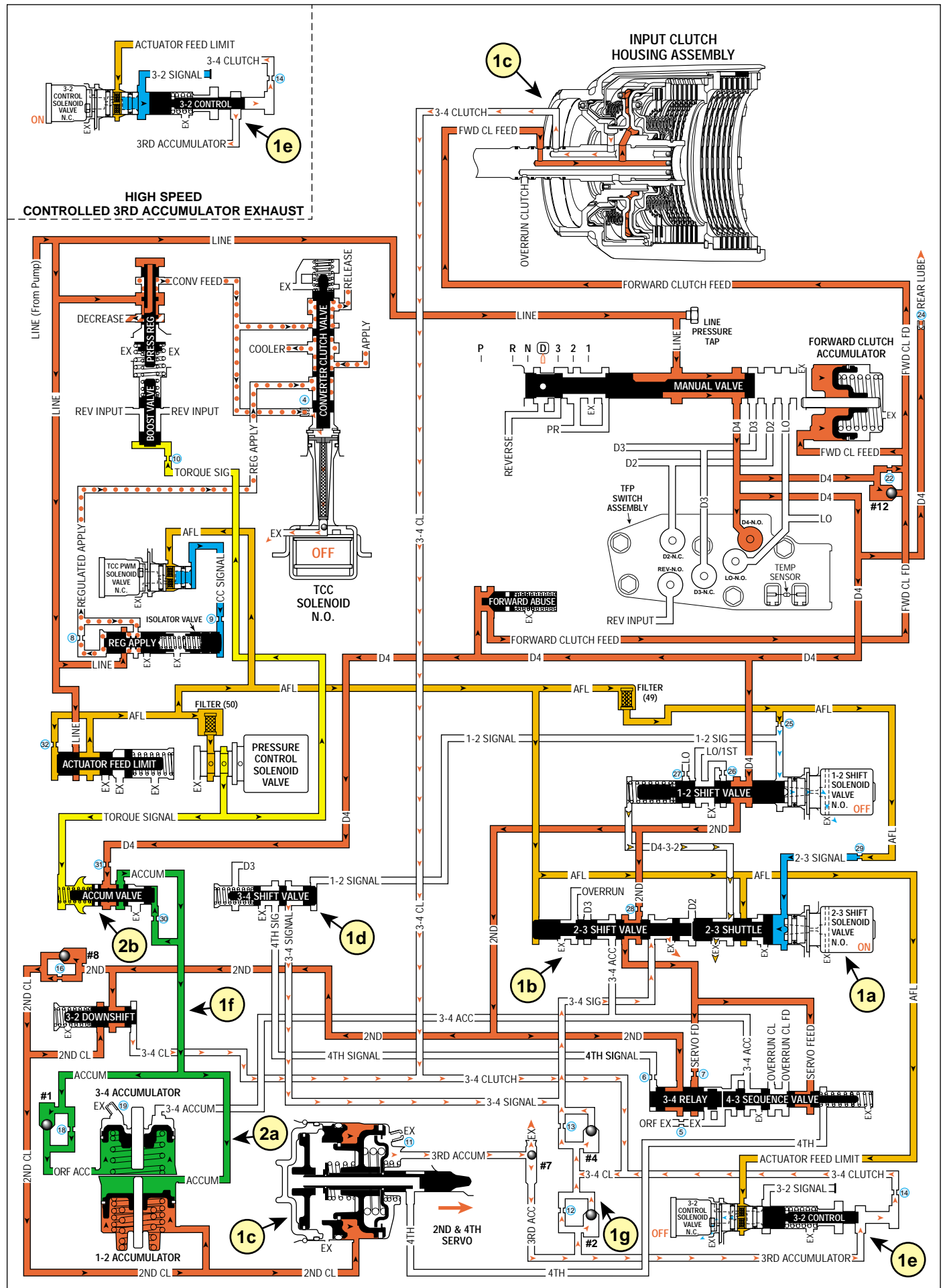

MANUAL THIRD – THIRD GEAR

(from Overdrive Range – Fourth Gear)

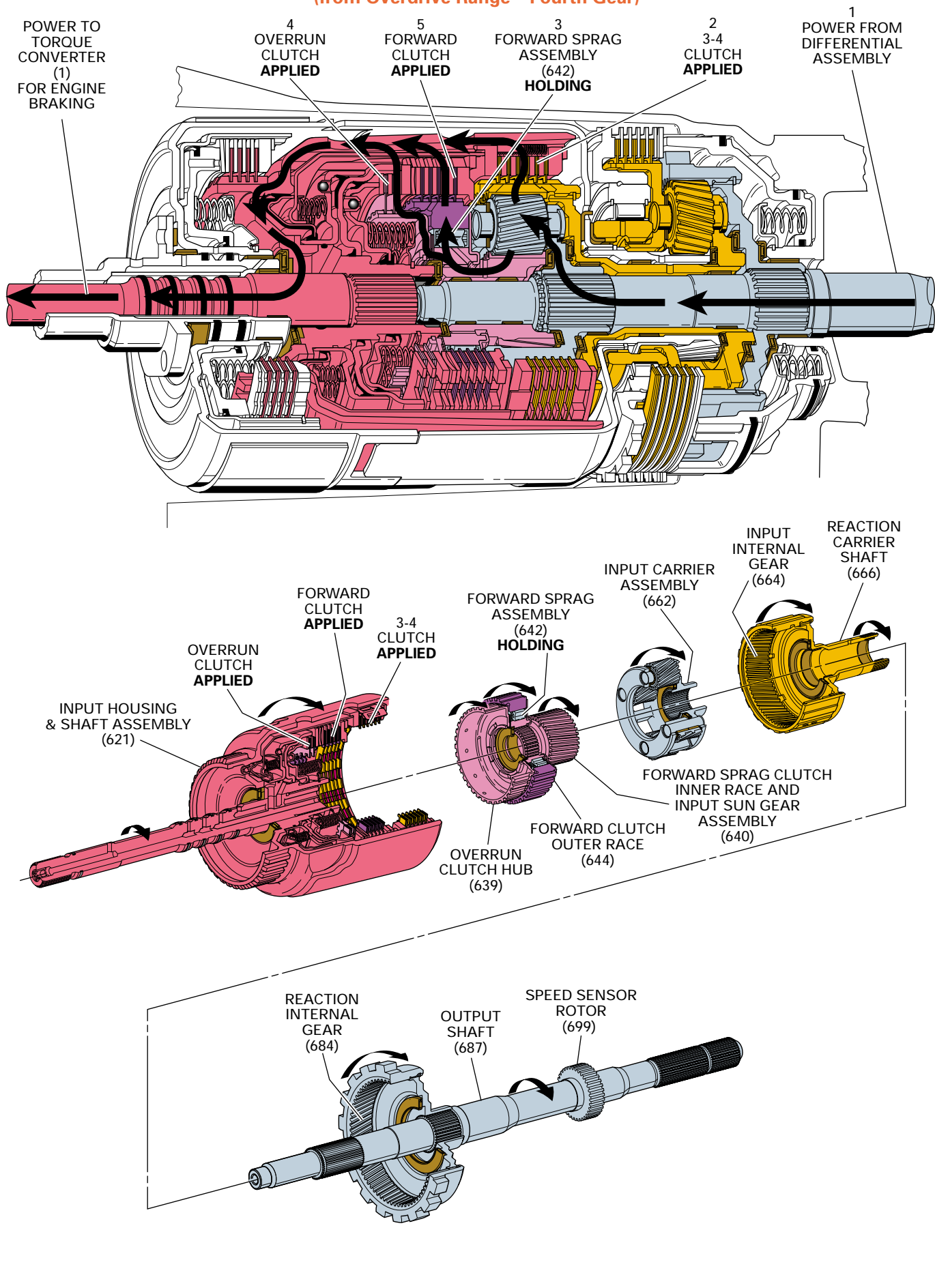

MANUAL THIRD – THIRD GEAR

(from Overdrive Range – Fourth Gear)

1-2 SHIFT SOLENOID VALVE	2-3 SHIFT SOLENOID VALVE	2-4 BAND	REVERSE INPUT CLUTCH	OVERRUN CLUTCH	FORWARD CLUTCH	FORWARD SPRAG CL. ASSEMBLY	3-4 CLUTCH	LO-ROLLER CLUTCH	LO/REV CLUTCH
OFF	OFF			APPLIED	APPLIED	HOLDING	APPLIED		

Drive Range – Manual Third (D) is available to the driver when vehicle operating conditions make it desirable to use only three gear ratios. These conditions include city driving [where speeds are generally below 72 km/h (45 mph)], towing a trailer, or driving in hilly terrain. Manual Third also provides for engine compression braking when descending slight grades and can be used to retain Third gear when ascending slight grades for additional engine performance. Manual Third is also referred to as Drive Range because it has a 1:1 direct drive gear ratio available through the transmission gear sets.

In Manual Third, the transmission can upshift and downshift between First, Second and Third gears in the same manner as Overdrive Range. However, the transmission is prevented from shifting into Fourth gear while operating in this gear selector position. If the transmission is in Overdrive Range – Fourth Gear when Manual Third is selected, the transmission will immediately shift into Third gear.

Note: Transfer of engine torque during acceleration is identical to Overdrive Range – Third Gear (refer to page 58A). The power flow in Figure 63 and the following text describes conditions during deceleration (zero or minimum throttle conditions) and how engine compression braking is achieved.

Vehicle speed provides the torque input to the transmission through the drive shaft and transmission output shaft (687). This is shown by the direction of the power flow arrows in the drawing at the top of Figure 63. Notice that this flow is identical to Overdrive Range – Third Gear except that the arrows are in the opposite direction.

1 Power From the Differential Assembly

Power flow is transferred back through the transmission from the output shaft to the input clutch housing (621). Each of the component's function and rotation direction is the same as during acceleration (compare Figures 55 and 63).

2 3-4 Clutch Applied

The 3-4 clutch is applied and power from the output shaft travels to the input housing.

3 Forward Sprag Assembly Holding

Power from the output shaft also travels through the forward sprag clutch inner race and input sun gear assembly (640) to the forward sprag assembly (642). The inner race of the forward sprag assembly is attached to the overrun clutch hub. The inner race is held when the overrun clutch is applied, and the outer race is held with the forward clutch applied.

4 Overrun Clutch Applied

With the overrun clutch applied, power from vehicle speed is prevented from overrunning the forward sprag clutch when the throttle is released. This power is transferred back through the overrun clutch and to the engine, thereby allowing engine compression to slow the vehicle when the throttle is released.

5 Forward Clutch Applied

The forward clutch is applied but is only effective in a coast condition because the overrun clutch is applied.

In Manual Third range – First and Second gears, the forward sprag assembly overruns and engine compression braking is not available. First and Second gears operate the same as in Overdrive Range, except for the overrun clutch being applied, and the vehicle is allowed to coast freely when the throttle is released. To obtain increased engine compression braking at slower speeds, the gear selector must be moved to the Manual Second position.

MANUAL THIRD – THIRD GEAR

(from Overdrive Range – Fourth Gear)

1-2 SHIFT SOLENOID VALVE	2-3 SHIFT SOLENOID VALVE	2-4 BAND	REVERSE INPUT CLUTCH	OVERRUN CLUTCH	FORWARD CLUTCH	FORWARD SPRAG CL. ASSEMBLY	3-4 CLUTCH	LO-ROLLER CLUTCH	LO/REV CLUTCH
OFF	OFF			APPLIED	APPLIED	HOLDING	APPLIED		

Drive Range – Manual Third may be selected at any time while the vehicle is being operated in a forward gear range. However, the transmission's hydraulic system prevents the transmission from shifting into Fourth gear regardless of PCM control. When the gear selector lever is moved to Drive Range (D) from Overdrive Range (D), the manual valve also moves. Changes to the hydraulic and electrical systems are as follows:

1 FOURTH GEAR PREVENTED

1a Manual Valve:

The gear selector lever, selector shaft and manual valve are moved to Manual Third (D) position.

1b Transmission Fluid Pressure (TFP) Manual Valve Position Switch:

D3 fluid is routed to the TFP manual valve position switch and opens the normally closed D3 fluid pressure switch.

1c 2-3 Shift Valve Train:

With the 2-3 SS valve de-energized and open, AFL fluid acting on the 2-3 shift valve holds both valves in the upshifted position. D3 fluid feeds the overrun fluid circuit through the 2-3 shift valve.

1d 3-4 Shift Valve:

D3 fluid pressure assists spring force to keep the valve in the downshifted position. This blocks 3-4 signal fluid and allows the 4th signal fluid circuit to exhaust. Therefore fourth gear is hydraulically prevented.

2 OVERRUN CLUTCH APPLIES

2a 1-2 Shift Solenoid (SS) Valve:

When manual third is selected, the PCM de-energizes the 1-2 SS valve to immediately downshift the transmission into third gear.

2b 3-4 Relay Valve and 4-3 Sequence Valve:

4th signal fluid pressure is exhausted. Overrun clutch feed fluid pressure assists spring force and closes both valves allowing it to fill the overrun clutch fluid circuit.

2c 2nd & 4th Servo:

The 4th fluid exhausts from the 4th apply piston in the servo assembly. The apply pin spring moves the 4th apply piston and the apply pin in order to release the band from the reverse input drum and shift the transmission into third gear.

3 SHIFT ACCUMULATION – Same as 4-3 Downshift

4 TORQUE CONVERTER

4a TCC PWM Solenoid Valve:

The PCM de-energizes the TCC solenoid valve, and operates the duty cycle of the TCC PWM solenoid valve to release the converter clutch for a smooth disengagement, prior to initiating the 4-3 downshift.

4b TCC Solenoid Valve:

The TCC solenoid valve is de-energized by the PCM. This causes converter feed fluid pressure to exhaust through the solenoid and allows the converter clutch valve to shift to the release position.

MANUAL THIRD – THIRD GEAR

(from Overdrive Range – Fourth Gear)

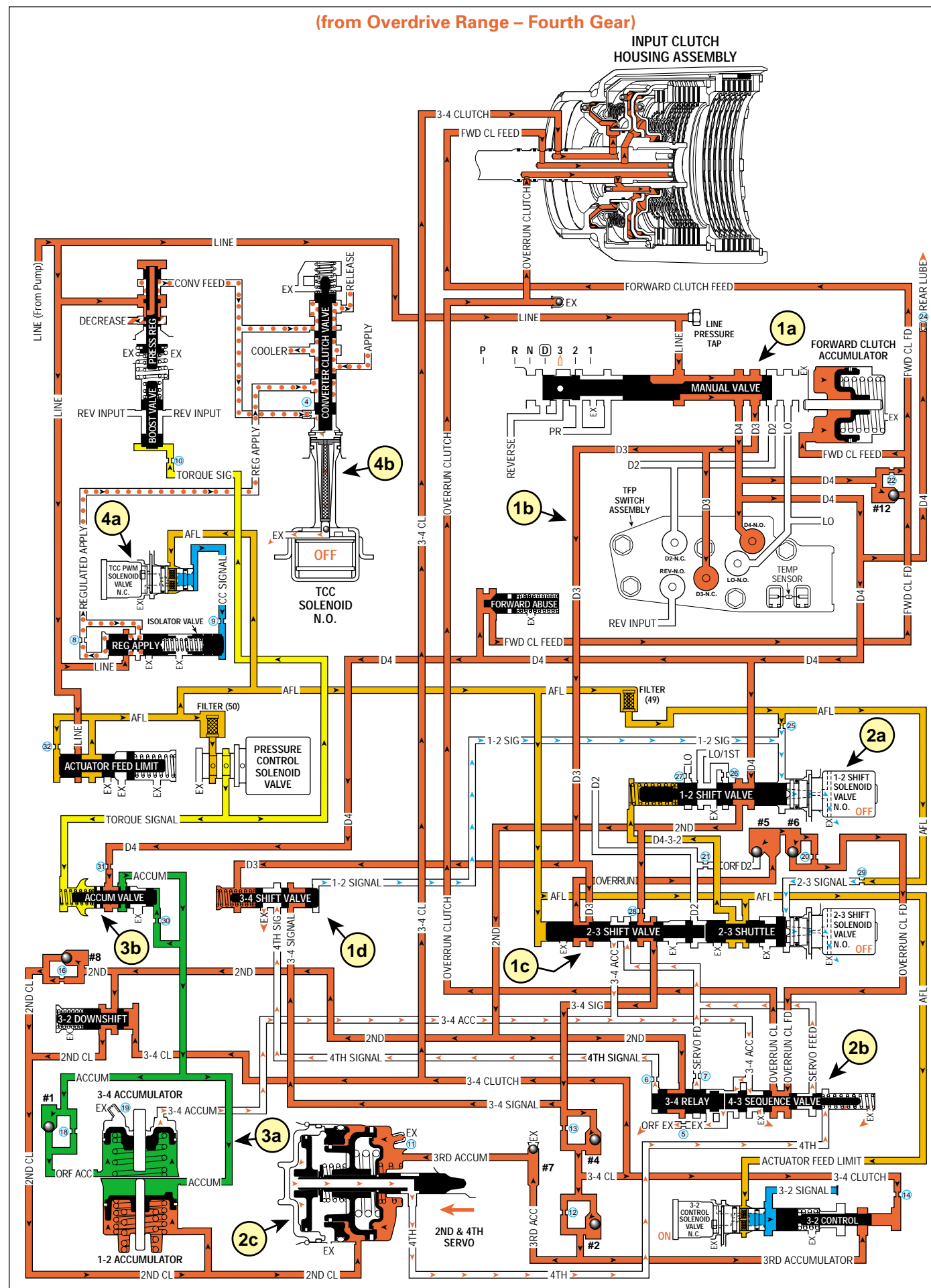

COMPLETE HYDRAULIC CIRCUIT
Page 92

Figure 64

MANUAL SECOND – SECOND GEAR

MANUAL SECOND – SECOND GEAR

(from Manual Third – Third Gear)

1-2 SHIFT SOLENOID VALVE	2-3 SHIFT SOLENOID VALVE	2-4 BAND	REVERSE INPUT CLUTCH	OVERRUN CLUTCH	FORWARD CLUTCH	FORWARD SPRAG CL. ASSEMBLY	3-4 CLUTCH	LO-ROLLER CLUTCH	LO/REV CLUTCH
OFF	ON	APPLIED		APPLIED	APPLIED	HOLDING			

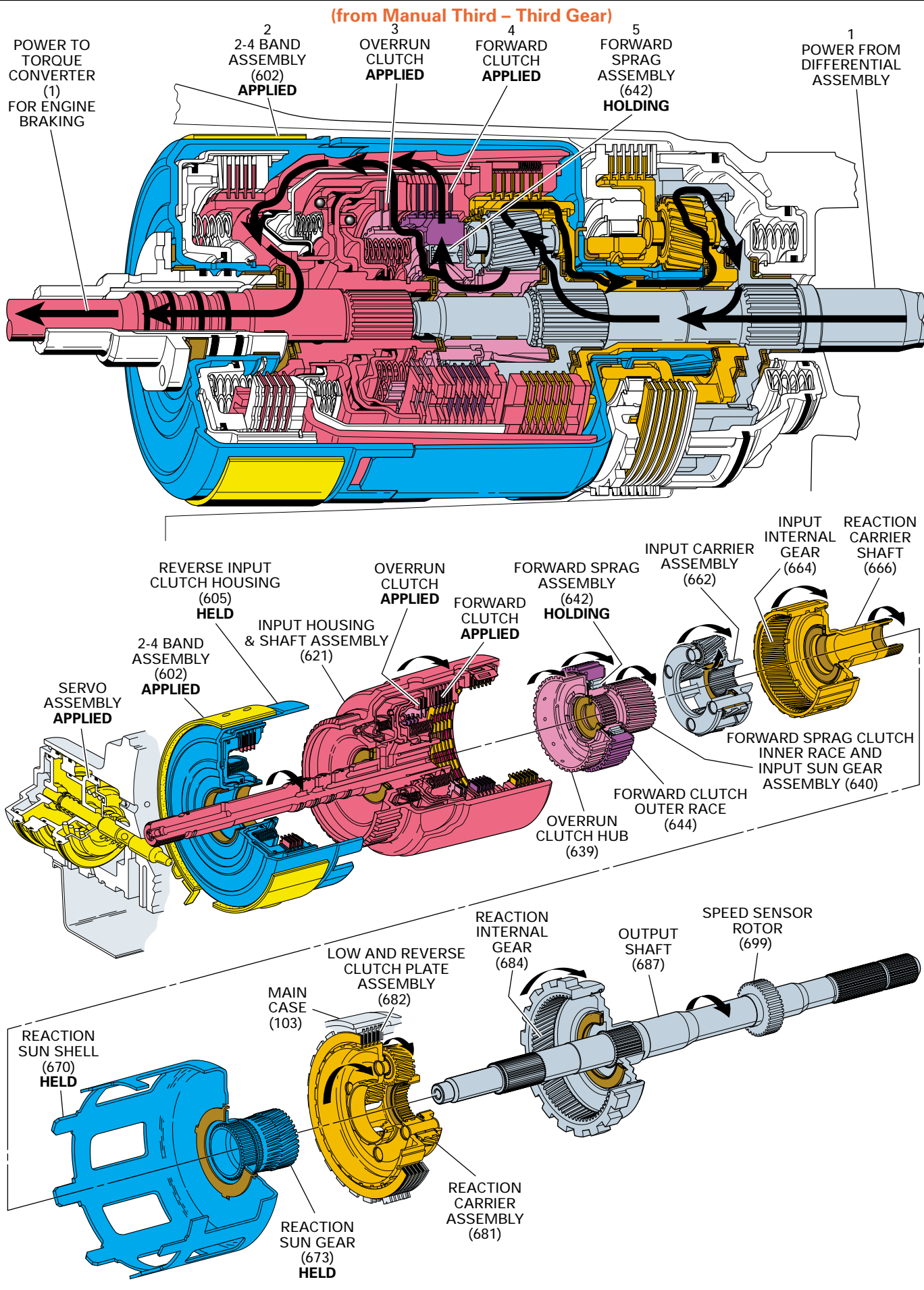

Manual Second (2) gear range is available to the driver when vehicle operating conditions make it desirable to use only two gear ratios. These conditions include descending a steep grade when engine compression braking is needed, or to retain second gear when ascending a steep grade for additional engine performance.

In Manual Second, the transmission can upshift and downshift between First and Second gear but is prevented from shifting into Third or Fourth gear. If the transmission is in Third or Fourth gear when Manual Second is selected, the transmission will shift immediately into Second gear.

Note: First gear in the Manual Second gear selector position is only available on some models at low speeds and under heavy throttle.

Note: Transfer of engine torque during acceleration is identical to Overdrive Range – Second Gear (refer to page 56A) to obtain an approximate gear ratio reduction of 1.63:1 through the transmission gear sets. The power flow in Figure 65 and the following text describes conditions during deceleration (zero or minimum throttle) and how engine compression braking is achieved.

Vehicle speed provides the torque input to the transmission through the drive shaft and transmission output shaft (687). This is shown by the direction of the power flow arrows in the drawing at the top of Figure 65. Notice that this flow is identical to Overdrive Range – Second Gear except that the arrows are in the opposite direction.

1 Power From the Differential Assembly

Vehicle speed attempts to drive the input carrier (662) faster than engine speed is driving the input housing and shaft assembly (621).

2 2-4 Band Assembly Applied

The 2-4 band is applied and holds the reverse input clutch housing which is tanged to the reaction sun shell and is held by the 2-4 band. Power from the differential travels through the reaction carrier and back to the input carrier to create second gear reduction for engine compression braking.

3 Overrun Clutch Applied

With the overrun clutch applied, power from vehicle speed is prevented from overrunning the forward sprag clutch when the throttle is released. This power is transferred back through the overrun clutch and to the engine, thereby allowing engine compression to slow the vehicle when the throttle is released.

4 Forward Clutch Applied

The forward clutch is applied but only effective in a coast condition because the overrun clutch is applied.

5 Forward Sprag Assembly Holding

Power from the output shaft also travels through the forward sprag clutch inner race and input sun gear assembly to the forward sprag assembly. The inner race of the forward sprag assembly is attached to the overrun clutch hub. The inner race is held when the overrun clutch is applied, and the outer race is held with the forward clutch applied.

The overrun clutch remains applied in Manual Second – First Gear to provide engine compression braking.

MANUAL SECOND – SECOND GEAR

(from Manual Third – Third Gear)

1-2 SHIFT SOLENOID VALVE	2-3 SHIFT SOLENOID VALVE	2-4 BAND	REVERSE INPUT CLUTCH	OVERRUN CLUTCH	FORWARD CLUTCH	FORWARD SPRAG CL. ASSEMBLY	3-4 CLUTCH	LO-ROLLER CLUTCH	LO/REV CLUTCH
OFF	ON	APPLIED		APPLIED	APPLIED	HOLDING			

Manual Second may be selected at any time while the vehicle is being operated in a forward gear range. However, the transmission's hydraulic system prevents the transmission from upshifting above Second gear regardless of PCM control. When the gear selector lever is moved to Manual Second (2) from Manual Third – Third Gear, the manual valve also moves. Changes to the hydraulic and electrical systems are as follows:

1 MANUAL VALVE

The selector lever moves the manual shaft and the manual valve into the manual second (2) position. This allows the line pressure to enter the D2 fluid circuit.

2 TRANSMISSION FLUID PRESSURE (TFP) SWITCH

The D2 fluid is routed to the TFP manual valve position switch where it opens the normally closed D2 fluid pressure switch.

3 BALL CHECK VALVE #5

D2 fluid feeds the orificed D2 fluid circuit seating the #5 ball check valve and exhausting overrun fluid through the 2-3 shift valve.

4 THIRD AND FOURTH GEARS PREVENTED

4a 2-3 Shift Solenoid (SS) Valve:

The PCM energizes the 2-3 SS valve and the AFL fluid pressure holds the 2-3 shift valve in the downshifted position. This electronically prevents operation of the third and fourth gears.

4b 2-3 Shift Valve Train:

The D2 fluid is routed between the 2-3 shuttle valve and the 2-3 shift valve causing the following:

- The 2nd fluid is blocked from entering the 3-4 signal fluid circuit and the 3-4 signal fluid circuit is open to an exhaust port at the valve.
- The 3-4 clutch cannot apply with the 3-4 signal fluid exhausted. Therefore, third and fourth gears are hydraulically prevented.
- The 2nd fluid feeds the servo feed fluid circuit, but has no function in manual second.
- The AFL fluid is blocked by the 2-3 shift valve and the D432 fluid circuit is exhausted through the valve.
- The overrun fluid is exhausted through the 2-3 shift valve.

4c 2nd & 4th Servo:

The 3rd accumulator fluid exhausts from the servo assembly. The 2nd clutch fluid pressure moves the 2nd apply piston against the servo return spring force in order to move the apply pin and apply the 2-4 band.

4d 3-2 Control Solenoid Valve and 3-2 Control Valve:

These components are used to increase the exhaust rate of 3rd accumulator fluid, as needed, depending on the vehicle speed. The 3-2 control solenoid valve is a normally closed On/Off solenoid controlled by the PCM. The PCM controls the solenoid state during a 3-2 downshift according to vehicle speed.

4e 3-2 Downshift Valve:

The 3-4 clutch fluid exhausts from the valve and the spring force moves the valve into the second gear position.

4f 3-4 Shift Valve:

The 3-4 signal fluid pressure exhausts from the 3-4 shift valve but has no effect on the valve.

MANUAL SECOND – SECOND GEAR

(from Manual Third – Third Gear)

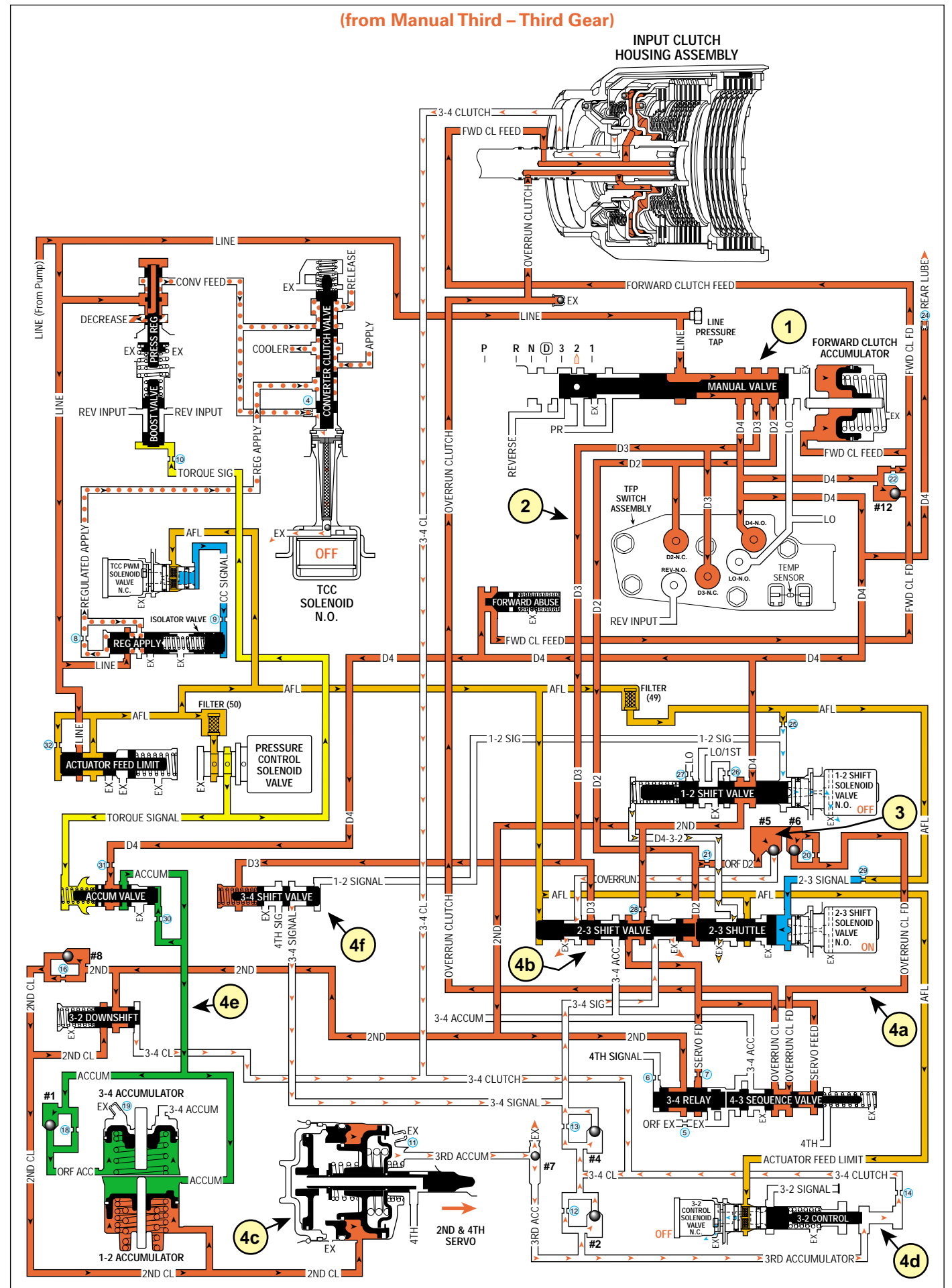

COMPLETE HYDRAULIC CIRCUIT
Page 94

Figure 66

MANUAL FIRST – FIRST GEAR

(from Manual Second – Second Gear)

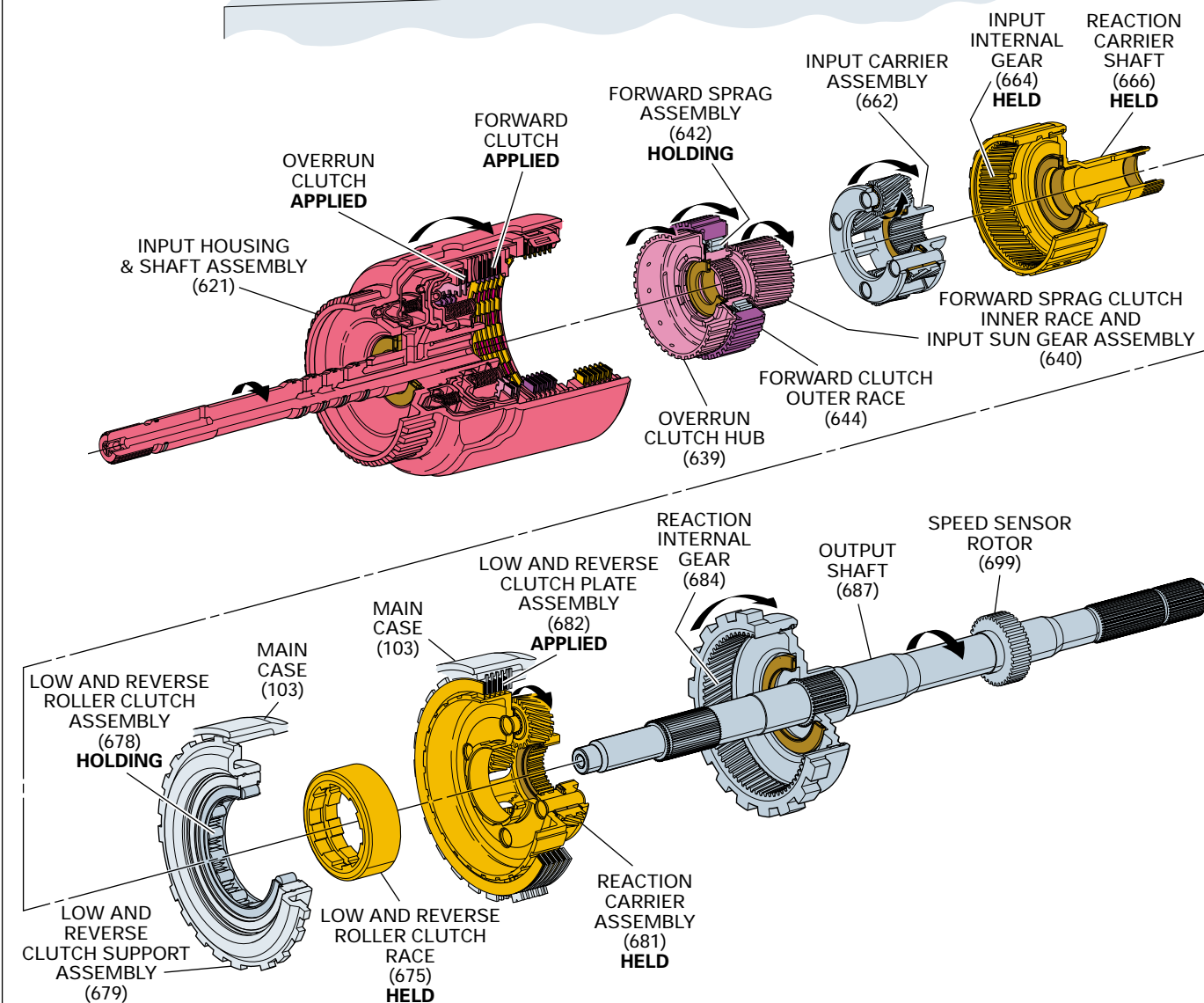
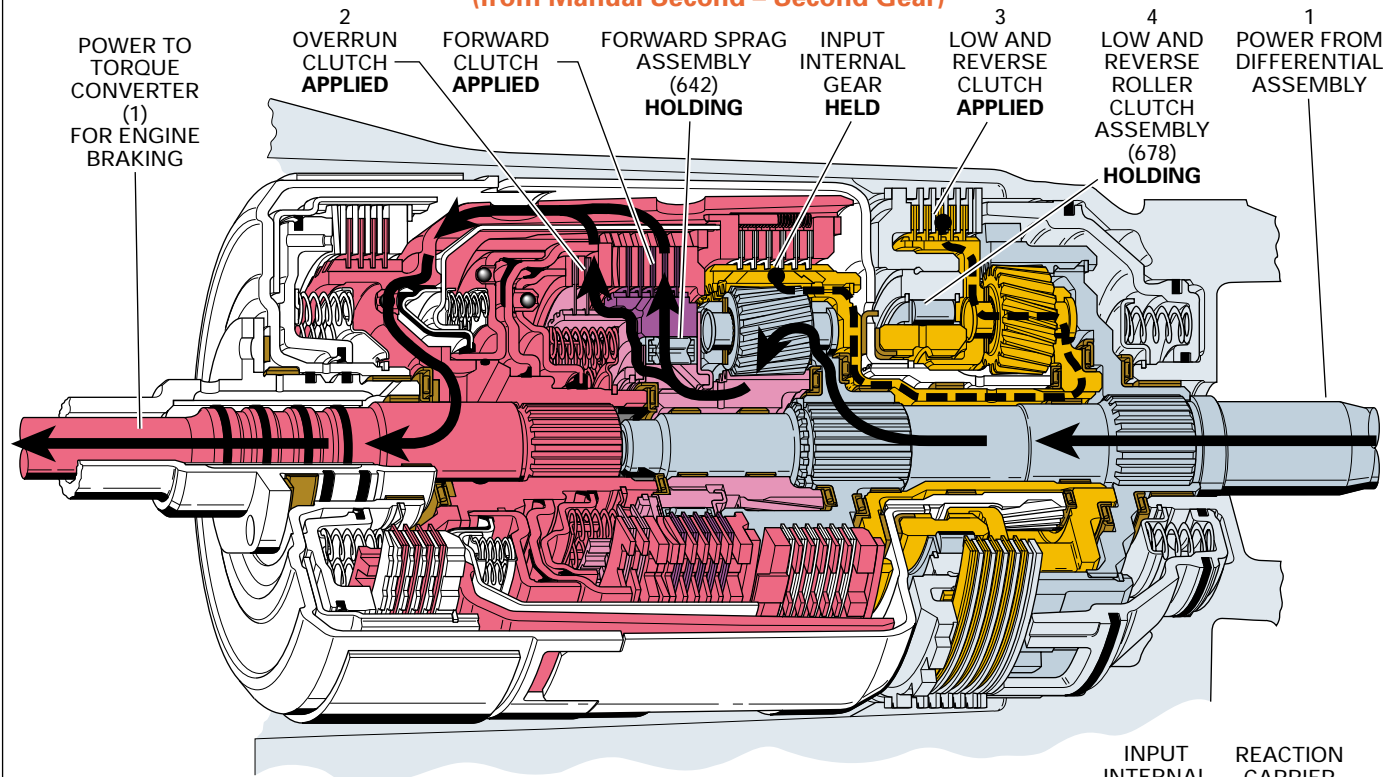

MANUAL FIRST – FIRST GEAR

(from Manual Second – Second Gear)

1-2 SHIFT SOLENOID VALVE	2-3 SHIFT SOLENOID VALVE	2-4 BAND	REVERSE INPUT CLUTCH	OVERRUN CLUTCH	FORWARD CLUTCH	FORWARD SPRAG CL. ASSEMBLY	3-4 CLUTCH	LO-ROLLER CLUTCH	LO/REV CLUTCH
ON	ON			APPLIED	APPLIED	HOLDING		HOLDING	APPLIED

Manual First is available to the driver when vehicle operating conditions require maximum engine compression braking for slowing the vehicle, or maximum engine torque transfer to the wheels. These conditions include: descending a steep grade to provide maximum engine compression braking and, to retain First gear when ascending a steep grade or pulling a heavy load for maximum engine power.

Under normal driving conditions, the transmission is prevented from upshifting while operating in Manual First. If the transmission is in any other forward gear range when Manual First is selected, the transmission will not shift into First gear until vehicle speed is below approximately 52 km/h (33 mph). Above this speed, the transmission will first shift into Second gear until vehicle speed slows sufficiently.

Note: Transfer of engine torque through the transmission during acceleration is identical to Overdrive Range – First Gear (refer to page 54A) to obtain an approximate gear ratio reduction of 3.06:1. The power flow in Figure 67 and the following text describes conditions during deceleration (zero or minimum throttle) and how engine compression braking is achieved.

Vehicle speed provides the torque input to the transmission through the drive shaft and transmission output shaft (687). This is shown by the direction of the power flow arrows in the drawing at the top of Figure 67. Notice that this flow is identical to Overdrive Range – First Gear except that the arrows are in the opposite direction.

1 Power From the Differential Assembly

Vehicle speed attempts to drive the input carrier assembly (662) faster than engine speed is driving the input housing and shaft assembly (621).

2 Overrun Clutch Applied

The overrun clutch plates (645) are applied and prevent the forward sprag clutch (642) from overrunning when the throttle is released.

3 Low and Reverse Clutch Applied

The low and reverse clutch plates (682) are applied in Manual First – First Gear. The low and reverse clutch holds the reaction carrier assembly (681) stationary to the transmission case.

4 Low and Reverse Roller Clutch Holding

With the reaction carrier held stationary, the low and reverse roller clutch (678) is prevented from being overrun when the throttle is released. Without an element to overrun during coast conditions, (either the sprag clutch or roller clutch), engine compression slows the vehicle when the throttle is released.

MANUAL FIRST – FIRST GEAR

(from Manual Second – Second Gear)

1-2 SHIFT SOLENOID VALVE	2-3 SHIFT SOLENOID VALVE	2-4 BAND	REVERSE INPUT CLUTCH	OVERRUN CLUTCH	FORWARD CLUTCH	FORWARD SPRAG CL. ASSEMBLY	3-4 CLUTCH	LO-ROLLER CLUTCH	LO/REV CLUTCH
ON	ON			APPLIED	APPLIED	HOLDING		HOLDING	APPLIED

Manual First (1) may be selected at any time while the vehicle is being operated in a forward gear range. However, the downshift to First gear is controlled electronically by the PCM which will not energize the 1-2 shift solenoid (SS) valve (First gear state) until the vehicle speed is below approximately 56 km/h (35 mph). Above this speed, the transmission will operate in a Manual First – Second Gear condition until vehicle speed slows sufficiently. Note that this speed varies depending on vehicle application.

When the gear selector lever is moved to Manual First, the manual valve also moves. With vehicle speed low enough, the following hydraulic and electrical changes occur to achieve Manual First – First Gear:

1 LOW AND REVERSE CLUTCH APPLIES

1a Manual Valve:

The selector lever moves the manual shaft and the manual valve into the manual first (1) position. This allows the line pressure to enter the lo fluid circuit.

1b TFP Manual Valve Position Switch:

Lo fluid is routed to the TFP manual valve position switch where it closes the normally open lo pressure switch. This signals to the PCM that manual first is selected.

1c 1-2 Shift Valve:

1-2 signal fluid pressure moves the valve into the downshifted position. In this position, Lo fluid from the manual valve is routed into the Lo/1st fluid circuit and D4 fluid is blocked from entering the 2nd fluid circuit. The 2nd fluid exhausts through an orifice and past the valve. This orifice (#26) helps control the 2-4 band release during a 2-1 downshift.

1d Lo Overrun Valve:

The Lo/1st fluid is regulated through the Lo Overrun valve and into the Lo/Reverse fluid circuit in order to control the Low and Reverse clutch apply.

1e Low and Reverse Piston:

The Lo/Reverse fluid pressure acts on the inner area of the piston in order to move the piston and to apply the Low and Reverse clutch plates.

2 2-4 BAND RELEASES

2a 1-2 Shift Solenoid (SS) Valve:

Below approximately 48 to 56 km/h (30 to 35 mph) the PCM energizes the normally open solenoid. This blocks the 1-2 signal fluid pressure from exhausting through the solenoid and creates pressure in the 1-2 signal fluid circuit.

2b 3-4 Shift Valve:

1-2 signal fluid pressure to the 3-4 shift valve is not enough to overcome the D3 fluid pressure or the 3-4 shift valve spring pressure.

2c 2nd & 4th Servo:

The 2nd clutch fluid, which was fed by the 2nd fluid, exhausts from the servo. This allows the spring force from the servo cushion and the servo return springs to move the 2nd apply piston and apply the pin to release the 2-4 band. These spring forces help control the 2-4 band release.

2d 3-2 Downshift Valve:

2nd clutch fluid exhausts from the 3-2 downshift valve. Exhausting 2nd clutch fluid unseats the 1-2 upshift ball check valve (#8) for a quick exhaust into the 2nd fluid circuit.

2e 2-3 Shift Valve Train:

Held in the downshifted position by the 2-3 signal fluid pressure from the solenoid, the valve train blocks the AFL fluid from entering the D432 fluid circuit.

2f 3-4 Relay Valve and 4-3 Sequence Valve:

2nd fluid exhausts from the 3-4 relay valve and servo feed fluid exhausts from the 4-3 sequence valve. Exhausting servo feed fluid is routed through the downshifted 2-3 shift valve and into the 2nd fluid circuit.

MANUAL FIRST – FIRST GEAR

(from Manual Second – Second Gear)

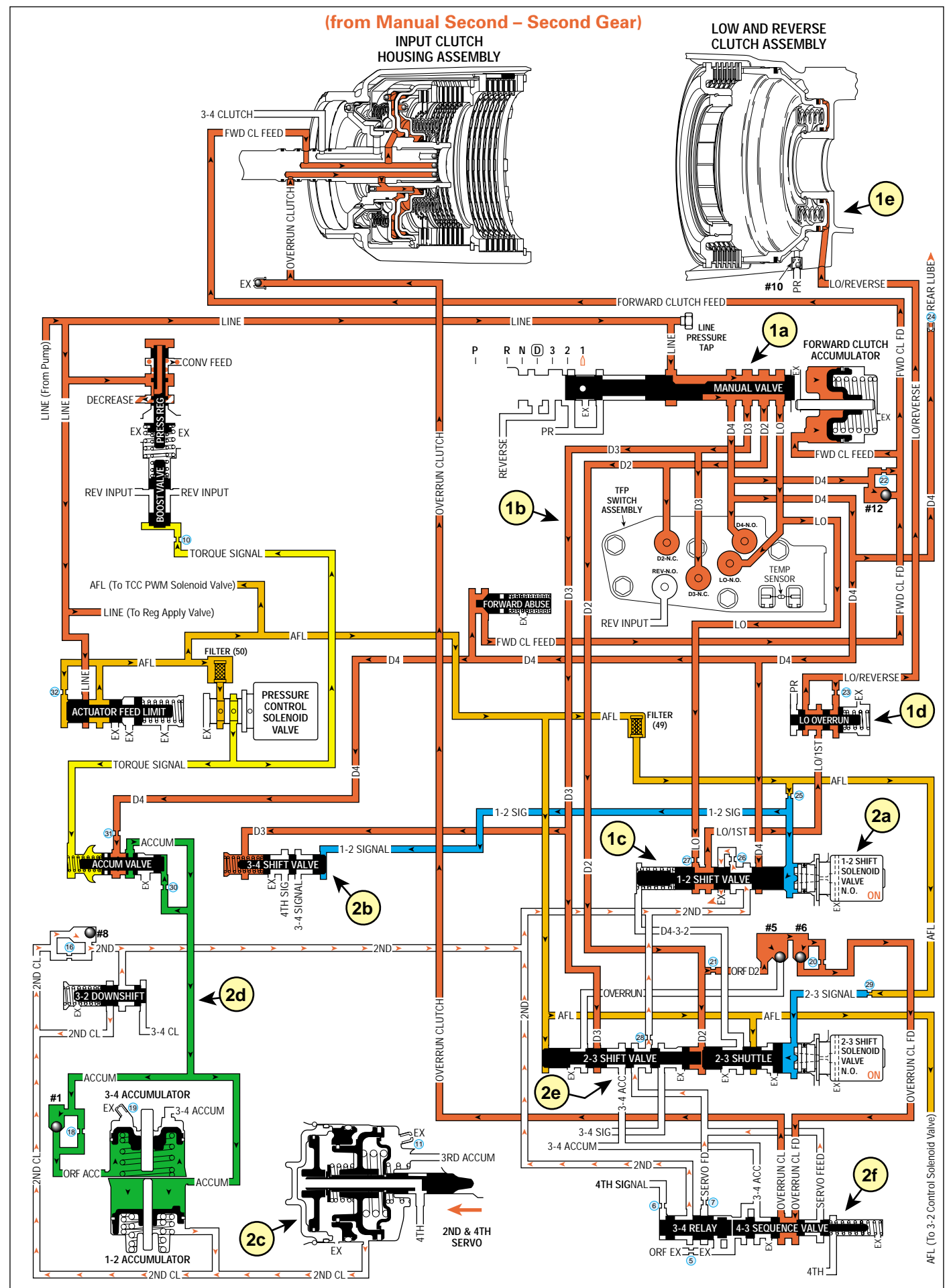

Figure 68

OPERATING CONDITIONS

RANGE REFERENCE CHART

RANGE	GEAR	SHIFT SOLENOID VALVES		2-4 BAND	REVERSE INPUT CLUTCH	OVERRUN CLUTCH	FORWARD CLUTCH	FORWARD SPRAG CL. ASSEMBLY	3-4 CLUTCH	LO ROLLER CLUTCH	LO/REV. CLUTCH
		1-2	2-3								
PARK		ON*	ON*								APPLIED
REVERSE		ON*	ON*		APPLIED						APPLIED
NEUTRAL		ON*	ON*								
D	1st	ON	ON				APPLIED	HOLDING		HOLDING	
	2nd	OFF	ON	APPLIED			APPLIED	HOLDING			
	3rd	OFF	OFF				APPLIED	HOLDING	APPLIED		
	4th	ON	OFF	APPLIED			APPLIED		APPLIED		
3	1st	ON	ON				APPLIED	HOLDING		HOLDING	
	2nd	OFF	ON	APPLIED			APPLIED	HOLDING			
	3rd	OFF	OFF			APPLIED	APPLIED	HOLDING	APPLIED		
2 ***	1st **	ON	ON			APPLIED	APPLIED	HOLDING		HOLDING	
	2nd	OFF	ON	APPLIED		APPLIED	APPLIED	HOLDING			
1 ***	1st	ON	ON			APPLIED	APPLIED	HOLDING		HOLDING	APPLIED
	2nd	OFF	ON	APPLIED		APPLIED	APPLIED	HOLDING			

* 1-2 AND 2-3 SHIFT SOLENOID OPERATION AND THE SHIFT VALVE POSITIONING IN P, R, N RANGES ARE A FUNCTION OF THE INPUT TO THE SOLENOIDS FROM THE VSS. UNDER NORMAL OPERATING CONDITIONS THE SOLENOIDS ARE ON IN P, R, N.

** A MANUAL SECOND - FIRST GEAR CONDITION IS ONLY AVAILABLE ON SOME MODELS. OTHERWISE, THIS CONDITION IS ELECTRONICALLY PREVENTED.

*** IN MANUAL SECOND AND MANUAL FIRST, SOLENOID OPERATION IS A RESULT OF PCM CALIBRATION. SOME CALIBRATIONS WILL ALLOW ALL THREE GEARS UNDER EXTREME CONDITIONS.

ON = SOLENOID ENERGIZED
OFF = SOLENOID DE-ENERGIZED

NOTE: DESCRIPTIONS ABOVE EXPLAIN COMPONENT FUNCTION DURING ACCELERATION.

EXPECTED OPERATING CONDITION IF COMPONENT IN COLUMN NUMBER IS INOPERATIVE:

COLUMN #	CONDITION
1	NO 2ND, NO 4TH GEAR.
2	NO REVERSE.
3	NO ENGINE BRAKING IN MANUAL 2ND, MANUAL 1ST, AND MANUAL 3RD (3RD GEAR).
4	NO FORWARD IN D AND MANUAL 3RD.
5	NO FORWARD IN D AND MANUAL 3RD.
6	NO 3RD GEAR, NO 4TH GEAR.
7	NO 1ST GEAR IN D, MANUAL 3RD, AND MANUAL 2ND.
8	NO REVERSE, NO ENGINE BRAKING IN MANUAL 1ST.

SHIFT SOLENOID VALVE ELECTRICAL CONDITIONS

If the PCM detects a continuous open or short to ground in the shift solenoids or shift solenoid circuits the following actions occur:

- | | |
|-------|--|
| 1-2 | • The PCM commands maximum line pressure. |
| DTC | • The PCM disables shift adapts. |
| P0753 | • The PCM inhibits downshifts to 2nd gear if the vehicle speed is greater than 48 km/h (30 mph). |
| | • The PCM illuminates the Malfunction Indicator Lamp (MIL). |
| | |
| 2-3 | • The PCM commands maximum line pressure. |
| DTC | • The PCM disables shift adapts. |
| P0758 | • The PCM commands 2nd gear. |
| | • The PCM illuminates the Malfunction Indicator Lamp (MIL). |

COMPLETE HYDRAULIC CIRCUITS

The hydraulic circuitry of the Hydra-matic 4L60-E transmission is better understood when fluid flow can be related to the specific components in which the fluid travels. In the Power Flow section, a simplified hydraulic schematic was given to show what hydraulically occurs in a specific gear range. The purpose was to isolate the hydraulics used in each gear range in order to provide the user with a basic understanding of the hydraulic system.

In contrast, this section shows a complete hydraulic schematic with fluid passages active in the appropriate component for each gear range. This is accomplished using two opposing foldout pages that are separated by a half page of supporting information.

The left side foldout contains the complete color coded hydraulic circuit for the given gear range along with the relative location of valves,

checkballs and orifices within specific components. A broken line is also used to separate components such as the pump, valve body and case to assist the user when following the hydraulic circuits as they pass between them. Also, the numbers shown in the circuits at the broken lines reference specific holes and orifices in the spacer plate on the right hand foldout. The half page of information facing this foldout identifies the components involved in this gear range and a description of how they function.

The right side foldout shows a two-dimensional line drawing of the fluid passages within each component. The active fluid passages for each gear range are appropriately colored to correspond with the hydraulic schematic used for that range. The half page of information facing this foldout identifies the various fluid circuits with numbers that correspond to the circuit numbers used on the foldout page.

- PASSAGE A IS LOCATED IN THE PUMP BODY (LIGHT GREY AREA)
- PASSAGE B IS LOCATED IN THE VALVE BODY (LIGHT BLUE AREA)
- PASSAGE C IS LOCATED ON THE SPACER PLATE (DASHED LINE)
- PASSAGE D IS LOCATED IN CASE (WHITE AREA)
- PASSAGE E IS LOCATED IN THE ACCUMULATOR HOUSING (LIGHT YELLOW AREA)

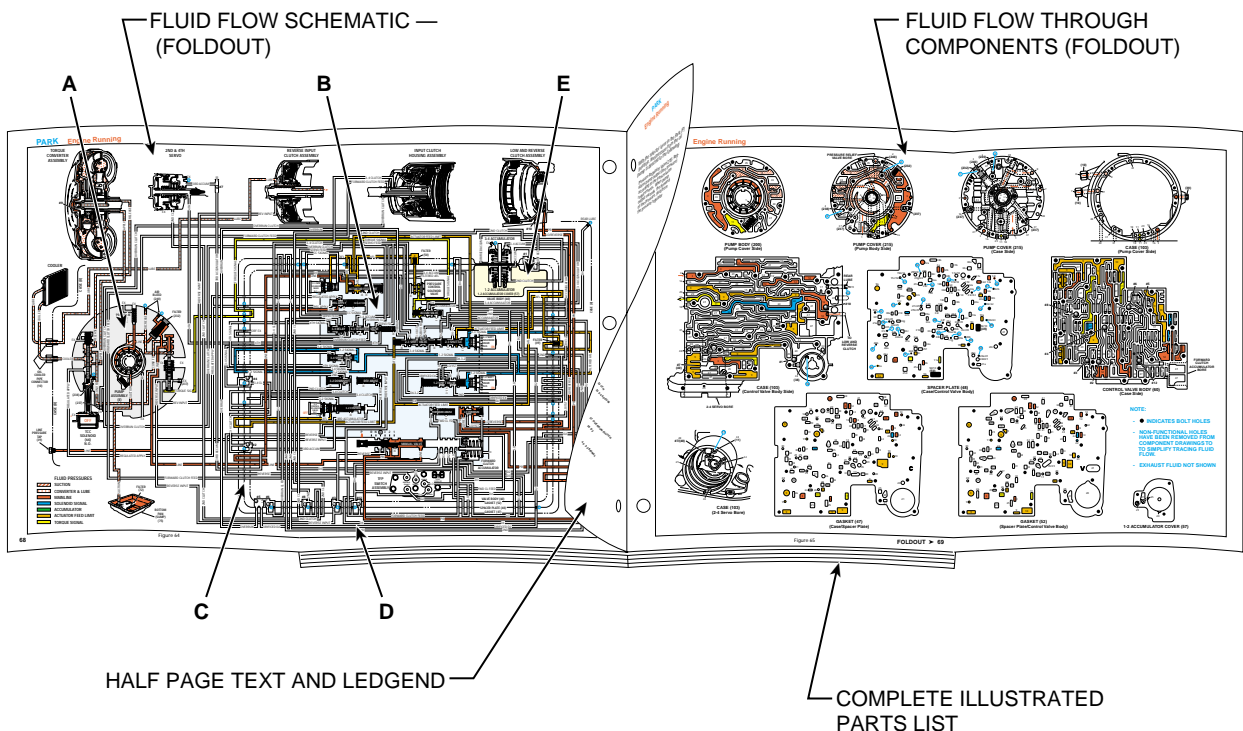

Figure 70

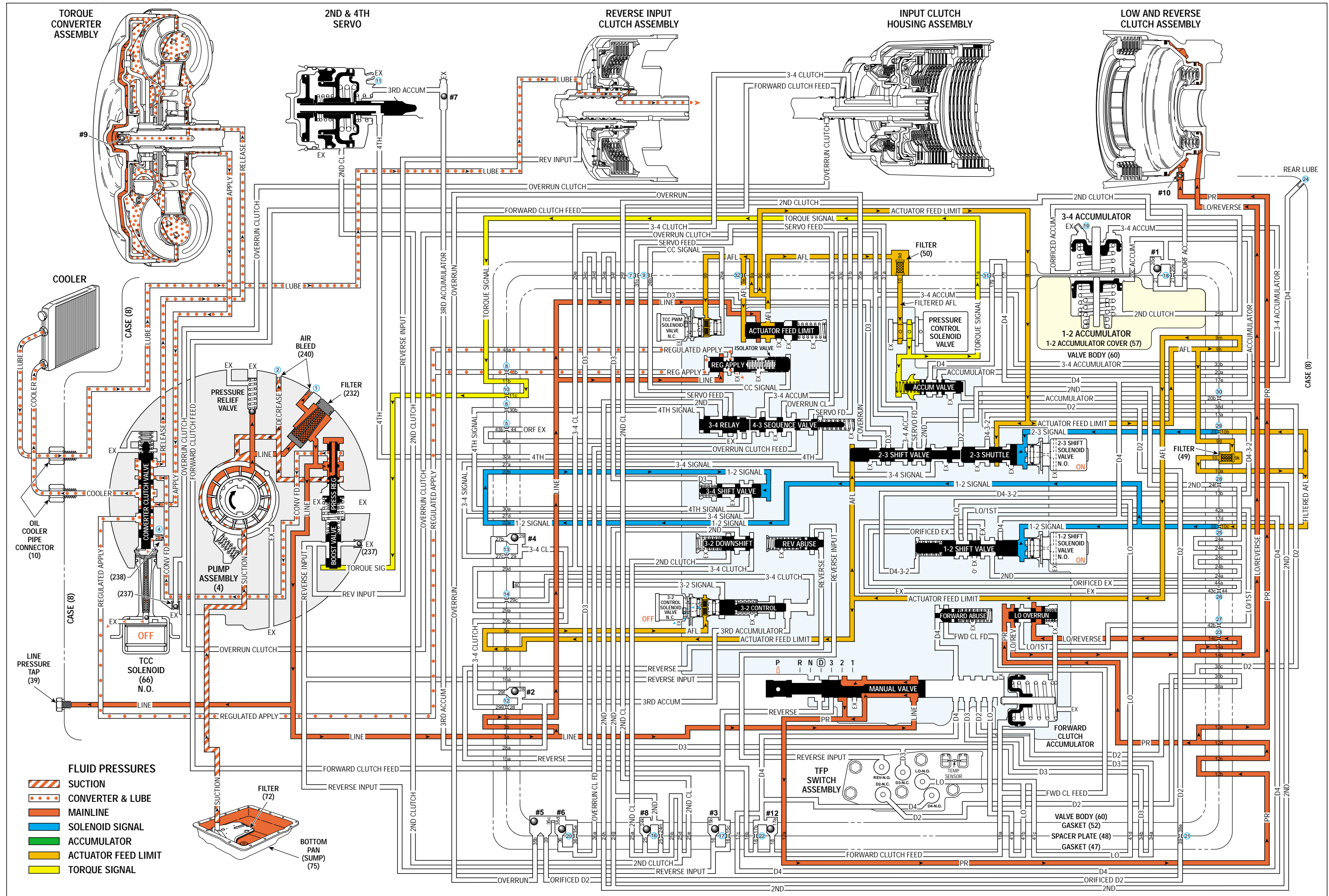

Figure 71

PARK (Engine Running)

The following conditions and component problems could happen in any gear range, and are only some of the possibilities recommended to diagnose hydraulic problems. Always refer to the appropriate vehicle platform service manual when diagnosing specific concerns.

HIGH LINE PRESSURE

- Pressure Regulator Valve (216), or Reverse Boost Valve (219)
 - Stuck, damaged
- 2-3 Shift Valve (368)
 - Stuck
- Pressure Relief Ball (228)
 - Not seated or damaged.
- Pressure Control Solenoid Valve (377)
 - Damage to pins.

LOW LINE PRESSURE

- Pressure Regulator Valve (216), Boost Valve (219), or Spring (217)
 - Stuck, damaged, broken
- Oil Pump (200)
 - Cross channel air leak, body to cover or body to case
- Pump Valve Bores
 - Excessive valve clearance due to wear
- Valve Body (350)
 - Cross channel leaks
 - Cross valve land leaks
- Gasket/Spacer Plate
 - Damaged
 - Missing
- Pressure Control Solenoid Valve (377)
 - Valve is stuck On
 - Broken clip causes leakage
 - Wire is pinched to ground
 - Screen is missing
- Cooler Lines
 - Clogged or restricted.

1-2 SHIFT SOLENOID VALVE	2-3 SHIFT SOLENOID VALVE	2-4 BAND	REVERSE INPUT CLUTCH	OVERRUN CLUTCH	FORWARD CLUTCH	FORWARD SPRAG CL. ASSEMBLY	3-4 CLUTCH	LO-ROLLER CLUTCH	LO/REV CLUTCH
ON	ON								APPLIED

PASSAGES

- 1 SUCTION
- 2 DECREASE
- 3 LINE
- 4 CONVERTER FEED
- 5 RELEASE
- 6 APPLY
- 7 COOLER
- 8 LUBE
- 9 ACTUATOR FEED LIMIT
- 10 FILTERED ACTUATOR FEED
- 11 TORQUE SIGNAL
- 12 PR
- 13 D4-3-2
- 14 LO/REVERSE
- 15 REVERSE
- 16 REVERSE INPUT
- 17 D4
- 18 FORWARD CLUTCH FEED
- 19 REAR LUBE
- 20 ACCUMULATOR
- 21 ORIFICED ACCUMULATOR
- 22 1-2 SIGNAL
- 23 2-3 SIGNAL
- 24 2ND
- 25 2ND CLUTCH
- 26 C. C. SIGNAL
- 27 3-4 SIGNAL
- 28 3RD ACCUMULATOR
- 29 3-4 CLUTCH
- 30 4TH SIGNAL
- 31 SERVO FEED
- 32 4TH
- 33 3-4 ACCUMULATOR
- 34 D3
- 35 OVERRUN
- 36 OVERRUN CLUTCH FEED
- 37 OVERRUN CLUTCH
- 38 D2
- 39 ORIFICED D2
- 40 3-2 SIGNAL
- 41 LO
- 42 LO/1ST
- 43 EXHAUST
- 44 ORIFICED EXHAUST
- 45 VENT
- 46 SEAL DRAIN
- 47 VOID
- 48 REGULATED APPLY

COMPONENTS ()

- (8) REAR LUBE (ORIFICED CUP PLUG/REAR CASE)
- (10) OIL COOLER PIPE CONNECTOR
- (11) CASE SERVO ORIFICED PLUG
- (38) ACCUMULATOR BLEED PLUG
- (39) LINE PRESSURE TAP
- (40) 3RD ACCUM. RETAINER AND BALL ASSEMBLY (#7)
- (49) SHIFT SOLENOIDS SCREEN
- (50) PRESSURE CONTROL SOLENOID SCREEN
- (61) CHECKBALLS (#1, 2, 3, 4, 5, 6, 8, 12)
- (91) CHECKBALL (#10)
- (232) OIL PUMP COVER SCREEN
- (237) CHECK VALVE RETAINER AND BALL ASSEMBLY
- (238) CONVERTER CLUTCH SIGNAL ORIFICED CUP PLUG
- (240) ORIFICED CUP PLUG

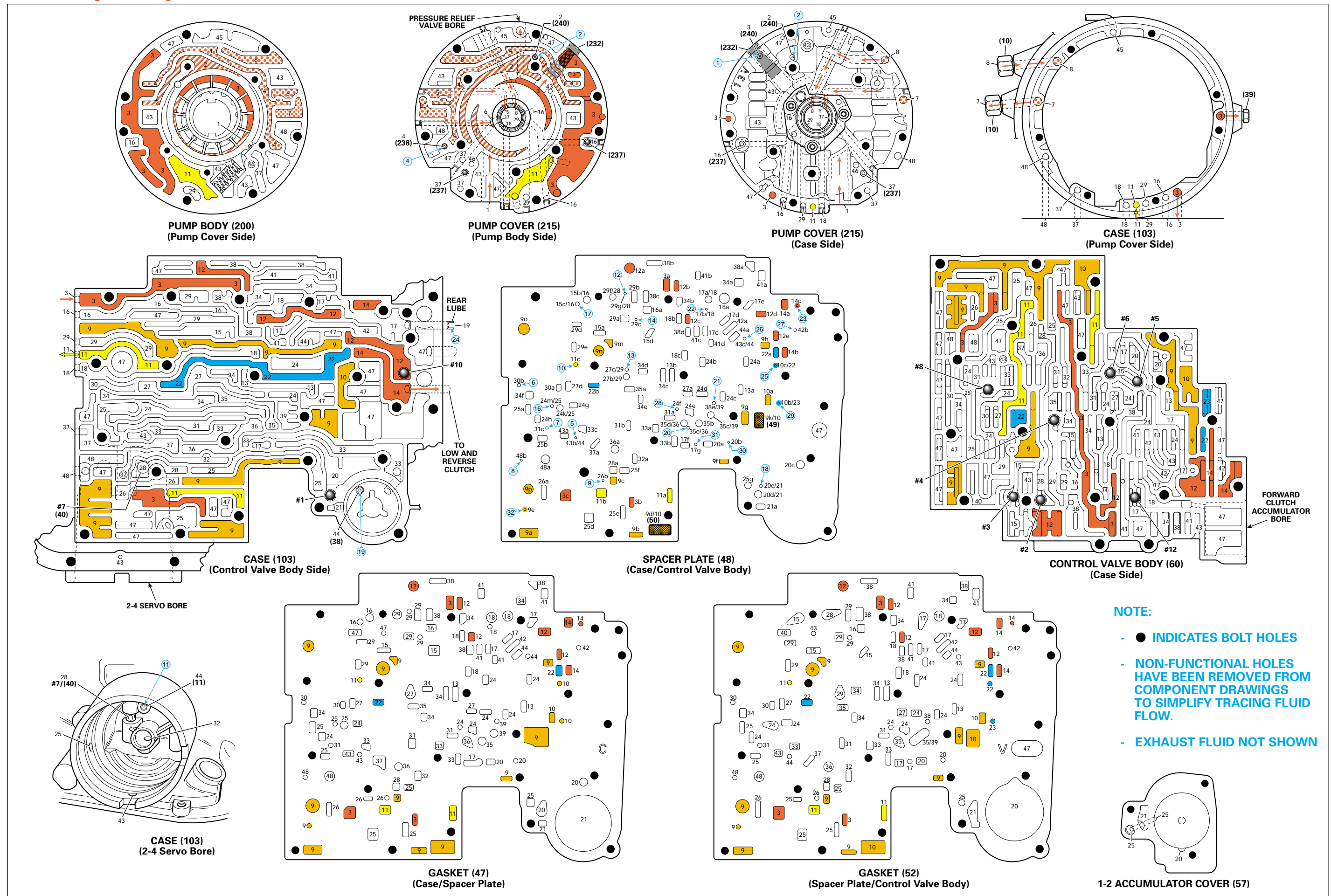
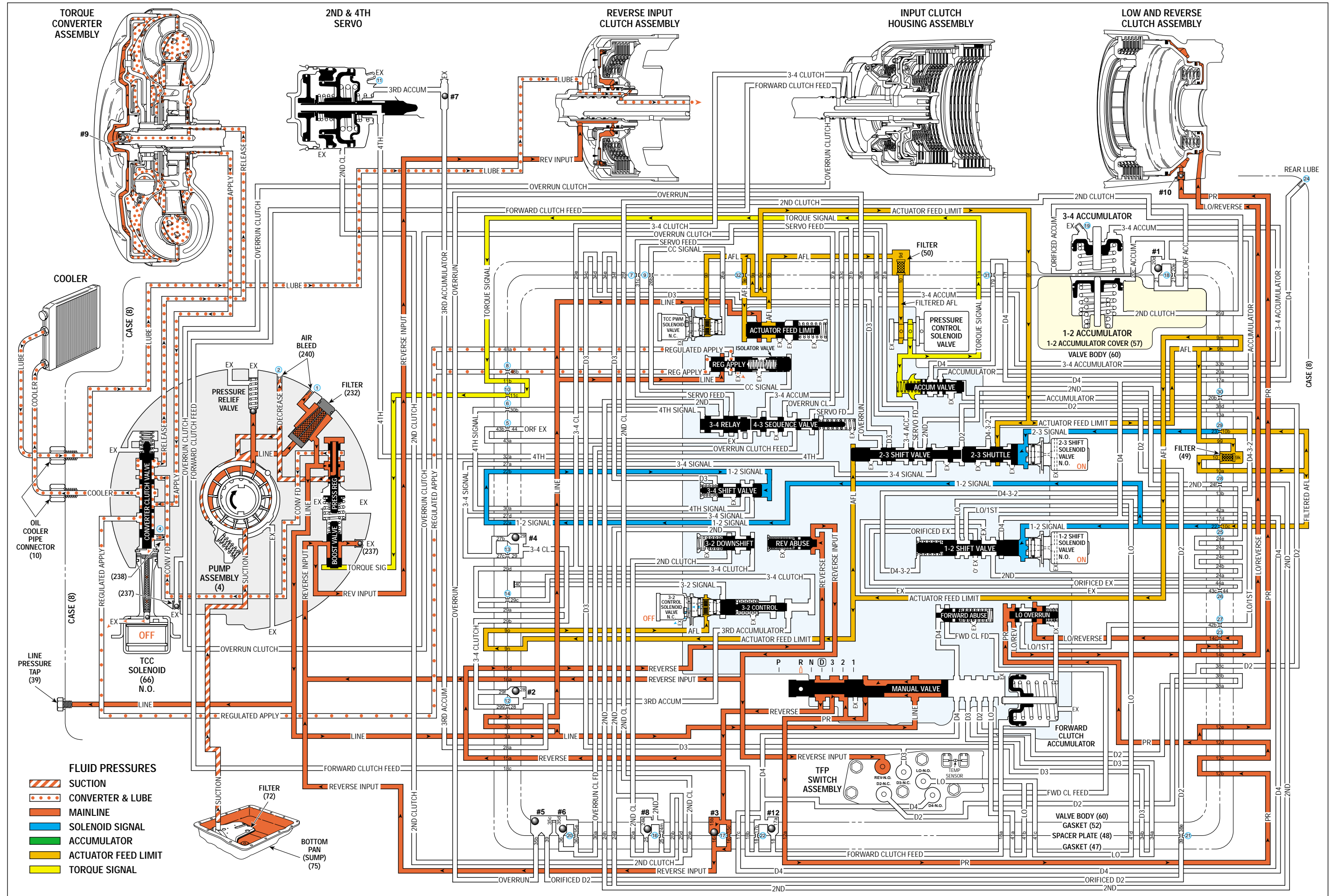

Figure 72



REVERSE

NO REVERSE OR SLIPS IN REVERSE

- Turbine Shaft Seal (618)
 - Missing, cut or damaged
- 2-3 Shift Valve (368)
 - Stuck
- Low Overrun Valve (361)
 - Stuck
- Orificed Cup Plug (240)
 - Restricted, missing or damaged
- Reverse Input Housing and Drum Assembly (605)
 - Cracked at weld
- Reverse Input Clutch Plate Retaining Ring (614)
 - Out of groove
- Reverse Input Clutch Belleville Plate (611)
 - Installed incorrectly
- Low and Reverse Clutch Piston (695)
 - Porosity

ENGINE STALLS IN REVERSE

- Cooler Lines
 - Pinched

1-2 SHIFT SOLENOID VALVE	2-3 SHIFT SOLENOID VALVE	2-4 BAND	REVERSE INPUT CLUTCH	OVERRUN CLUTCH	FORWARD CLUTCH	FORWARD SPRAG CL. ASSEMBLY	3-4 CLUTCH	LO-ROLLER CLUTCH	LO/REV CLUTCH
ON	ON		APPLIED						APPLIED

PASSAGES

- 1 SUCTION
- 2 DECREASE
- 3 LINE
- 4 CONVERTER FEED
- 5 RELEASE
- 6 APPLY
- 7 COOLER
- 8 LUBE
- 9 ACTUATOR FEED LIMIT
- 10 FILTERED ACTUATOR FEED
- 11 TORQUE SIGNAL
- 12 PR
- 13 D4-3-2
- 14 LO/REVERSE
- 15 REVERSE
- 16 REVERSE INPUT
- 17 D4
- 18 FORWARD CLUTCH FEED
- 19 REAR LUBE
- 20 ACCUMULATOR
- 21 ORIFICED ACCUMULATOR
- 22 1-2 SIGNAL
- 23 2-3 SIGNAL
- 24 2ND
- 25 2ND CLUTCH
- 26 C. C. SIGNAL
- 27 3-4 SIGNAL
- 28 3RD ACCUMULATOR
- 29 3-4 CLUTCH
- 30 4TH SIGNAL
- 31 SERVO FEED
- 32 4TH
- 33 3-4 ACCUMULATOR
- 34 D3
- 35 OVERRUN
- 36 OVERRUN CLUTCH FEED
- 37 OVERRUN CLUTCH
- 38 D2
- 39 ORIFICED D2
- 40 3-2 SIGNAL
- 41 LO
- 42 LO/1ST
- 43 EXHAUST
- 44 ORIFICED EXHAUST
- 45 VENT
- 46 SEAL DRAIN
- 47 VOID
- 48 REGULATED APPLY

COMPONENTS ()

- (8) REAR LUBE (ORIFICED CUP PLUG/REAR CASE)
- (10) OIL COOLER PIPE CONNECTOR
- (11) CASE SERVO ORIFICED PLUG
- (38) ACCUMULATOR BLEED PLUG
- (39) LINE PRESSURE TAP
- (40) 3RD ACCUM. RETAINER AND BALL ASSEMBLY (#7)
- (49) SHIFT SOLENOIDS SCREEN
- (50) PRESSURE CONTROL SOLENOID SCREEN
- (61) CHECKBALLS (#1, 2, 3, 4, 5, 6, 8, 12)
- (91) CHECKBALL (#10)
- (232) OIL PUMP COVER SCREEN
- (237) CHECK VALVE RETAINER AND BALL ASSEMBLY
- (238) CONVERTER CLUTCH SIGNAL ORIFICED CUP PLUG
- (240) ORIFICED CUP PLUG

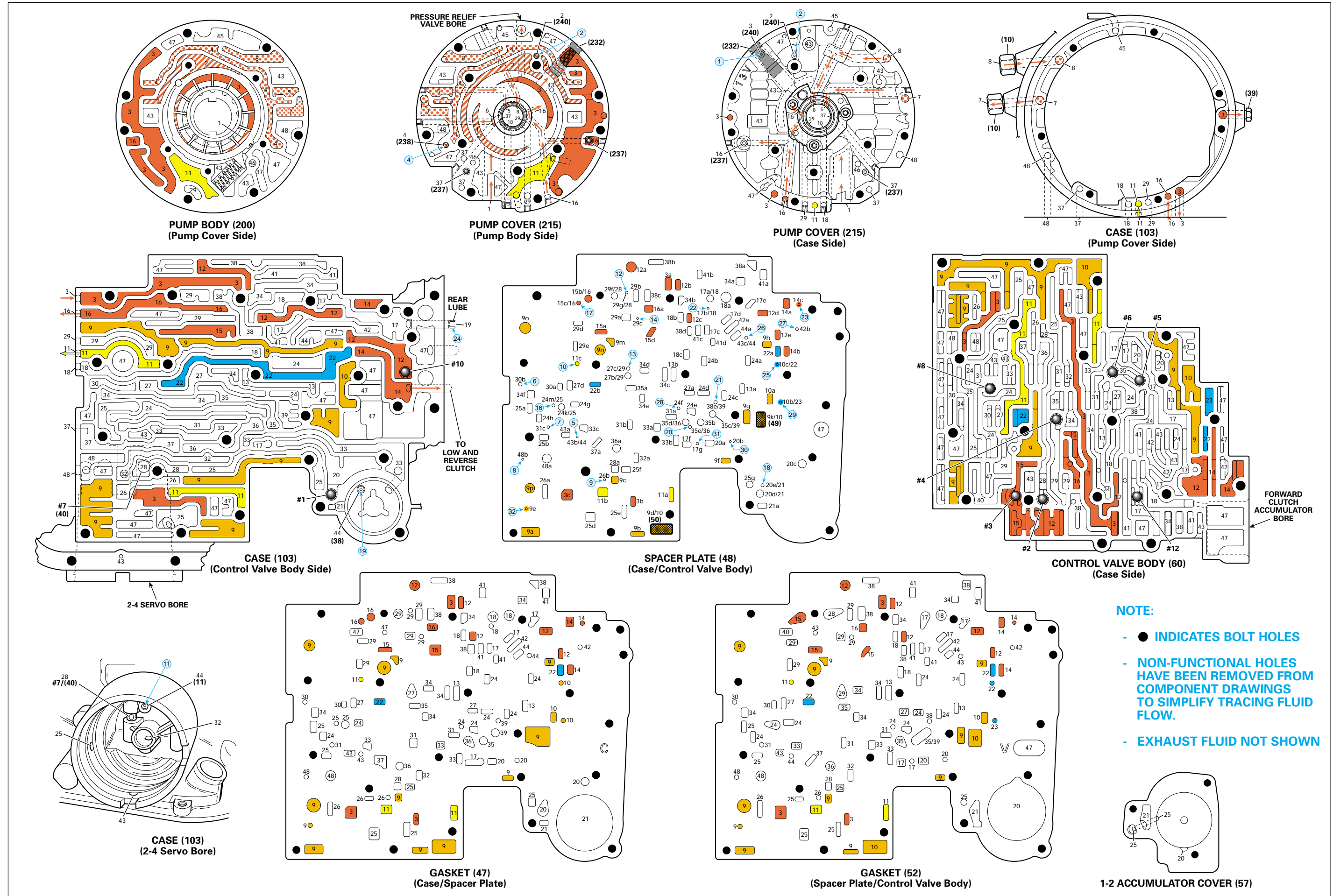

Figure 74

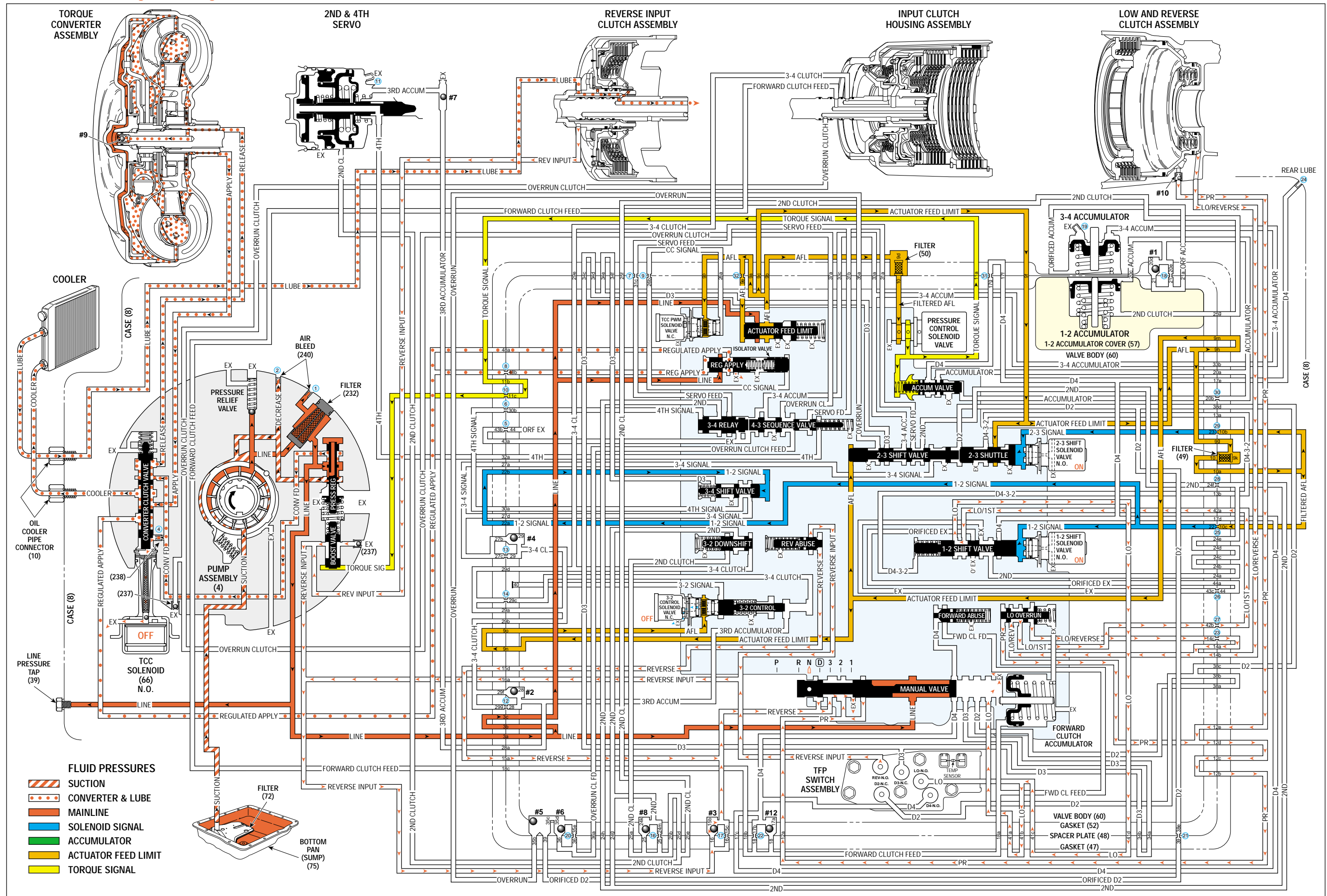

Figure 75

NEUTRAL

(Engine Running)

DRIVES IN NEUTRAL

- Forward Clutch
 - The clutch does not release.
- Manual Valve Link (89)
 - Disconnected
- Case (103)
 - The face is not flat.
 - Internal leakage exists

ENGINE STALLS IN NEUTRAL

- TCC System
 - Stuck On or dragging

1-2 SHIFT SOLENOID VALVE	2-3 SHIFT SOLENOID VALVE	2-4 BAND	REVERSE INPUT CLUTCH	OVERRUN CLUTCH	FORWARD CLUTCH	FORWARD SPRAG CL. ASSEMBLY	3-4 CLUTCH	LO-ROLLER CLUTCH	LO/REV CLUTCH
ON	ON								

NEUTRAL

(Engine Running)

PASSAGES

- 1 SUCTION
- 2 DECREASE
- 3 LINE
- 4 CONVERTER FEED
- 5 RELEASE
- 6 APPLY
- 7 COOLER
- 8 LUBE
- 9 ACTUATOR FEED LIMIT
- 10 FILTERED ACTUATOR FEED
- 11 TORQUE SIGNAL
- 12 PR
- 13 D4-3-2
- 14 LO/REVERSE
- 15 REVERSE
- 16 REVERSE INPUT
- 17 D4
- 18 FORWARD CLUTCH FEED
- 19 REAR LUBE
- 20 ACCUMULATOR
- 21 ORIFICED ACCUMULATOR
- 22 1-2 SIGNAL
- 23 2-3 SIGNAL
- 24 2ND
- 25 2ND CLUTCH
- 26 C. C. SIGNAL
- 27 3-4 SIGNAL
- 28 3RD ACCUMULATOR
- 29 3-4 CLUTCH
- 30 4TH SIGNAL
- 31 SERVO FEED
- 32 4TH
- 33 3-4 ACCUMULATOR
- 34 D3
- 35 OVERRUN
- 36 OVERRUN CLUTCH FEED
- 37 OVERRUN CLUTCH
- 38 D2
- 39 ORIFICED D2
- 40 3-2 SIGNAL
- 41 LO
- 42 LO/1ST
- 43 EXHAUST
- 44 ORIFICED EXHAUST
- 45 VENT
- 46 SEAL DRAIN
- 47 VOID
- 48 REGULATED APPLY

COMPONENTS ()

- (8) REAR LUBE (ORIFICED CUP PLUG/REAR CASE)
- (10) OIL COOLER PIPE CONNECTOR
- (11) CASE SERVO ORIFICED PLUG
- (38) ACCUMULATOR BLEED PLUG
- (39) LINE PRESSURE TAP
- (40) 3RD ACCUM. RETAINER AND BALL ASSEMBLY (#7)
- (49) SHIFT SOLENOIDS SCREEN
- (50) PRESSURE CONTROL SOLENOID SCREEN
- (61) CHECKBALLS (#1, 2, 3, 4, 5, 6, 8, 12)
- (91) CHECKBALL (#10)
- (232) OIL PUMP COVER SCREEN
- (237) CHECK VALVE RETAINER AND BALL ASSEMBLY
- (238) CONVERTER CLUTCH SIGNAL ORIFICED CUP PLUG
- (240) ORIFICED CUP PLUG

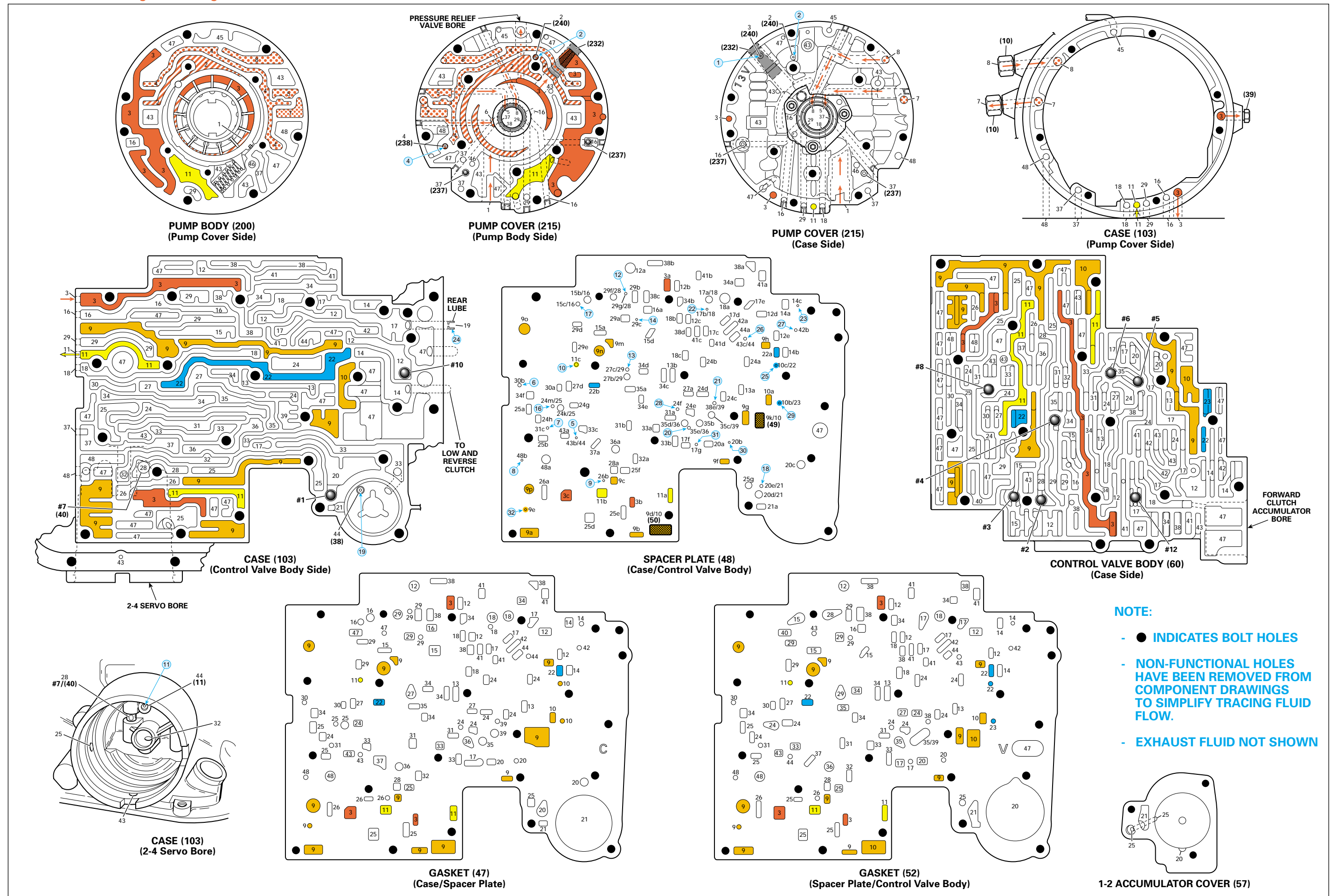

Figure 76

OVERDRIVE RANGE – FIRST GEAR

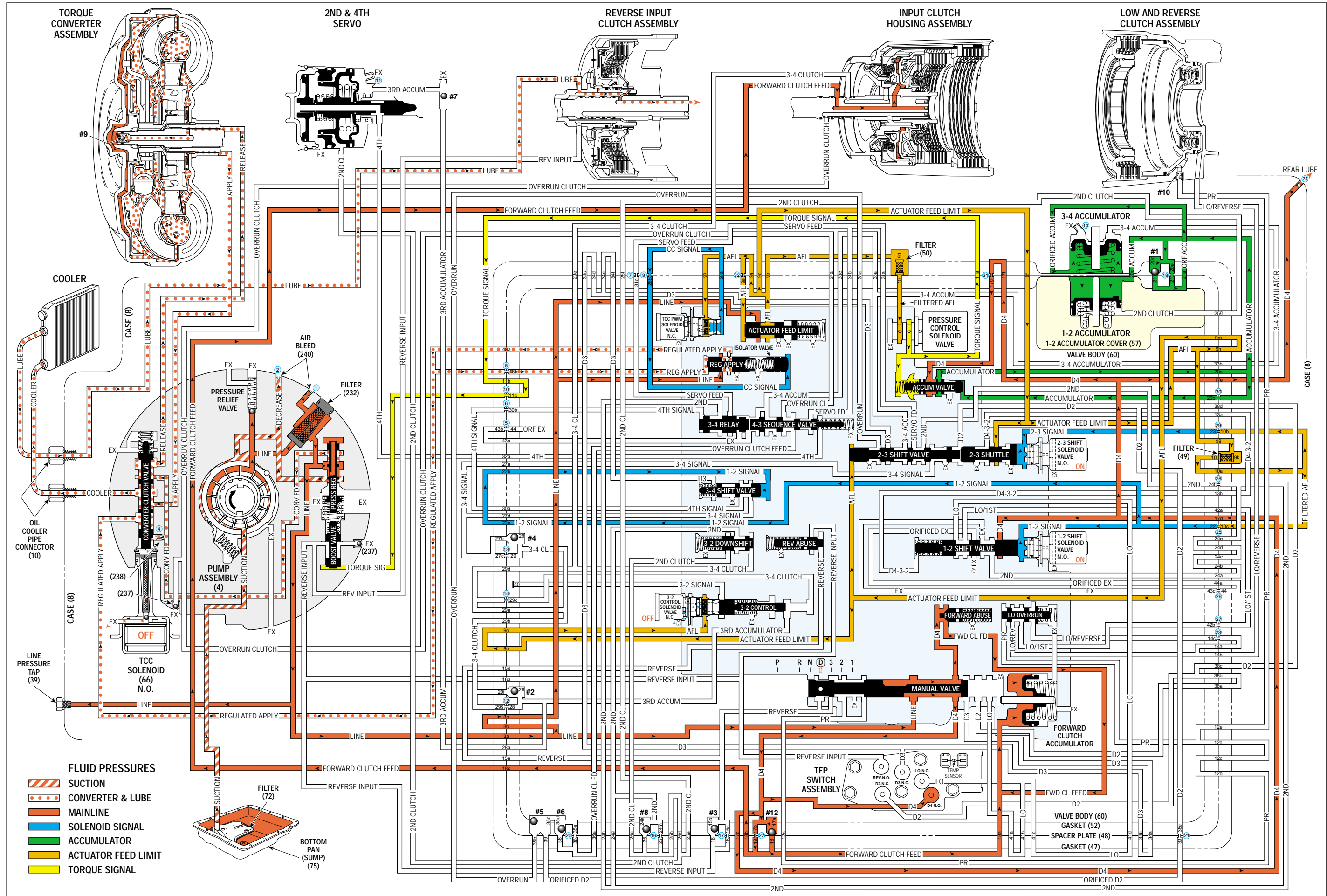

Figure 77

OVERDRIVE RANGE – FIRST GEAR

1ST GEAR RANGE ONLY - NO UPSHIFT

- Valve Body Spacer Plate (48)
 - Mispositioned or damaged
- Shift Solenoid Valves (379)
 - Stuck or damaged
 - Faulty electrical connection
- 2-4 Band (602)
 - Worn or damaged

SLIPS IN 1ST GEAR

- Forward Clutch Housing (628)
 - Damaged
- 1-2 Accumulator Valve (371)
 - Stuck
- Torque Converter (1)
 - Stator roller clutch not holding

1-2 SHIFT SOLENOID VALVE	2-3 SHIFT SOLENOID VALVE	2-4 BAND	REVERSE INPUT CLUTCH	OVERRUN CLUTCH	FORWARD CLUTCH	FORWARD SPRAG CL ASSEMBLY	3-4 CLUTCH	LO-ROLLER CLUTCH	LO/REV CLUTCH
ON	ON				APPLIED	HOLDING		HOLDING	

OVERDRIVE RANGE – FIRST GEAR

PASSAGES

- 1 SUCTION
- 2 DECREASE
- 3 LINE
- 4 CONVERTER FEED
- 5 RELEASE
- 6 APPLY
- 7 COOLER
- 8 LUBE
- 9 ACTUATOR FEED LIMIT
- 10 FILTERED ACTUATOR FEED
- 11 TORQUE SIGNAL
- 12 PR
- 13 D4-3-2
- 14 LO/REVERSE
- 15 REVERSE
- 16 REVERSE INPUT
- 17 D4
- 18 FORWARD CLUTCH FEED
- 19 REAR LUBE
- 20 ACCUMULATOR
- 21 ORIFICED ACCUMULATOR
- 22 1-2 SIGNAL
- 23 2-3 SIGNAL
- 24 2ND
- 25 2ND CLUTCH
- 26 C. C. SIGNAL
- 27 3-4 SIGNAL
- 28 3RD ACCUMULATOR
- 29 3-4 CLUTCH
- 30 4TH SIGNAL
- 31 SERVO FEED
- 32 4TH
- 33 3-4 ACCUMULATOR
- 34 D3
- 35 OVERRUN
- 36 OVERRUN CLUTCH FEED
- 37 OVERRUN CLUTCH
- 38 D2
- 39 ORIFICED D2
- 40 3-2 SIGNAL
- 41 LO
- 42 LO/1ST
- 43 EXHAUST
- 44 ORIFICED EXHAUST
- 45 VENT
- 46 SEAL DRAIN
- 47 VOID
- 48 REGULATED APPLY

COMPONENTS ()

- (8) REAR LUBE (ORIFICED CUP PLUG/REAR CASE)
- (10) OIL COOLER PIPE CONNECTOR
- (11) CASE SERVO ORIFICED PLUG
- (38) ACCUMULATOR BLEED PLUG
- (39) LINE PRESSURE TAP
- (40) 3RD ACCUM. RETAINER AND BALL ASSEMBLY (#7)
- (49) SHIFT SOLENOIDS SCREEN
- (50) PRESSURE CONTROL SOLENOID SCREEN
- (61) CHECKBALLS (#1, 2, 3, 4, 5, 6, 8, 12)
- (91) CHECKBALL (#10)
- (232) OIL PUMP COVER SCREEN
- (237) CHECK VALVE RETAINER AND BALL ASSEMBLY
- (238) CONVERTER CLUTCH SIGNAL ORIFICED CUP PLUG
- (240) ORIFICED CUP PLUG

OVERDRIVE RANGE - FIRST GEAR

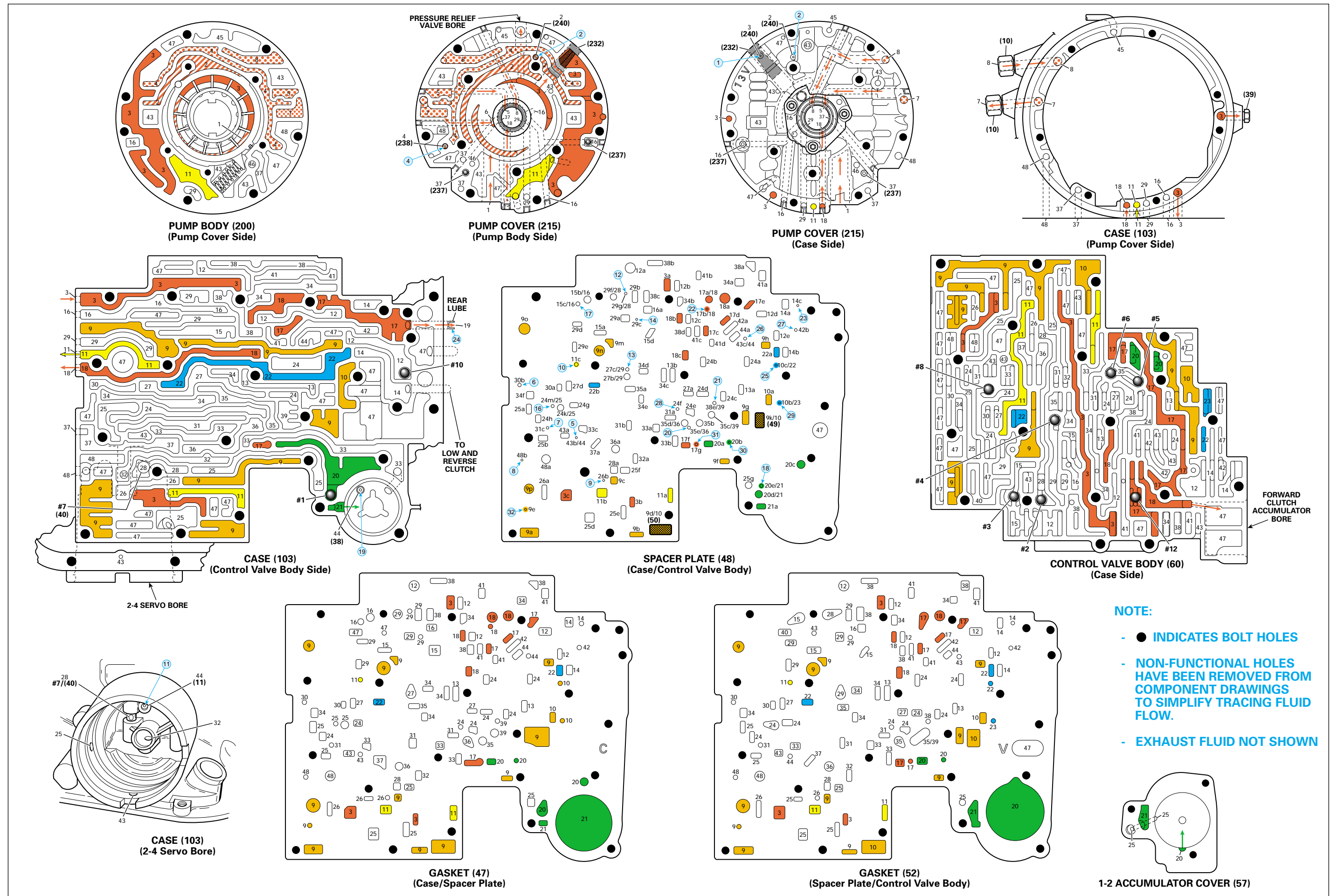

Figure 78

OVERDRIVE RANGE – SECOND GEAR

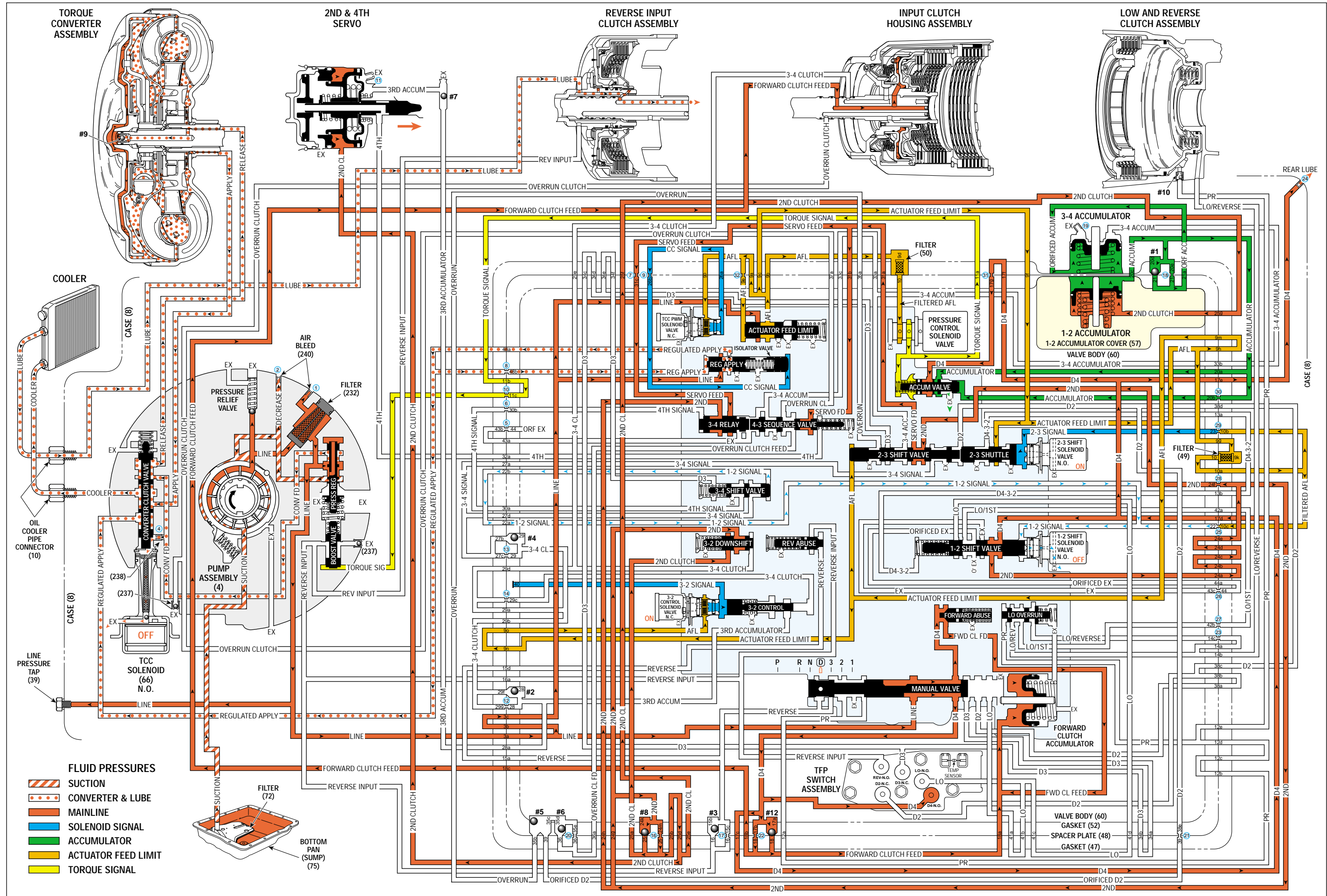

Figure 79

OVERDRIVE RANGE – SECOND GEAR

SLIPPING OR ROUGH 1-2 SHIFT

- 1-2 Accumulator Valve (371)
 - Stuck
- 2nd Apply Piston Pin (13)
 - Too long or too short
- 1-2 Accumulator Housing (57)
 - Nicks or burrs

2ND GEAR STARTS

- Forward Clutch Sprag Assembly (642)
 - Installed backwards

1-2 SHIFT SOLENOID VALVE	2-3 SHIFT SOLENOID VALVE	2-4 BAND	REVERSE INPUT CLUTCH	VERRUN CLUTCH	FORWARD CLUTCH	FORWARD SPRAG CL ASSEMBLY	3-4 CLUTCH	LO-ROLLER CLUTCH	LO/REV CLUTCH
OFF	ON	APPLIED			APPLIED	HOLDING			

OVERDRIVE RANGE – SECOND GEAR

PASSAGES

- 1 SUCTION
- 2 DECREASE
- 3 LINE
- 4 CONVERTER FEED
- 5 RELEASE
- 6 APPLY
- 7 COOLER
- 8 LUBE
- 9 ACTUATOR FEED LIMIT
- 10 FILTERED ACTUATOR FEED
- 11 TORQUE SIGNAL
- 12 PR
- 13 D4-3-2
- 14 LO/REVERSE
- 15 REVERSE
- 16 REVERSE INPUT
- 17 D4
- 18 FORWARD CLUTCH FEED
- 19 REAR LUBE
- 20 ACCUMULATOR
- 21 ORIFICED ACCUMULATOR
- 22 1-2 SIGNAL
- 23 2-3 SIGNAL
- 24 2ND
- 25 2ND CLUTCH
- 26 C. C. SIGNAL
- 27 3-4 SIGNAL
- 28 3RD ACCUMULATOR
- 29 3-4 CLUTCH
- 30 4TH SIGNAL
- 31 SERVO FEED
- 32 4TH
- 33 3-4 ACCUMULATOR
- 34 D3
- 35 OVERRUN
- 36 OVERRUN CLUTCH FEED
- 37 OVERRUN CLUTCH
- 38 D2
- 39 ORIFICED D2
- 40 3-2 SIGNAL
- 41 LO
- 42 LO/1ST
- 43 EXHAUST
- 44 ORIFICED EXHAUST
- 45 VENT
- 46 SEAL DRAIN
- 47 VOID
- 48 REGULATED APPLY

COMPONENTS ()

- (8) REAR LUBE (ORIFICED CUP PLUG/REAR CASE)
- (10) OIL COOLER PIPE CONNECTOR
- (11) CASE SERVO ORIFICED PLUG
- (38) ACCUMULATOR BLEED PLUG
- (39) LINE PRESSURE TAP
- (40) 3RD ACCUM. RETAINER AND BALL ASSEMBLY (#7)
- (49) SHIFT SOLENOIDS SCREEN
- (50) PRESSURE CONTROL SOLENOID SCREEN
- (61) CHECKBALLS (#1, 2, 3, 4, 5, 6, 8, 12)
- (91) CHECKBALL (#10)
- (232) OIL PUMP COVER SCREEN
- (237) CHECK VALVE RETAINER AND BALL ASSEMBLY
- (238) CONVERTER CLUTCH SIGNAL ORIFICED CUP PLUG
- (240) ORIFICED CUP PLUG

OVERDRIVE RANGE - SECOND GEAR

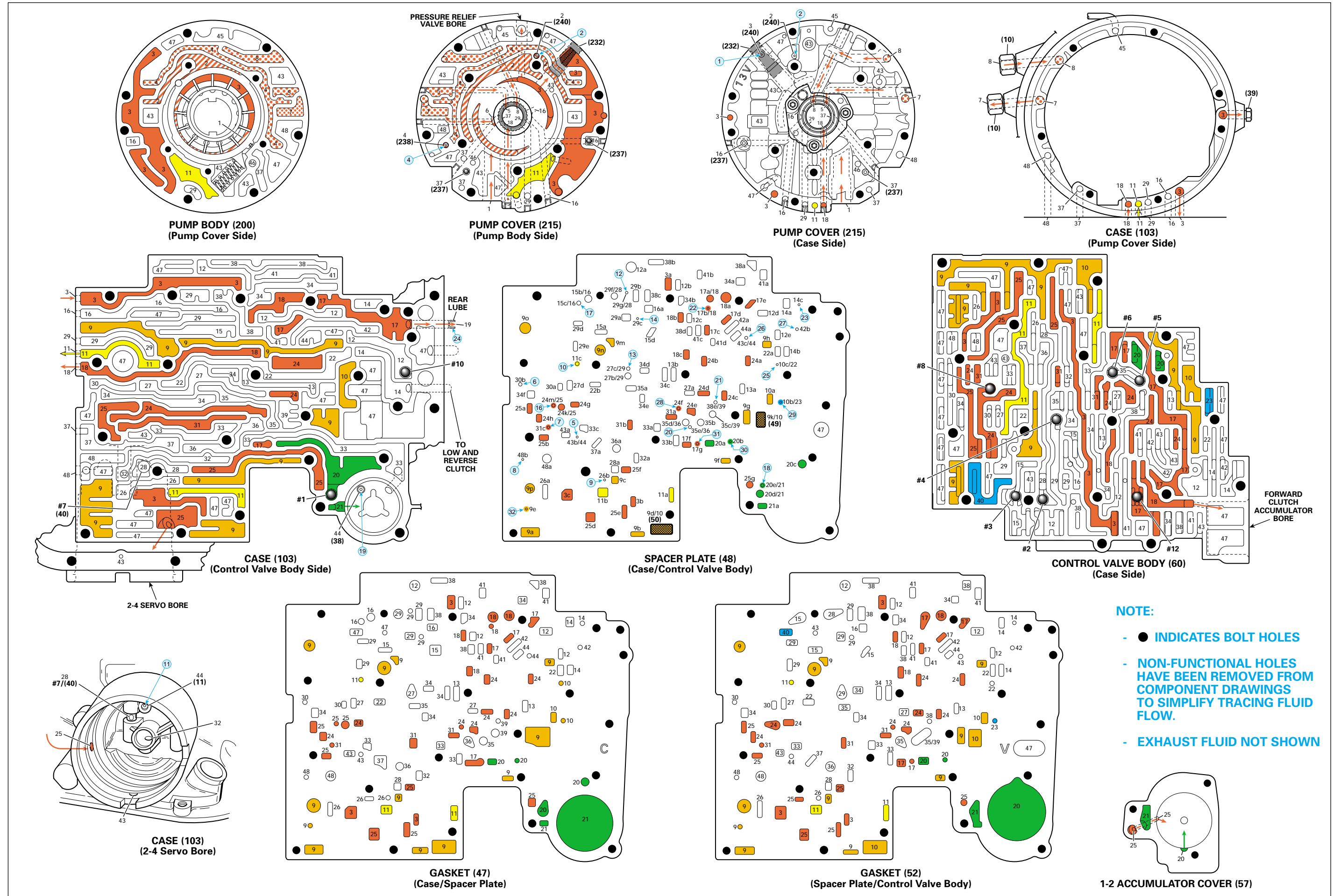
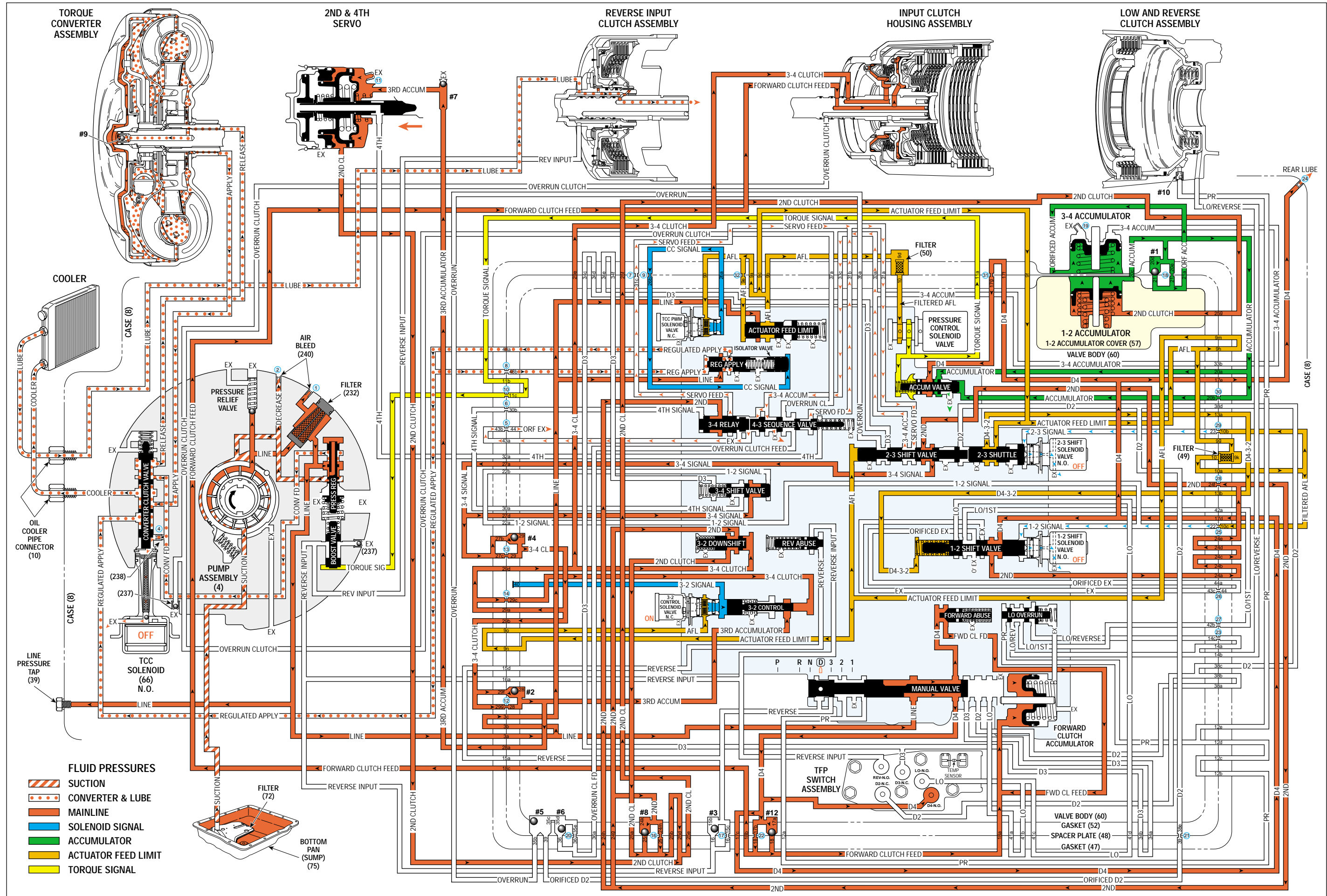

Figure 80

OVERDRIVE RANGE - THIRD GEAR



OVERDRIVE RANGE – THIRD GEAR

NO 2-3 SHIFT OR 2-3 SHIFT SLIPS, ROUGH OR HUNTING

- 1-2 Accumulator Valve (371)
 - Stuck
- 2-4 Servo Assembly
 - Restricted or missing oil passages
 - Servo bore in case damaged
- 2-4 Band (602)
 - Worn or mispositioned

THIRD GEAR ONLY

- System Voltage
 - 12 volts not supplied to transmission
 - Electrical short (pinched solenoid wire)
- 3-2 Control Solenoid (394)
 - Shorted or damaged
 - Contamination
 - Damaged Seal

1-2 SHIFT SOLENOID VALVE	2-3 SHIFT SOLENOID VALVE	2-4 BAND	REVERSE INPUT CLUTCH	OVERRUN CLUTCH	FORWARD CLUTCH	FORWARD SPRAG CL. ASSEMBLY	3-4 CLUTCH	LO-ROLLER CLUTCH	LO/REV CLUTCH
OFF	OFF				APPLIED	HOLDING	APPLIED		

OVERDRIVE RANGE – THIRD GEAR

PASSAGES

- 1 SUCTION
- 2 DECREASE
- 3 LINE
- 4 CONVERTER FEED
- 5 RELEASE
- 6 APPLY
- 7 COOLER
- 8 LUBE
- 9 ACTUATOR FEED LIMIT
- 10 FILTERED ACTUATOR FEED
- 11 TORQUE SIGNAL
- 12 PR
- 13 D4-3-2
- 14 LO/REVERSE
- 15 REVERSE
- 16 REVERSE INPUT
- 17 D4
- 18 FORWARD CLUTCH FEED
- 19 REAR LUBE
- 20 ACCUMULATOR
- 21 ORIFICED ACCUMULATOR
- 22 1-2 SIGNAL
- 23 2-3 SIGNAL
- 24 2ND
- 25 2ND CLUTCH
- 26 C. C. SIGNAL
- 27 3-4 SIGNAL
- 28 3RD ACCUMULATOR
- 29 3-4 CLUTCH
- 30 4TH SIGNAL
- 31 SERVO FEED
- 32 4TH
- 33 3-4 ACCUMULATOR
- 34 D3
- 35 OVERRUN
- 36 OVERRUN CLUTCH FEED
- 37 OVERRUN CLUTCH
- 38 D2
- 39 ORIFICED D2
- 40 3-2 SIGNAL
- 41 LO
- 42 LO/1ST
- 43 EXHAUST
- 44 ORIFICED EXHAUST
- 45 VENT
- 46 SEAL DRAIN
- 47 VOID
- 48 REGULATED APPLY

COMPONENTS ()

- (8) REAR LUBE (ORIFICED CUP PLUG/REAR CASE)
- (10) OIL COOLER PIPE CONNECTOR
- (11) CASE SERVO ORIFICED PLUG
- (38) ACCUMULATOR BLEED PLUG
- (39) LINE PRESSURE TAP
- (40) 3RD ACCUM. RETAINER AND BALL ASSEMBLY (#7)
- (49) SHIFT SOLENOIDS SCREEN
- (50) PRESSURE CONTROL SOLENOID SCREEN
- (61) CHECKBALLS (#1, 2, 3, 4, 5, 6, 8, 12)
- (91) CHECKBALL (#10)
- (232) OIL PUMP COVER SCREEN
- (237) CHECK VALVE RETAINER AND BALL ASSEMBLY
- (238) CONVERTER CLUTCH SIGNAL ORIFICED CUP PLUG
- (240) ORIFICED CUP PLUG

OVERDRIVE RANGE - THIRD GEAR

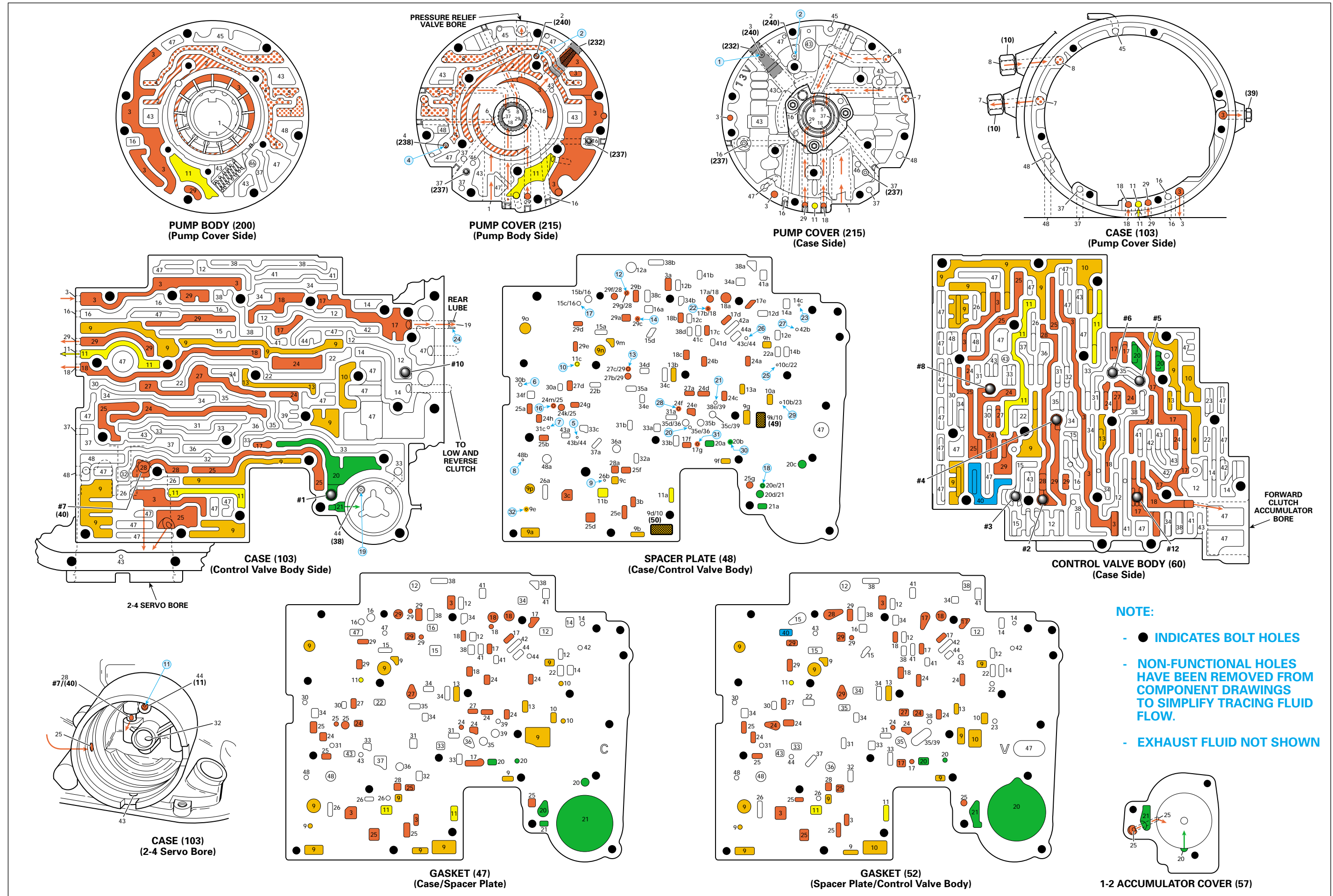

Figure 82

OVERDRIVE RANGE – FOURTH GEAR (Torque Converter Clutch Applied)

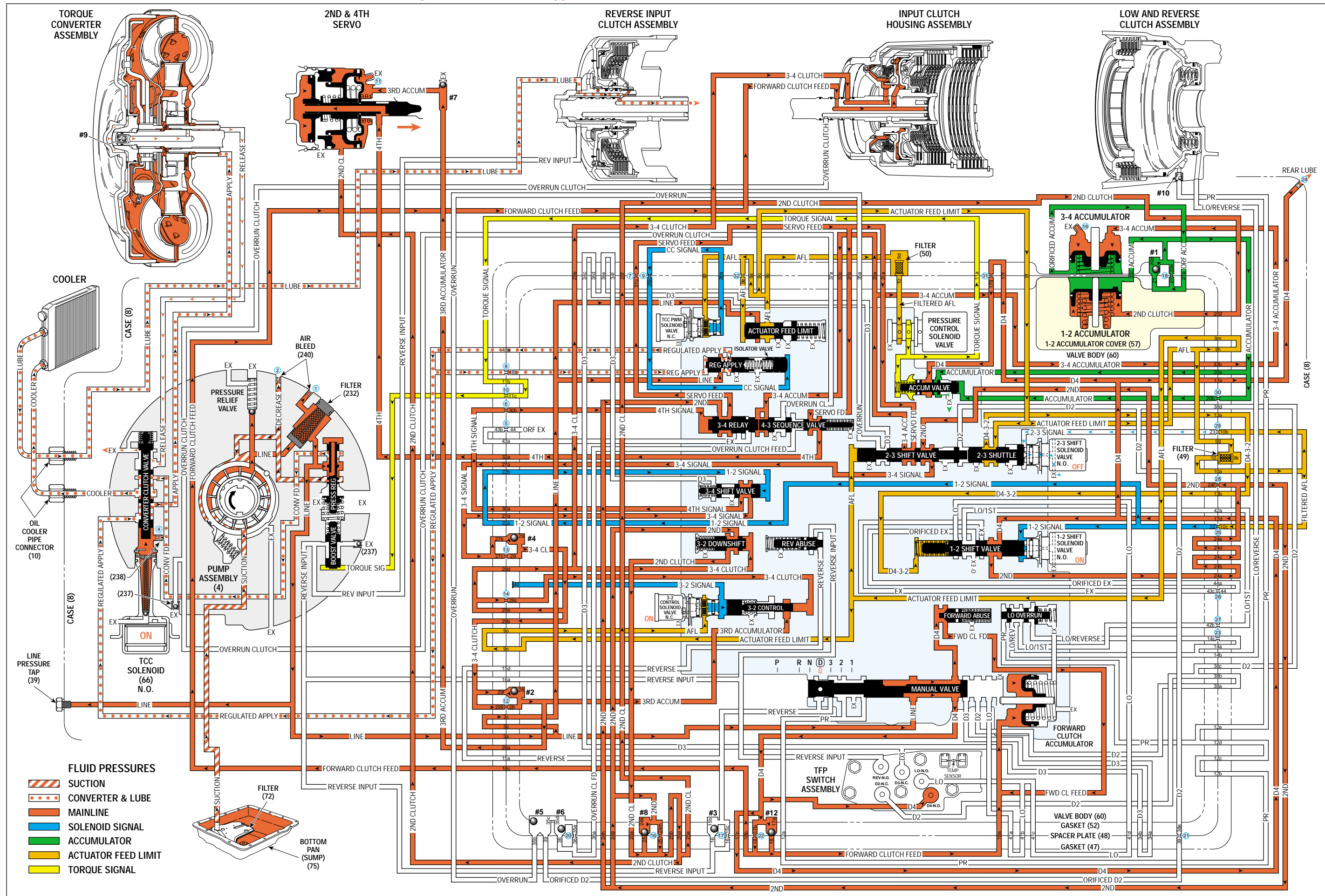

Figure 83

OVERDRIVE RANGE – FOURTH GEAR

(Torque Converter Clutch Applied)

NO TCC APPLY

- Torque Converter (1)
 - Internal damage
- Converter Clutch Valve (224)
 - Stuck or assembled backwards
- Orifice Cup Plug (240)
 - Restricted or damaged
- Turbine Shaft O-ring Seal (618)
 - Cut or damaged

NO 3-4 SHIFT, SLIPS OR ROUGH 3-4 SHIFT

- 2-4 Servo Assembly
 - Incorrect band apply pin
 - Porosity in piston, cover or case
 - Plugged or missing orifice cup plug

1-2 SHIFT SOLENOID VALVE	2-3 SHIFT SOLENOID VALVE	2-4 BAND	REVERSE INPUT CLUTCH	OVERRUN CLUTCH	FORWARD CLUTCH	FORWARD SPRAG CL. ASSEMBLY	3-4 CLUTCH	LO-ROLLER CLUTCH	LO/REV CLUTCH
ON	OFF	APPLIED			APPLIED		APPLIED		

OVERDRIVE RANGE – FOURTH GEAR

(Torque Converter Clutch Applied)

PASSAGES

- 1 SUCTION
- 2 DECREASE
- 3 LINE
- 4 CONVERTER FEED
- 5 RELEASE
- 6 APPLY
- 7 COOLER
- 8 LUBE
- 9 ACTUATOR FEED LIMIT
- 10 FILTERED ACTUATOR FEED
- 11 TORQUE SIGNAL
- 12 PR
- 13 D4-3-2
- 14 LO/REVERSE
- 15 REVERSE
- 16 REVERSE INPUT
- 17 D4
- 18 FORWARD CLUTCH FEED
- 19 REAR LUBE
- 20 ACCUMULATOR
- 21 ORIFICED ACCUMULATOR
- 22 1-2 SIGNAL
- 23 2-3 SIGNAL
- 24 2ND
- 25 2ND CLUTCH
- 26 C. C. SIGNAL
- 27 3-4 SIGNAL
- 28 3RD ACCUMULATOR
- 29 3-4 CLUTCH
- 30 4TH SIGNAL
- 31 SERVO FEED
- 32 4TH
- 33 3-4 ACCUMULATOR
- 34 D3
- 35 OVERRUN
- 36 OVERRUN CLUTCH FEED
- 37 OVERRUN CLUTCH
- 38 D2
- 39 ORIFICED D2
- 40 3-2 SIGNAL
- 41 LO
- 42 LO/1ST
- 43 EXHAUST
- 44 ORIFICED EXHAUST
- 45 VENT
- 46 SEAL DRAIN
- 47 VOID
- 48 REGULATED APPLY

COMPONENTS ()

- (8) REAR LUBE (ORIFICED CUP PLUG/REAR CASE)
- (10) OIL COOLER PIPE CONNECTOR
- (11) CASE SERVO ORIFICED PLUG
- (38) ACCUMULATOR BLEED PLUG
- (39) LINE PRESSURE TAP
- (40) 3RD ACCUM. RETAINER AND BALL ASSEMBLY (#7)
- (49) SHIFT SOLENOIDS SCREEN
- (50) PRESSURE CONTROL SOLENOID SCREEN
- (61) CHECKBALLS (#1, 2, 3, 4, 5, 6, 8, 12)
- (91) CHECKBALL (#10)
- (232) OIL PUMP COVER SCREEN
- (237) CHECK VALVE RETAINER AND BALL ASSEMBLY
- (238) CONVERTER CLUTCH SIGNAL ORIFICED CUP PLUG
- (240) ORIFICED CUP PLUG

OVERDRIVE RANGE – FOURTH GEAR (Torque Converter Clutch Applied)

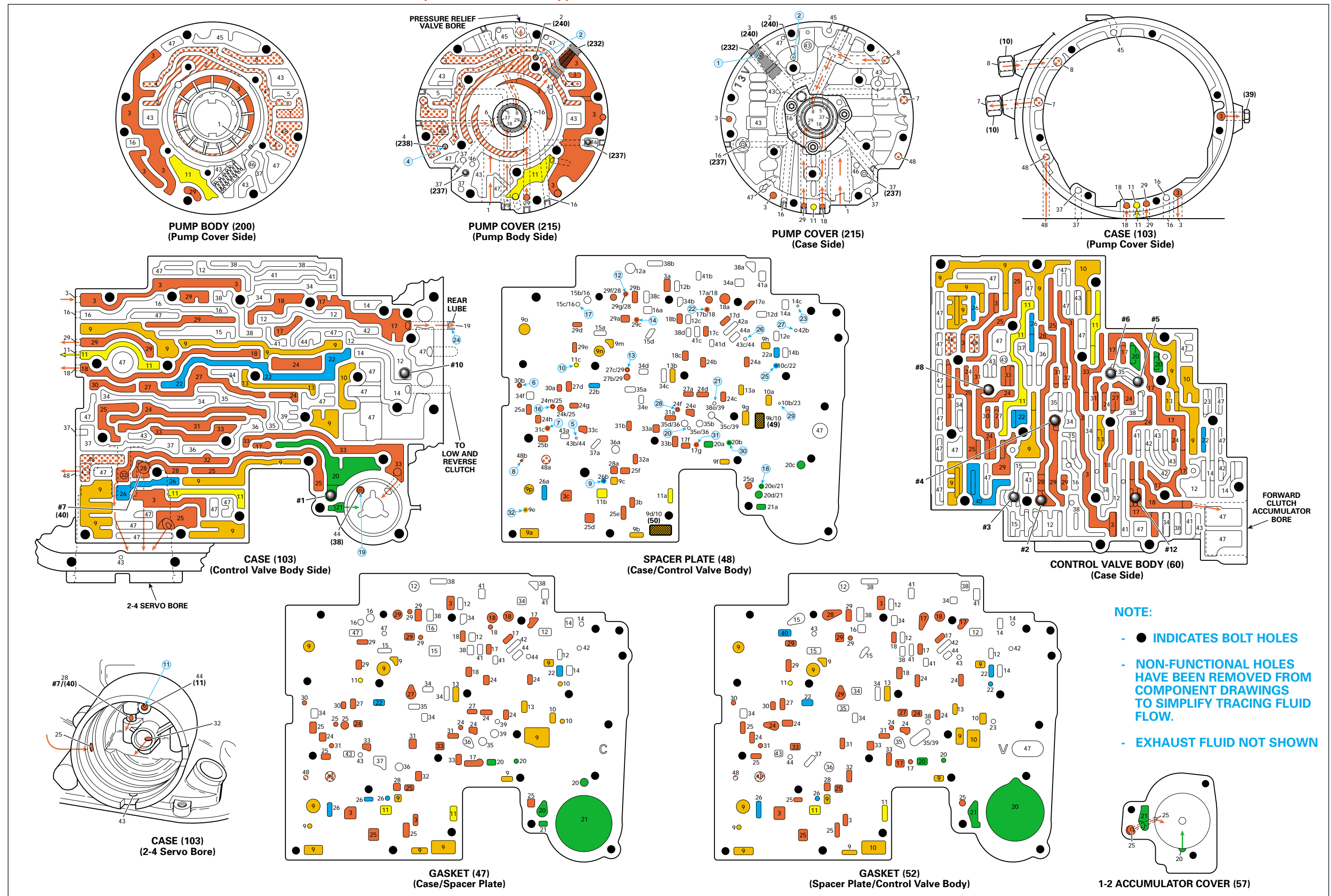

Figure 84

OVERDRIVE RANGE – 4-3 DOWNSHIFT (Torque Converter Clutch Released)

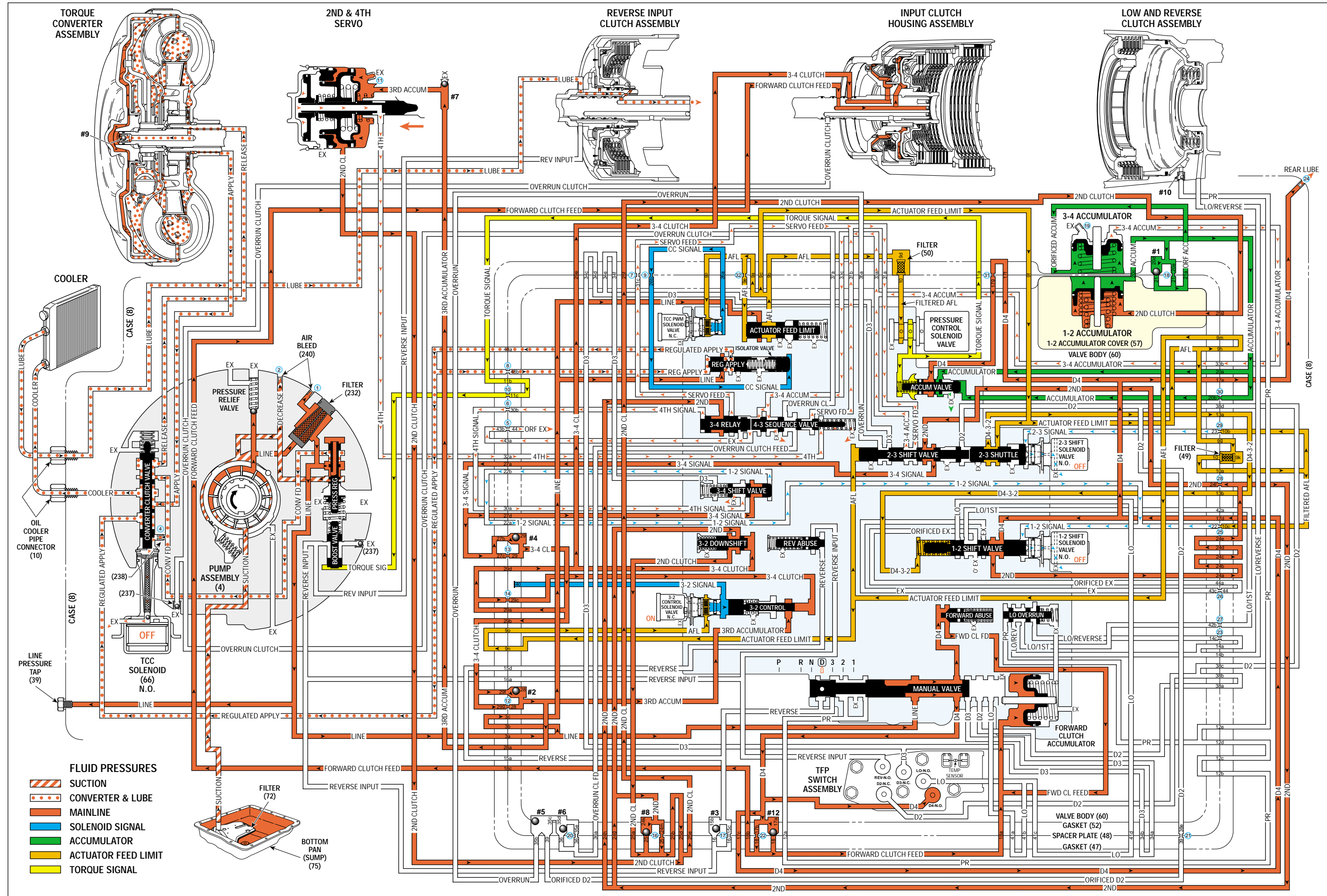

Figure 85

OVERDRIVE RANGE – 4-3 DOWNSHIFT (Torque Converter Clutch Released)

With the transmission operating in Fourth gear, a 4-3 downshift can occur due to minimum or heavy throttle conditions or increased load on the engine. The TCC and 4th clutch release during a 4-3 downshift and the TCC normally will not apply in Overdrive range Third gear.

NO 4-3 DOWNSHIFT

- 1-2 Shift Solenoid Valve (367A)
 - Stuck On
 - Pinched wire to ground
- 3-4 Shift Valve (385)
 - Stuck in upshift position
- 4-3 Sequence Valve (383)
 - Stuck

TCC STUCK ON

- TCC PWM Solenoid Valve (396)
 - Stuck On
 - Pinched wire to ground
- Regulated Apply Valve (380)
 - Stuck

1-2 SHIFT SOLENOID VALVE	2-3 SHIFT SOLENOID VALVE	2-4 BAND	REVERSE INPUT CLUTCH	OVERRUN CLUTCH	FORWARD CLUTCH	FORWARD SPRAG CL ASSEMBLY	3-4 CLUTCH	LO-ROLLER CLUTCH	LO/REV CLUTCH
OFF	OFF				APPLIED	HOLDING	APPLIED		

OVERDRIVE RANGE – 4-3 DOWNSHIFT (Torque Converter Clutch Released)

PASSAGES

- 1 SUCTION
- 2 DECREASE
- 3 LINE
- 4 CONVERTER FEED
- 5 RELEASE
- 6 APPLY
- 7 COOLER
- 8 LUBE
- 9 ACTUATOR FEED LIMIT
- 10 FILTERED ACTUATOR FEED
- 11 TORQUE SIGNAL
- 12 PR
- 13 D4-3-2
- 14 LO/REVERSE
- 15 REVERSE
- 16 REVERSE INPUT
- 17 D4
- 18 FORWARD CLUTCH FEED
- 19 REAR LUBE
- 20 ACCUMULATOR
- 21 ORIFICED ACCUMULATOR
- 22 1-2 SIGNAL
- 23 2-3 SIGNAL
- 24 2ND
- 25 2ND CLUTCH
- 26 C. C. SIGNAL
- 27 3-4 SIGNAL
- 28 3RD ACCUMULATOR
- 29 3-4 CLUTCH
- 30 4TH SIGNAL
- 31 SERVO FEED
- 32 4TH
- 33 3-4 ACCUMULATOR
- 34 D3
- 35 OVERRUN
- 36 OVERRUN CLUTCH FEED
- 37 OVERRUN CLUTCH
- 38 D2
- 39 ORIFICED D2
- 40 3-2 SIGNAL
- 41 LO
- 42 LO/1ST
- 43 EXHAUST
- 44 ORIFICED EXHAUST
- 45 VENT
- 46 SEAL DRAIN
- 47 VOID
- 48 REGULATED APPLY

COMPONENTS ()

- (8) REAR LUBE (ORIFICED CUP PLUG/REAR CASE)
- (10) OIL COOLER PIPE CONNECTOR
- (11) CASE SERVO ORIFICED PLUG
- (38) ACCUMULATOR BLEED PLUG
- (39) LINE PRESSURE TAP
- (40) 3RD ACCUM. RETAINER AND BALL ASSEMBLY (#7)
- (49) SHIFT SOLENOIDS SCREEN
- (50) PRESSURE CONTROL SOLENOID SCREEN
- (61) CHECKBALLS (#1, 2, 3, 4, 5, 6, 8, 12)
- (91) CHECKBALL (#10)
- (232) OIL PUMP COVER SCREEN
- (237) CHECK VALVE RETAINER AND BALL ASSEMBLY
- (238) CONVERTER CLUTCH SIGNAL ORIFICED CUP PLUG
- (240) ORIFICED CUP PLUG

OVERDRIVE RANGE – 4-3 DOWNSHIFT (Torque Converter Clutch Released)

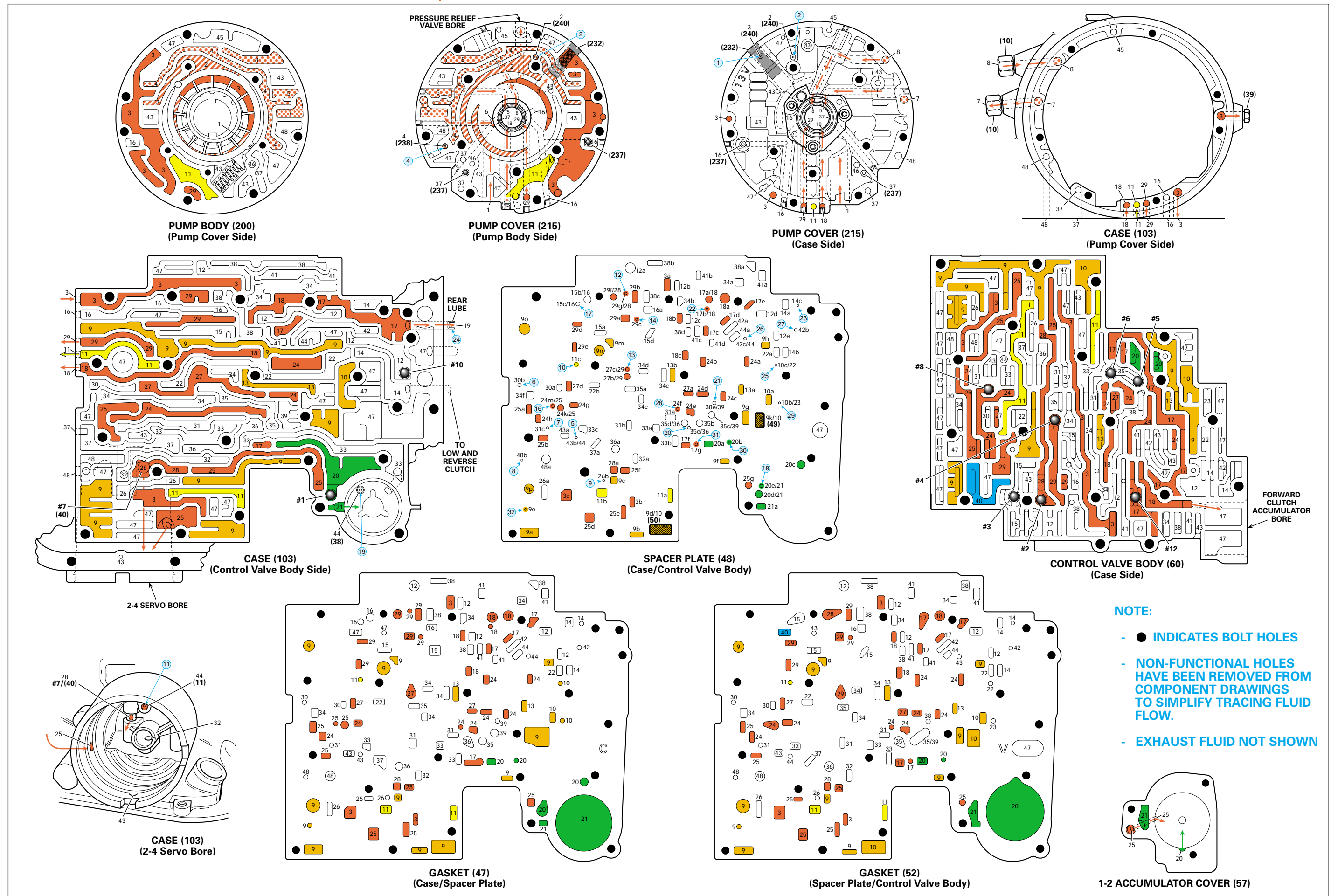

Figure 86

OVERDRIVE RANGE - 3-2 DOWNSHIFT

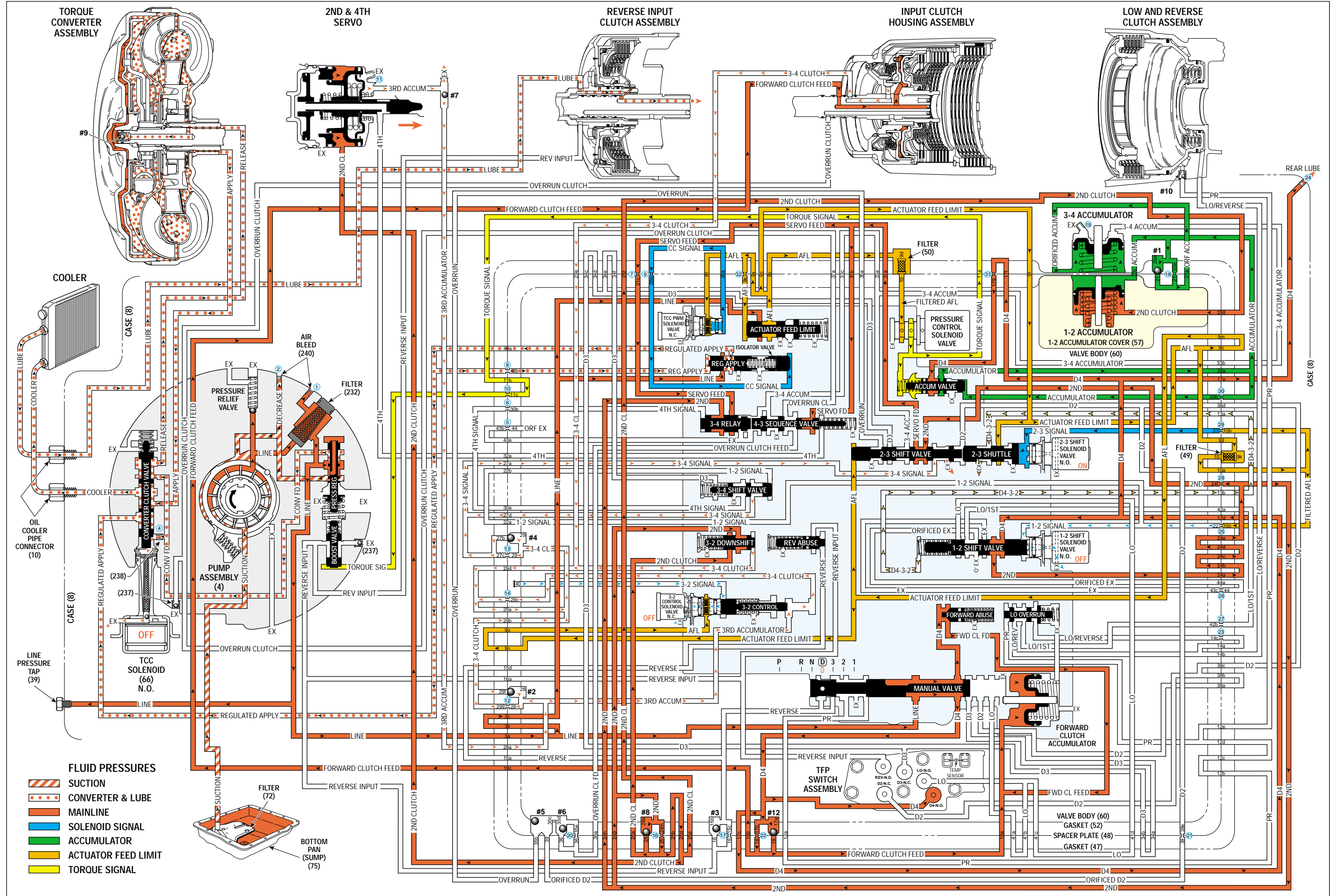

Figure 87

OVERDRIVE RANGE – 3-2 DOWNSHIFT

With the transmission operating in Third gear, a 3-2 downshift can occur due to minimum or heavy throttle conditions or increased load on the engine. A 3-2 downshift occurs when the powertrain control module (PCM) receives the appropriate input signals to de-energize (turn OFF) the 2-3 shift solenoid valve.

3-2 FLARE OR TIE-UP

- 3-2 Control Solenoid (394)
 - Shorted or damaged
 - Contamination
 - Damaged seal

1-2 SHIFT SOLENOID VALVE	2-3 SHIFT SOLENOID VALVE	2-4 BAND	REVERSE INPUT CLUTCH	OVERRUN CLUTCH	FORWARD CLUTCH	FORWARD SPRAG CL. ASSEMBLY	3-4 CLUTCH	LO-ROLLER CLUTCH	LO/REV CLUTCH
OFF	ON	APPLIED			APPLIED	HOLDING			

OVERDRIVE RANGE – 3-2 DOWNSHIFT

PASSAGES

- 1 SUCTION
- 2 DECREASE
- 3 LINE
- 4 CONVERTER FEED
- 5 RELEASE
- 6 APPLY
- 7 COOLER
- 8 LUBE
- 9 ACTUATOR FEED LIMIT
- 10 FILTERED ACTUATOR FEED
- 11 TORQUE SIGNAL
- 12 PR
- 13 D4-3-2
- 14 LO/REVERSE
- 15 REVERSE
- 16 REVERSE INPUT
- 17 D4
- 18 FORWARD CLUTCH FEED
- 19 REAR LUBE
- 20 ACCUMULATOR
- 21 ORIFICED ACCUMULATOR
- 22 1-2 SIGNAL
- 23 2-3 SIGNAL
- 24 2ND
- 25 2ND CLUTCH
- 26 C. C. SIGNAL
- 27 3-4 SIGNAL
- 28 3RD ACCUMULATOR
- 29 3-4 CLUTCH
- 30 4TH SIGNAL
- 31 SERVO FEED
- 32 4TH
- 33 3-4 ACCUMULATOR
- 34 D3
- 35 OVERRUN
- 36 OVERRUN CLUTCH FEED
- 37 OVERRUN CLUTCH
- 38 D2
- 39 ORIFICED D2
- 40 3-2 SIGNAL
- 41 LO
- 42 LO/1ST
- 43 EXHAUST
- 44 ORIFICED EXHAUST
- 45 VENT
- 46 SEAL DRAIN
- 47 VOID
- 48 REGULATED APPLY

COMPONENTS ()

- (8) REAR LUBE (ORIFICED CUP PLUG/REAR CASE)
- (10) OIL COOLER PIPE CONNECTOR
- (11) CASE SERVO ORIFICED PLUG
- (38) ACCUMULATOR BLEED PLUG
- (39) LINE PRESSURE TAP
- (40) 3RD ACCUM. RETAINER AND BALL ASSEMBLY (#7)
- (49) SHIFT SOLENOIDS SCREEN
- (50) PRESSURE CONTROL SOLENOID SCREEN
- (61) CHECKBALLS (#1, 2, 3, 4, 5, 6, 8, 12)
- (91) CHECKBALL (#10)
- (232) OIL PUMP COVER SCREEN
- (237) CHECK VALVE RETAINER AND BALL ASSEMBLY
- (238) CONVERTER CLUTCH SIGNAL ORIFICED CUP PLUG
- (240) ORIFICED CUP PLUG

OVERDRIVE RANGE - 3-2 DOWNSHIFT

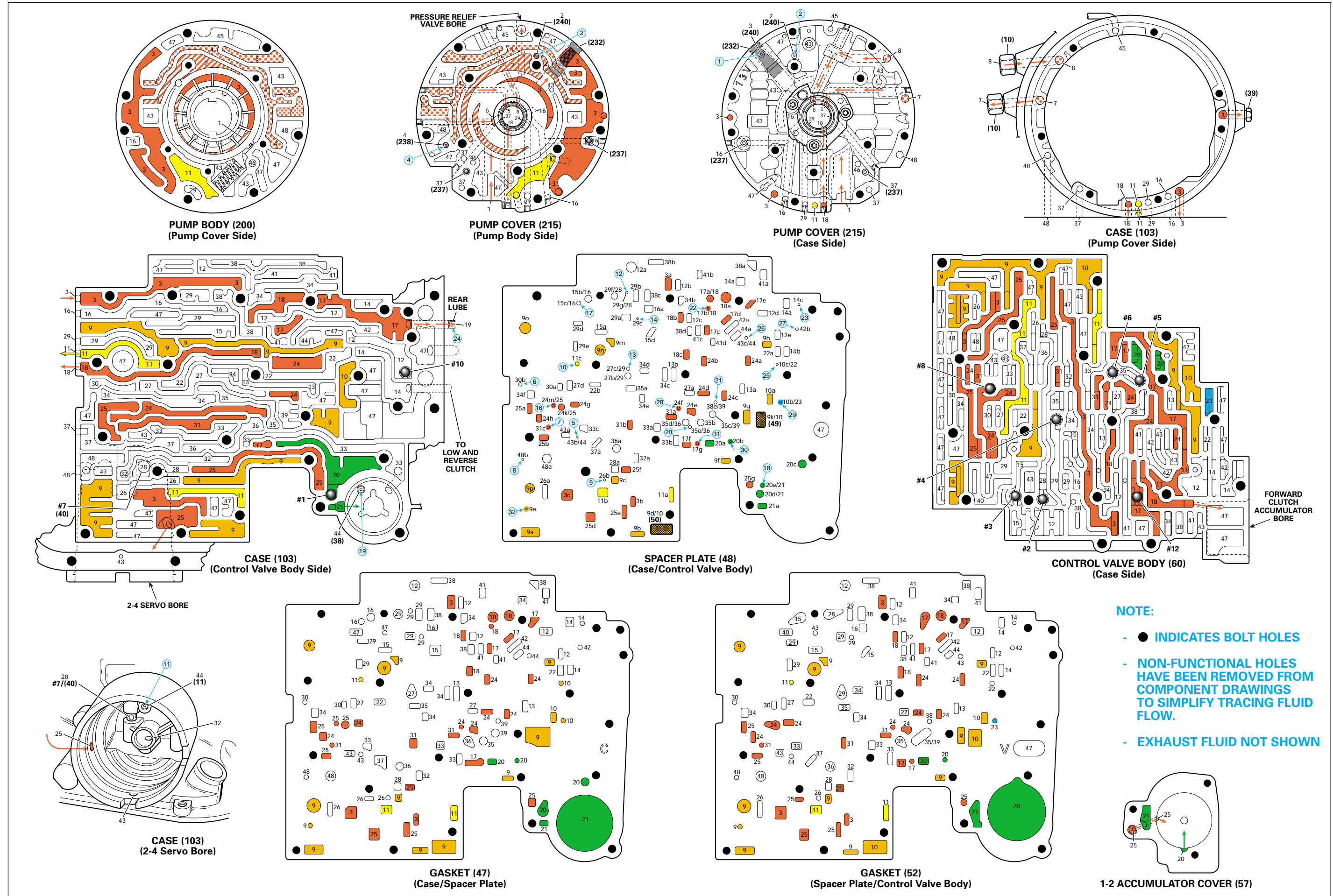

Figure 88

MANUAL THIRD – THIRD GEAR (from Overdrive Range – Fourth Gear)

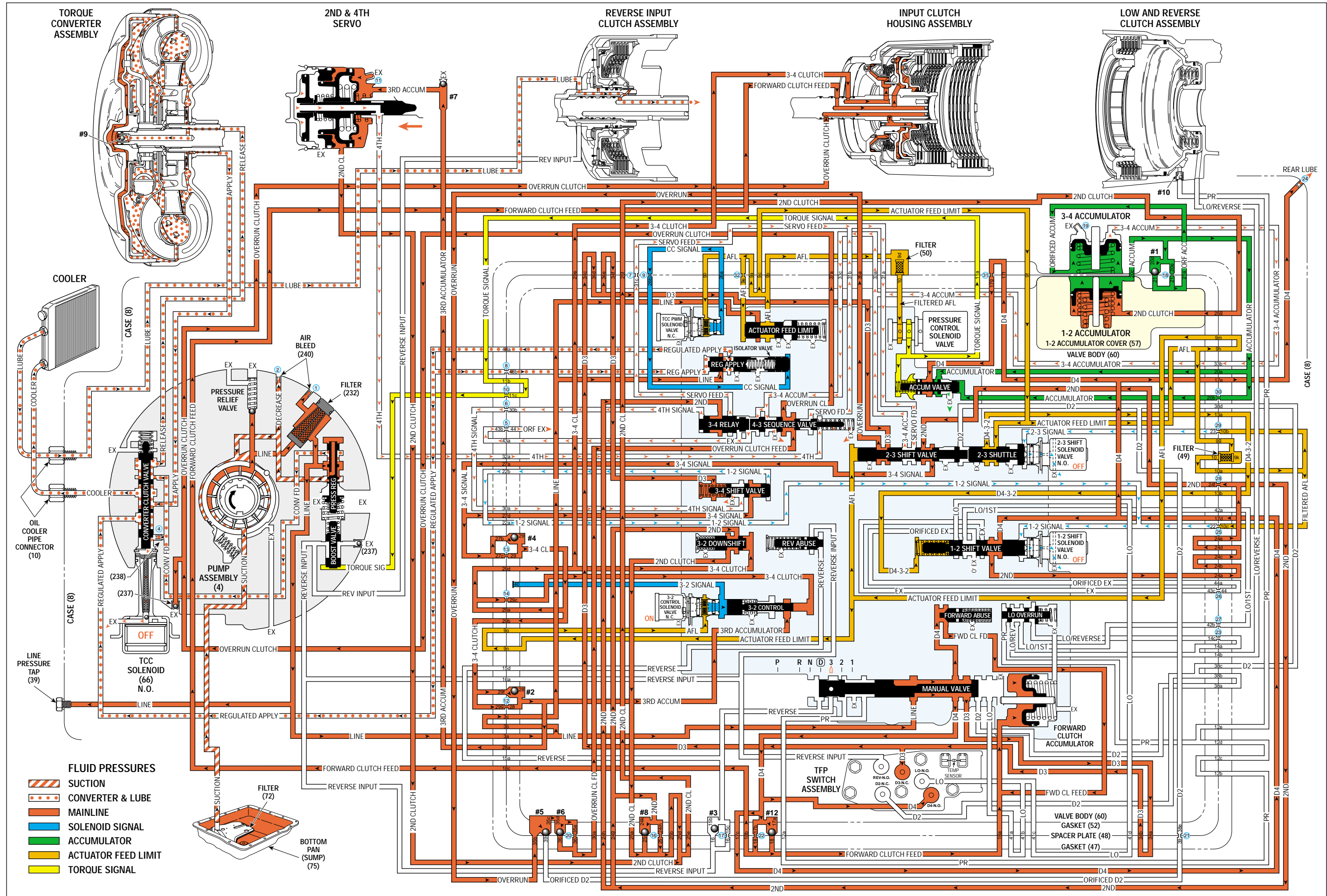

Figure 89

MANUAL THIRD – THIRD GEAR (from Overdrive Range – Fourth Gear)

A manual 4-3 downshift can be accomplished by moving the gear selector lever into the Manual Third position (D) when the transmission is operating in Overdrive Range - Fourth Gear D .

NO OVERRUN BRAKING-MANUAL 3-2-1

- External Linkage
 - Not adjusted properly
- Input Clutch Assembly
 - Turbine shaft oil passages plugged or not drilled
 - Turbine shaft sealing balls loose or missing
 - Overrun piston checkball not sealing
- Valve Body Assembly
 - Checkball mispositioned
 - 4-3 sequence valve stuck

1-2 SHIFT SOLENOID VALVE	2-3 SHIFT SOLENOID VALVE	2-4 BAND	REVERSE INPUT CLUTCH	OVERRUN CLUTCH	FORWARD CLUTCH	FORWARD SPRAG CL. ASSEMBLY	3-4 CLUTCH	LO-ROLLER CLUTCH	LO/REV CLUTCH
OFF	OFF			APPLIED	APPLIED	HOLDING	APPLIED		

MANUAL THIRD – THIRD GEAR

(from Overdrive Range – Fourth Gear)

PASSAGES

- 1 SUCTION
- 2 DECREASE
- 3 LINE
- 4 CONVERTER FEED
- 5 RELEASE
- 6 APPLY
- 7 COOLER
- 8 LUBE
- 9 ACTUATOR FEED LIMIT
- 10 FILTERED ACTUATOR FEED
- 11 TORQUE SIGNAL
- 12 PR
- 13 D4-3-2
- 14 LO/REVERSE
- 15 REVERSE
- 16 REVERSE INPUT
- 17 D4
- 18 FORWARD CLUTCH FEED
- 19 REAR LUBE
- 20 ACCUMULATOR
- 21 ORIFICED ACCUMULATOR
- 22 1-2 SIGNAL
- 23 2-3 SIGNAL
- 24 2ND
- 25 2ND CLUTCH
- 26 C. C. SIGNAL
- 27 3-4 SIGNAL
- 28 3RD ACCUMULATOR
- 29 3-4 CLUTCH
- 30 4TH SIGNAL
- 31 SERVO FEED
- 32 4TH
- 33 3-4 ACCUMULATOR
- 34 D3
- 35 OVERRUN
- 36 OVERRUN CLUTCH FEED
- 37 OVERRUN CLUTCH
- 38 D2
- 39 ORIFICED D2
- 40 3-2 SIGNAL
- 41 LO
- 42 LO/1ST
- 43 EXHAUST
- 44 ORIFICED EXHAUST
- 45 VENT
- 46 SEAL DRAIN
- 47 VOID
- 48 REGULATED APPLY

COMPONENTS ()

- (8) REAR LUBE (ORIFICED CUP PLUG/REAR CASE)
- (10) OIL COOLER PIPE CONNECTOR
- (11) CASE SERVO ORIFICED PLUG
- (38) ACCUMULATOR BLEED PLUG
- (39) LINE PRESSURE TAP
- (40) 3RD ACCUM. RETAINER AND BALL ASSEMBLY (#7)
- (49) SHIFT SOLENOIDS SCREEN
- (50) PRESSURE CONTROL SOLENOID SCREEN
- (61) CHECKBALLS (#1, 2, 3, 4, 5, 6, 8, 12)
- (91) CHECKBALL (#10)
- (232) OIL PUMP COVER SCREEN
- (237) CHECK VALVE RETAINER AND BALL ASSEMBLY
- (238) CONVERTER CLUTCH SIGNAL ORIFICED CUP PLUG
- (240) ORIFICED CUP PLUG

MANUAL THIRD – THIRD GEAR (from Overdrive Range – Fourth Gear)

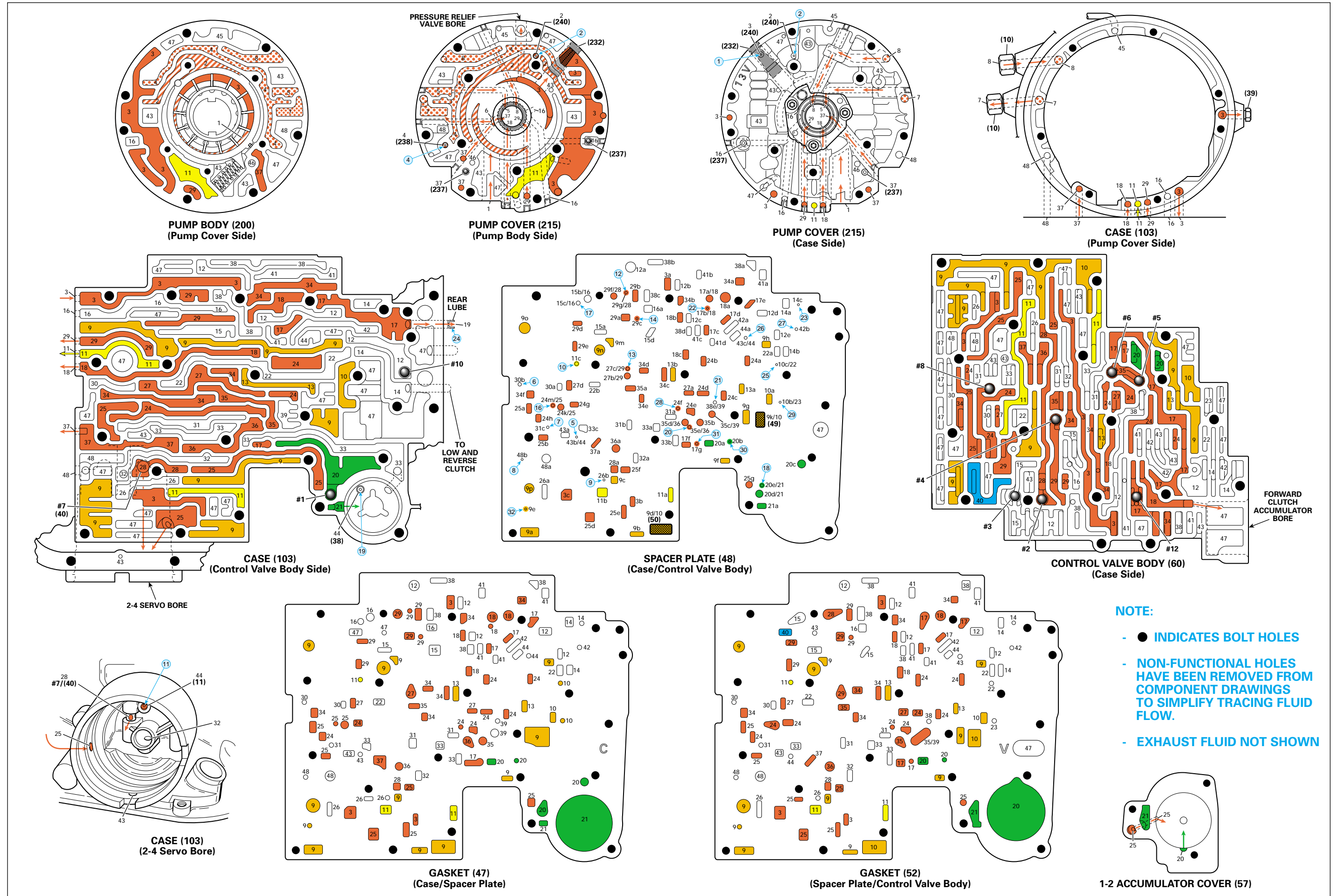

Figure 90

MANUAL SECOND – SECOND GEAR (from Manual Third – Third Gear)

A manual 3-2 downshift can be accomplished by moving the gear selector lever into the Manual Second (2) position when the transmission is operating in Third gear. This causes the transmission to shift immediately into Second gear and prevents the transmission from upshifting to either Third or Fourth gears.

NO OVERRUN BRAKING-MANUAL 3-2-1

- External Linkage
 - Not adjusted properly
- Input Clutch Assembly
 - Turbine shaft oil passages plugged or not drilled
 - Turbine shaft sealing balls loose or missing
 - Overrun piston checkball not sealing
- Valve Body Assembly
 - Checkball mispositioned
 - 4-3 sequence valve stuck

1-2 SHIFT SOLENOID VALVE	2-3 SHIFT SOLENOID VALVE	2-4 BAND	REVERSE INPUT CLUTCH	OVERRUN CLUTCH	FORWARD CLUTCH	FORWARD SPRAG CL. ASSEMBLY	3-4 CLUTCH	LO-ROLLER CLUTCH	LO/REV CLUTCH
OFF	ON	APPLIED		APPLIED	APPLIED	HOLDING			

MANUAL SECOND – SECOND GEAR

(from Manual Third – Third Gear)

PASSAGES

- 1 SUCTION
- 2 DECREASE
- 3 LINE
- 4 CONVERTER FEED
- 5 RELEASE
- 6 APPLY
- 7 COOLER
- 8 LUBE
- 9 ACTUATOR FEED LIMIT
- 10 FILTERED ACTUATOR FEED
- 11 TORQUE SIGNAL
- 12 PR
- 13 D4-3-2
- 14 LO/REVERSE
- 15 REVERSE
- 16 REVERSE INPUT
- 17 D4
- 18 FORWARD CLUTCH FEED
- 19 REAR LUBE
- 20 ACCUMULATOR
- 21 ORIFICED ACCUMULATOR
- 22 1-2 SIGNAL
- 23 2-3 SIGNAL
- 24 2ND
- 25 2ND CLUTCH
- 26 C. C. SIGNAL
- 27 3-4 SIGNAL
- 28 3RD ACCUMULATOR
- 29 3-4 CLUTCH
- 30 4TH SIGNAL
- 31 SERVO FEED
- 32 4TH
- 33 3-4 ACCUMULATOR
- 34 D3
- 35 OVERRUN
- 36 OVERRUN CLUTCH FEED
- 37 OVERRUN CLUTCH
- 38 D2
- 39 ORIFICED D2
- 40 3-2 SIGNAL
- 41 LO
- 42 LO/1ST
- 43 EXHAUST
- 44 ORIFICED EXHAUST
- 45 VENT
- 46 SEAL DRAIN
- 47 VOID
- 48 REGULATED APPLY

COMPONENTS ()

- (8) REAR LUBE (ORIFICED CUP PLUG/REAR CASE)
- (10) OIL COOLER PIPE CONNECTOR
- (11) CASE SERVO ORIFICED PLUG
- (38) ACCUMULATOR BLEED PLUG
- (39) LINE PRESSURE TAP
- (40) 3RD ACCUM. RETAINER AND BALL ASSEMBLY (#7)
- (49) SHIFT SOLENOIDS SCREEN
- (50) PRESSURE CONTROL SOLENOID SCREEN
- (61) CHECKBALLS (#1, 2, 3, 4, 5, 6, 8, 12)
- (91) CHECKBALL (#10)
- (232) OIL PUMP COVER SCREEN
- (237) CHECK VALVE RETAINER AND BALL ASSEMBLY
- (238) CONVERTER CLUTCH SIGNAL ORIFICED CUP PLUG
- (240) ORIFICED CUP PLUG

MANUAL SECOND – SECOND GEAR (from Manual Third – Third Gear)

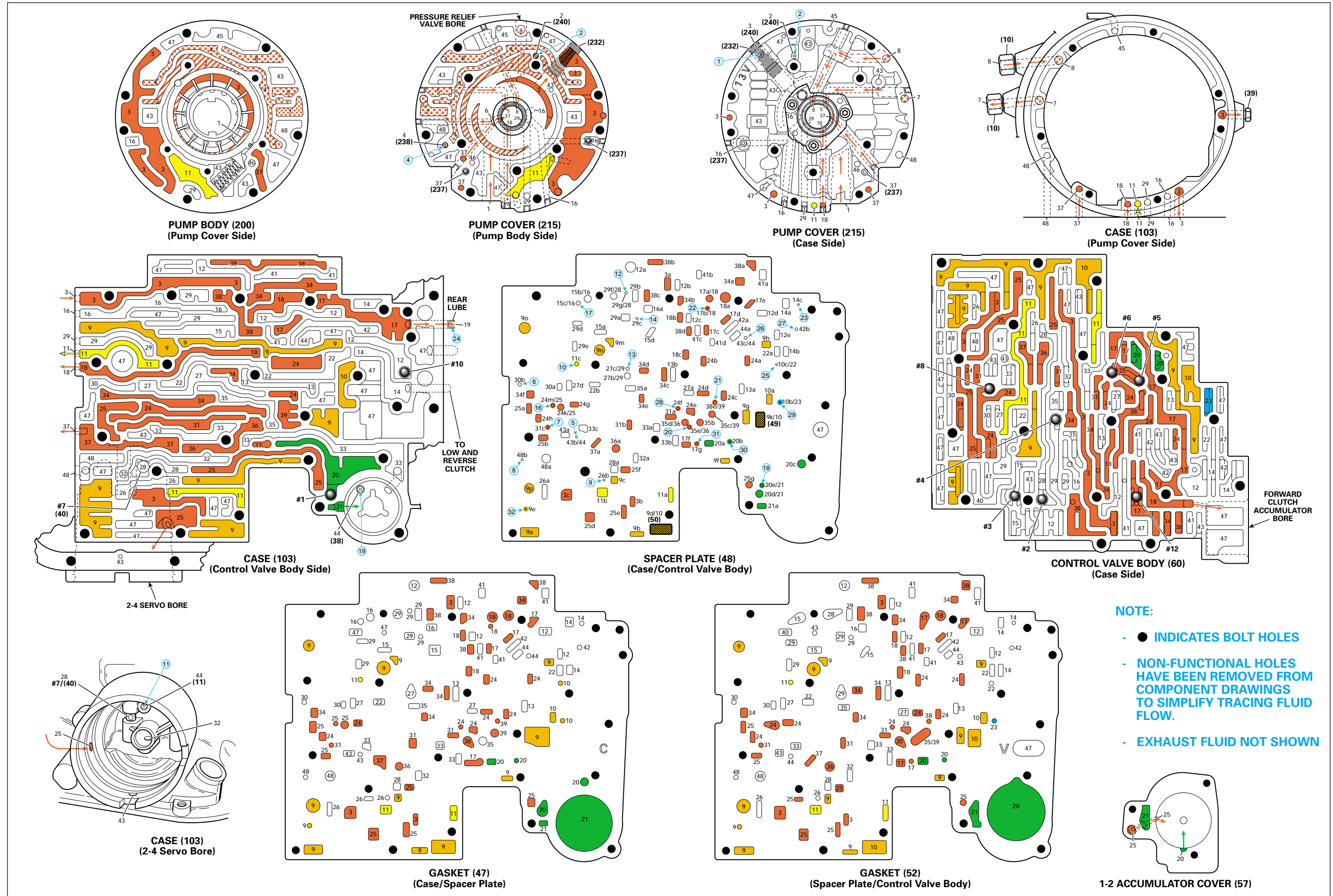

Figure 92

MANUAL FIRST – FIRST GEAR (from Manual Second – Second Gear)

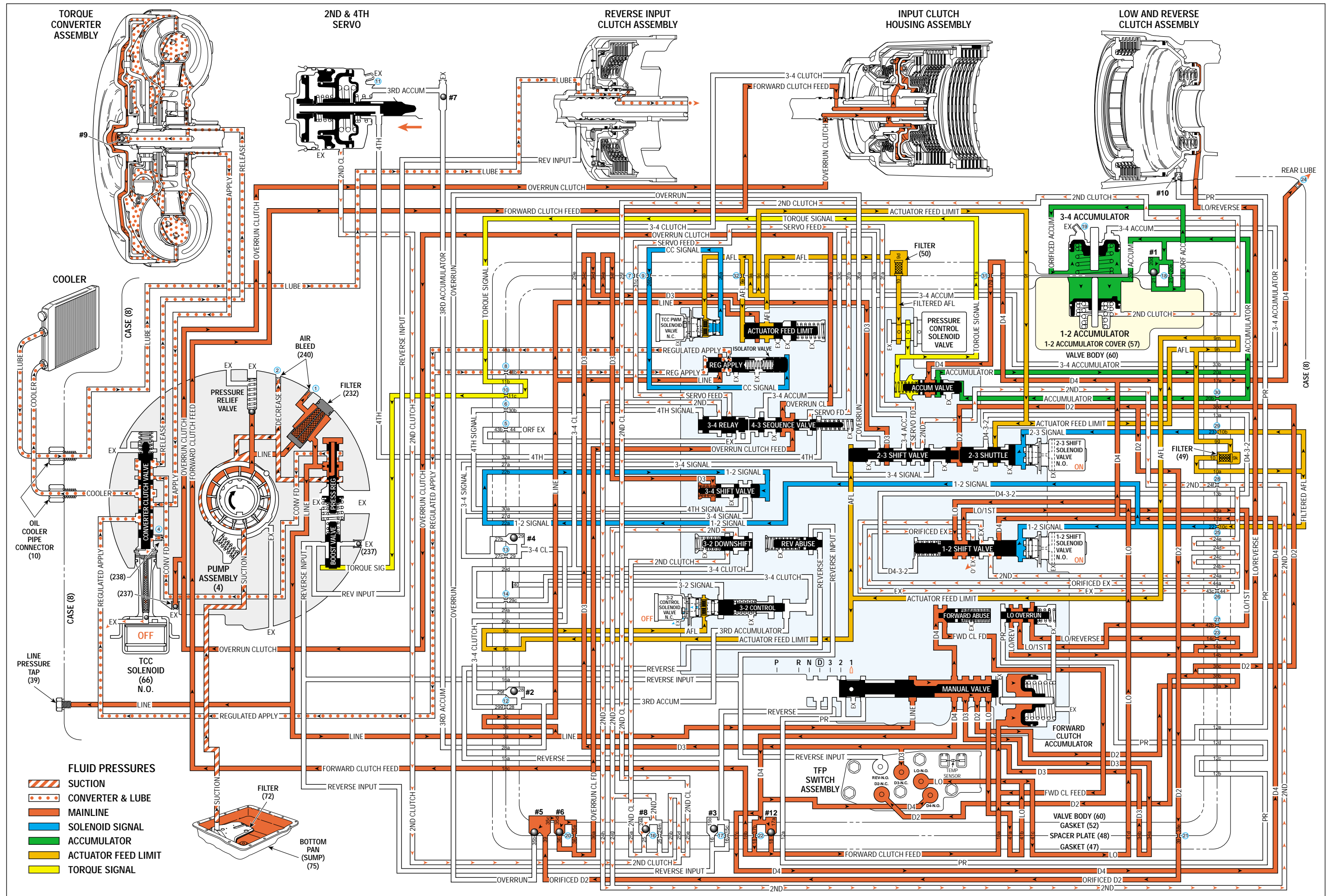

Figure 93

MANUAL FIRST – FIRST GEAR (from Manual Second – Second Gear)

A manual 2-1 downshift can be accomplished by moving the gear selector lever into the Manual First (1) position when the transmission is operating in Second gear. If vehicle speed is below approximately 56 km/h (35 mph) the transmission will shift into First gear. Above this speed, the transmission will shift into a Manual First - Second Gear condition until vehicle speed slows sufficiently.

NO OVERRUN BRAKING-MANUAL 3-2-1

- External Linkage
 - Not adjusted properly
- Input Clutch Assembly
 - Turbine shaft oil passages plugged or not drilled
 - Turbine shaft sealing balls loose or missing
 - Overrun piston checkball not sealing
- Valve Body Assembly
 - Checkball mispositioned
 - 4-3 sequence valve stuck

1-2 SHIFT SOLENOID VALVE	2-3 SHIFT SOLENOID VALVE	2-4 BAND	REVERSE INPUT CLUTCH	OVERRUN CLUTCH	FORWARD CLUTCH	FORWARD SPRAG CL. ASSEMBLY	3-4 CLUTCH	LO-ROLLER CLUTCH	LO/REV CLUTCH
ON	ON			APPLIED	APPLIED	HOLDING		HOLDING	APPLIED

MANUAL FIRST – FIRST GEAR

(from Manual Second – Second Gear)

PASSAGES

- 1 SUCTION
- 2 DECREASE
- 3 LINE
- 4 CONVERTER FEED
- 5 RELEASE
- 6 APPLY
- 7 COOLER
- 8 LUBE
- 9 ACTUATOR FEED LIMIT
- 10 FILTERED ACTUATOR FEED
- 11 TORQUE SIGNAL
- 12 PR
- 13 D4-3-2
- 14 LO/REVERSE
- 15 REVERSE
- 16 REVERSE INPUT
- 17 D4
- 18 FORWARD CLUTCH FEED
- 19 REAR LUBE
- 20 ACCUMULATOR
- 21 ORIFICED ACCUMULATOR
- 22 1-2 SIGNAL
- 23 2-3 SIGNAL
- 24 2ND
- 25 2ND CLUTCH
- 26 C. C. SIGNAL
- 27 3-4 SIGNAL
- 28 3RD ACCUMULATOR
- 29 3-4 CLUTCH
- 30 4TH SIGNAL
- 31 SERVO FEED
- 32 4TH
- 33 3-4 ACCUMULATOR
- 34 D3
- 35 OVERRUN
- 36 OVERRUN CLUTCH FEED
- 37 OVERRUN CLUTCH
- 38 D2
- 39 ORIFICED D2
- 40 3-2 SIGNAL
- 41 LO
- 42 LO/1ST
- 43 EXHAUST
- 44 ORIFICED EXHAUST
- 45 VENT
- 46 SEAL DRAIN
- 47 VOID
- 48 REGULATED APPLY

COMPONENTS ()

- (8) REAR LUBE (ORIFICED CUP PLUG/REAR CASE)
- (10) OIL COOLER PIPE CONNECTOR
- (11) CASE SERVO ORIFICED PLUG
- (38) ACCUMULATOR BLEED PLUG
- (39) LINE PRESSURE TAP
- (40) 3RD ACCUM. RETAINER AND BALL ASSEMBLY (#7)
- (49) SHIFT SOLENOIDS SCREEN
- (50) PRESSURE CONTROL SOLENOID SCREEN
- (61) CHECKBALLS (#1, 2, 3, 4, 5, 6, 8, 12)
- (91) CHECKBALL (#10)
- (232) OIL PUMP COVER SCREEN
- (237) CHECK VALVE RETAINER AND BALL ASSEMBLY
- (238) CONVERTER CLUTCH SIGNAL ORIFICED CUP PLUG
- (240) ORIFICED CUP PLUG

MANUAL FIRST – FIRST GEAR (from Manual Second – Second Gear)

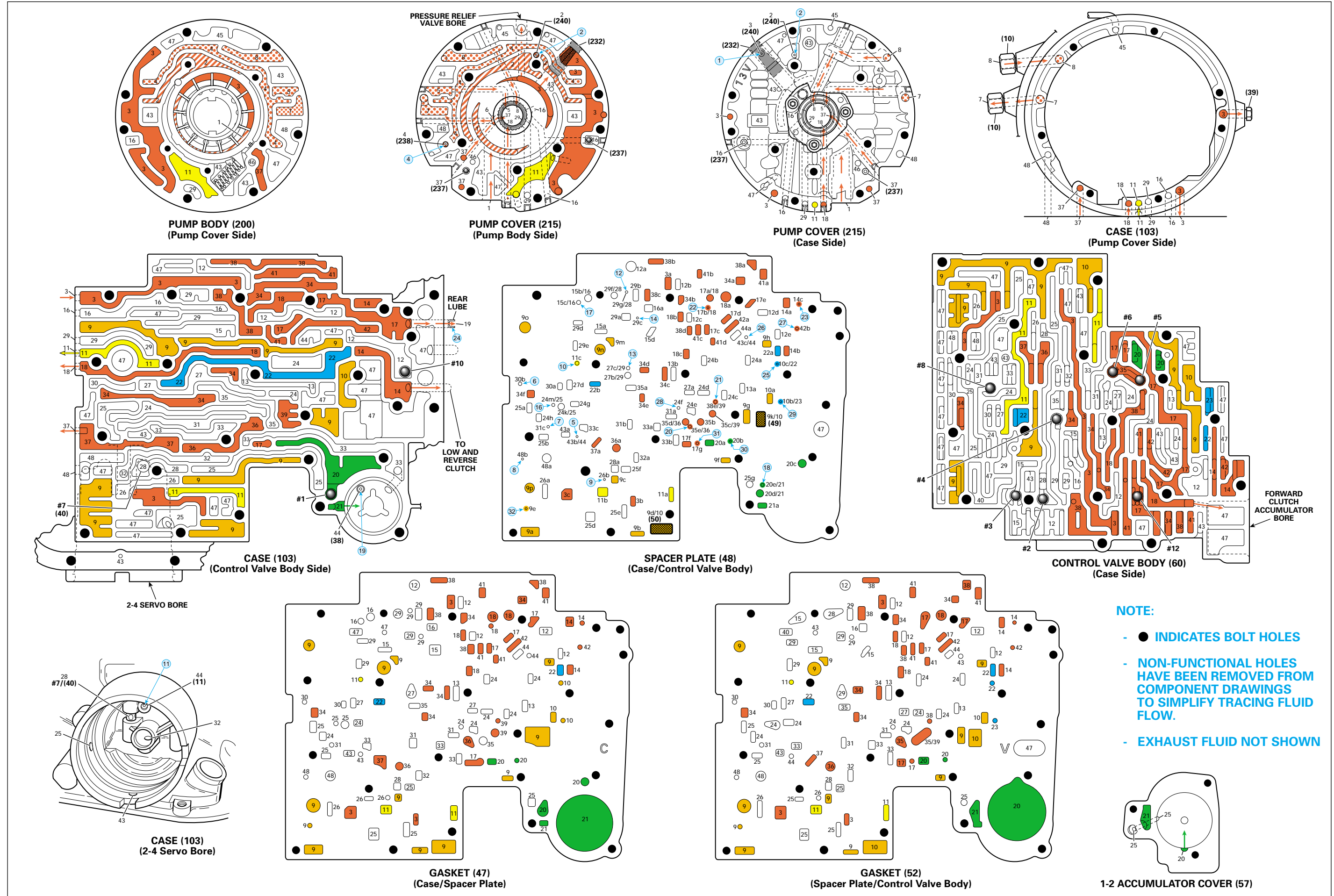
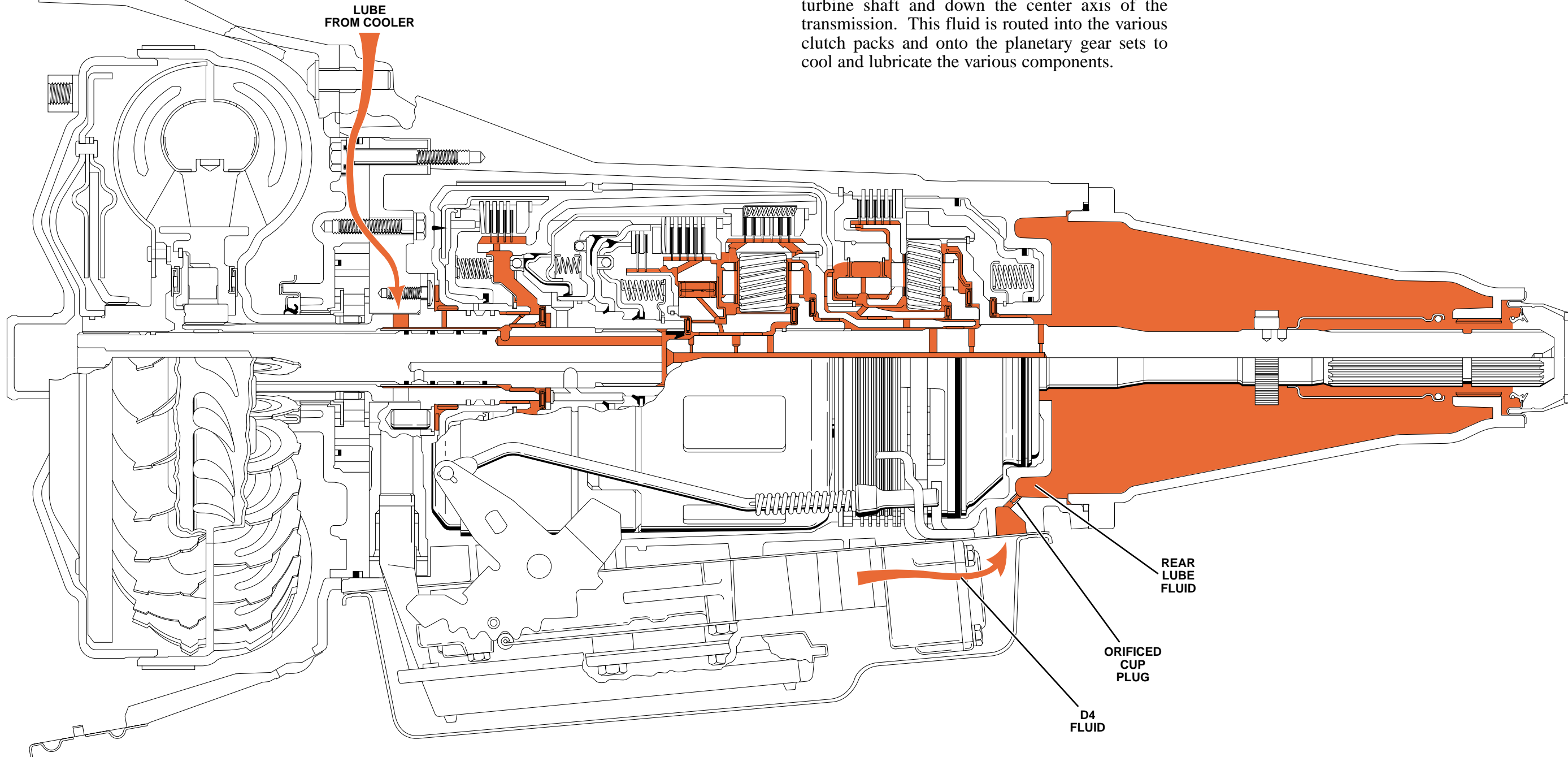

Figure 94

COOLER AND LUBRICATION CIRCUITS

To maintain proper transmission fluid temperature, the fluid is routed to the transmission fluid cooler located in the vehicle radiator. After the fluid is cooled it is routed back to the transmission and into the lubrication fluid circuit. Lube fluid is routed through the oil pump assembly, into the turbine shaft and down the center axis of the transmission. This fluid is routed into the various clutch packs and onto the planetary gear sets to cool and lubricate the various components.

The rear of the transmission is lubricated by D4 fluid feeding the rear lube fluid circuit through an orifice cup plug (#24). Rear lube fluid is routed into the transmission case extension housing (31) to cool and lubricate the bushings and components in the housing.



Bushing and Bearing Locations

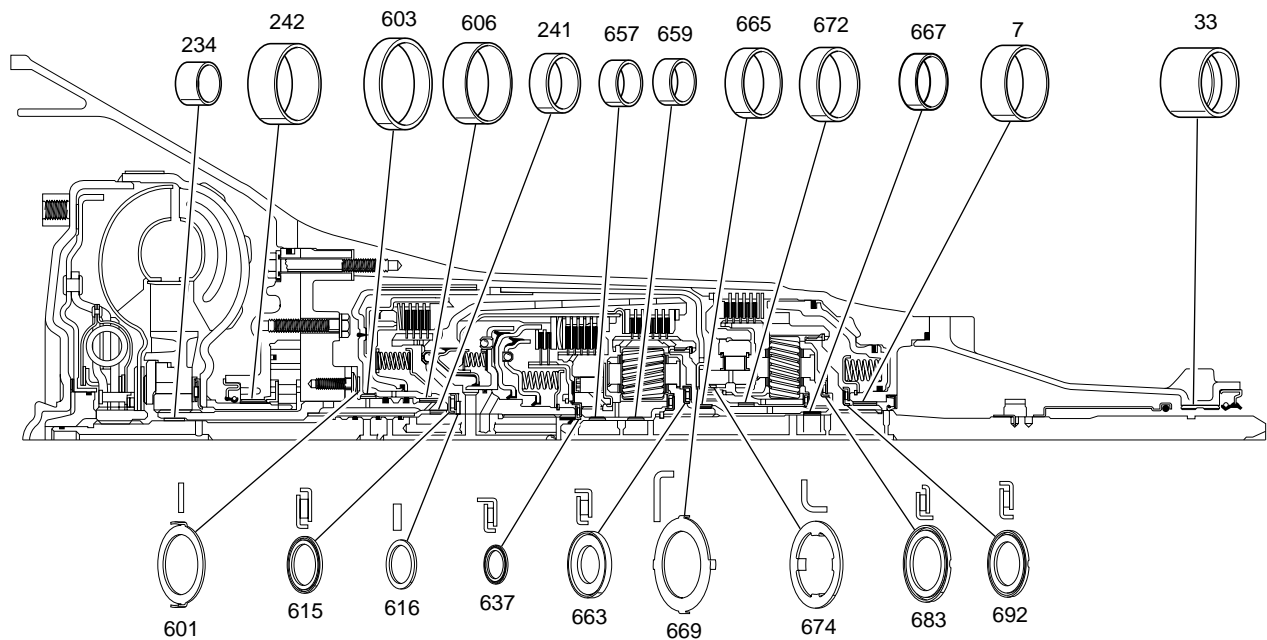

- | | | | |
|-----|---|-----|---|
| 7 | CASE BUSHING | 657 | INPUT SUN GEAR BUSHING (FRONT) |
| 33 | CASE EXTENSION BUSHING | 659 | INPUT SUN GEAR BUSHING (REAR) |
| 234 | STATOR SHAFT BUSHING (FRONT) | 663 | THRUST BEARING ASSEMBLY (INPUT CARRIER TO REACTION SHAFT) |
| 241 | STATOR SHAFT BUSHING (REAR) | 665 | REACTION CARRIER SHAFT BUSHING (FRONT) |
| 242 | OIL PUMP BODY BUSHING | 667 | REACTION CARRIER SHAFT BUSHING (REAR) |
| 601 | THRUST WASHER (PUMP TO DRUM) | 669 | THRUST WASHER (REACTION SHAFT/SHELL) |
| 603 | REVERSE INPUT CLUTCH BUSHING (FRONT) | 672 | REACTION GEAR BUSHING |
| 606 | REVERSE INPUT CLUTCH BUSHING (REAR) | 674 | THRUST WASHER (RACE/REACTION SHELL) |
| 615 | STATOR SHAFT/ SELECTIVE WASHER BEARING ASSEMBLY | 683 | THRUST BEARING ASSEMBLY (REACTION CARRIER/ SUPPORT) |
| 616 | THRUST WASHER (SELECTIVE) | 692 | REACTION GEAR SUPPORT TO CASE BEARING |
| 637 | INPUT SUN GEAR BEARING ASSEMBLY | | |

Seal Locations

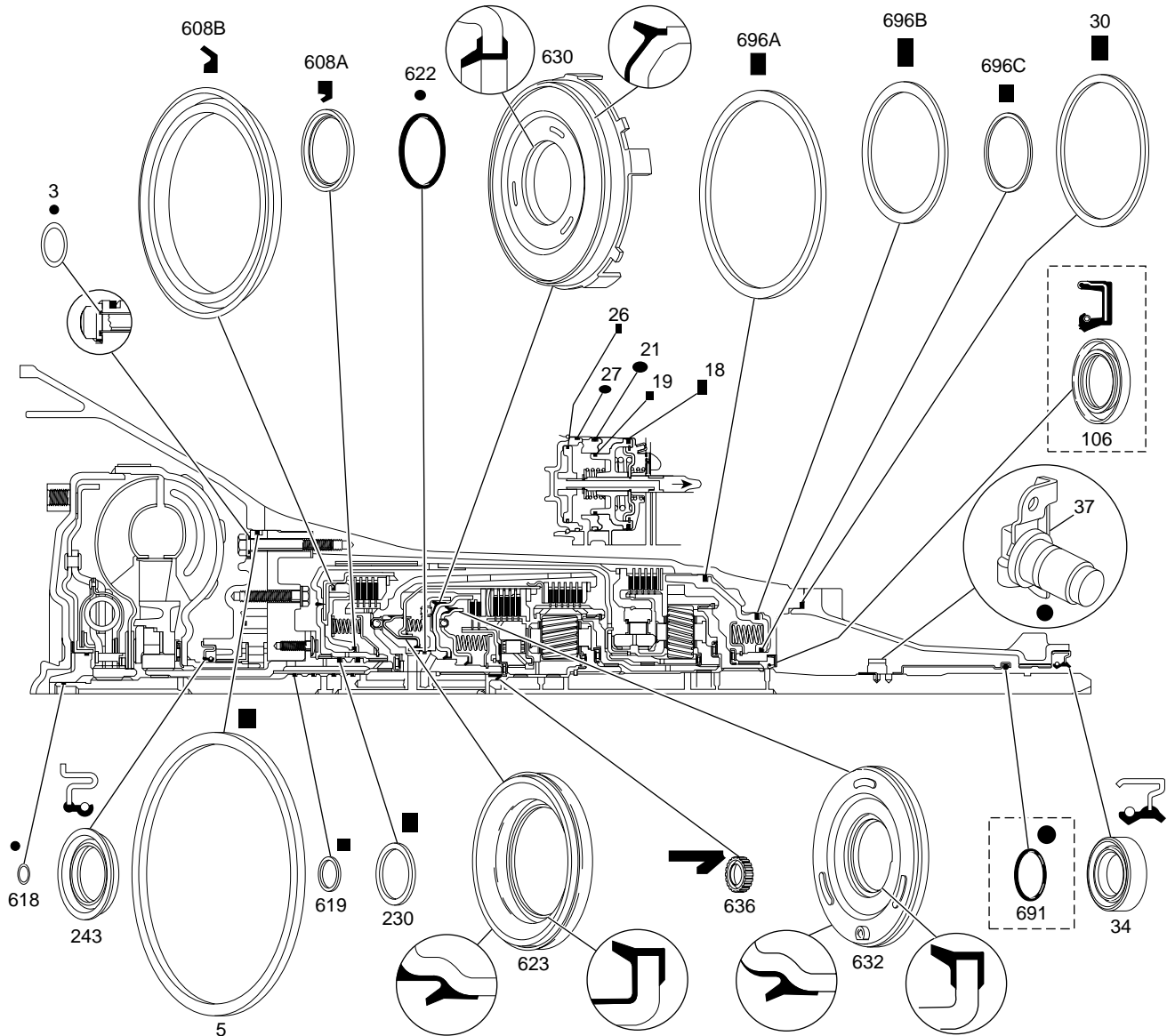

- | | | | |
|-----|--|------|---|
| 3 | PUMP TO CASE BOLT O-RING | 608A | REVERSE INPUT CLUTCH SEAL (INNER) |
| 5 | OIL SEAL (PUMP TO CASE) | 608B | REVERSE INPUT CLUTCH SEAL (OUTER) |
| 18 | OIL SEAL RING (2ND APPLY PISTON - OUTER) | 618 | O-RING SEAL (TURBINE SHAFT/ SELECTIVE WASHER) |
| 19 | OIL SEAL RING (2ND APPLY PISTON - INNER) | 619 | OIL SEAL RING (SOLID) |
| 21 | O-RING SEAL | 622 | INPUT TO FORWARD HOUSING O-RING SEAL |
| 26 | OIL SEAL RING (4TH APPLY PISTON - OUTER) | 623 | 3RD AND 4TH CLUTCH PISTON |
| 27 | O-RING SEAL (2-4 SERVO COVER) | 630 | FORWARD CLUTCH PISTON |
| 30 | CASE EXTENSION TO CASE SEAL | 632 | OVERRUN CLUTCH PISTON |
| 34 | CASE EXTENSION OIL SEAL ASSEMBLY | 636 | INPUT HOUSING TO OUTPUT SHAFT SEAL |
| 37 | O-RING SEAL (ITSS TO CASE EXTENSION) | 691 | OUTPUT SHAFT SEAL (MODEL DEPENDENT) |
| 106 | CASE OIL SEAL ASSEMBLY (Y CAR ONLY) | 696A | LOW AND REVERSE CLUTCH SEAL (OUTER) |
| 230 | OIL SEAL RING (STATOR SHAFT) | 696B | LOW AND REVERSE CLUTCH SEAL (CENTER) |
| 243 | OIL SEAL ASSEMBLY | 696C | LOW AND REVERSE CLUTCH SEAL (INNER) |

WH338497-4L60-E

ILLUSTRATED PARTS LIST

Case and Associated Parts (1 of 2)

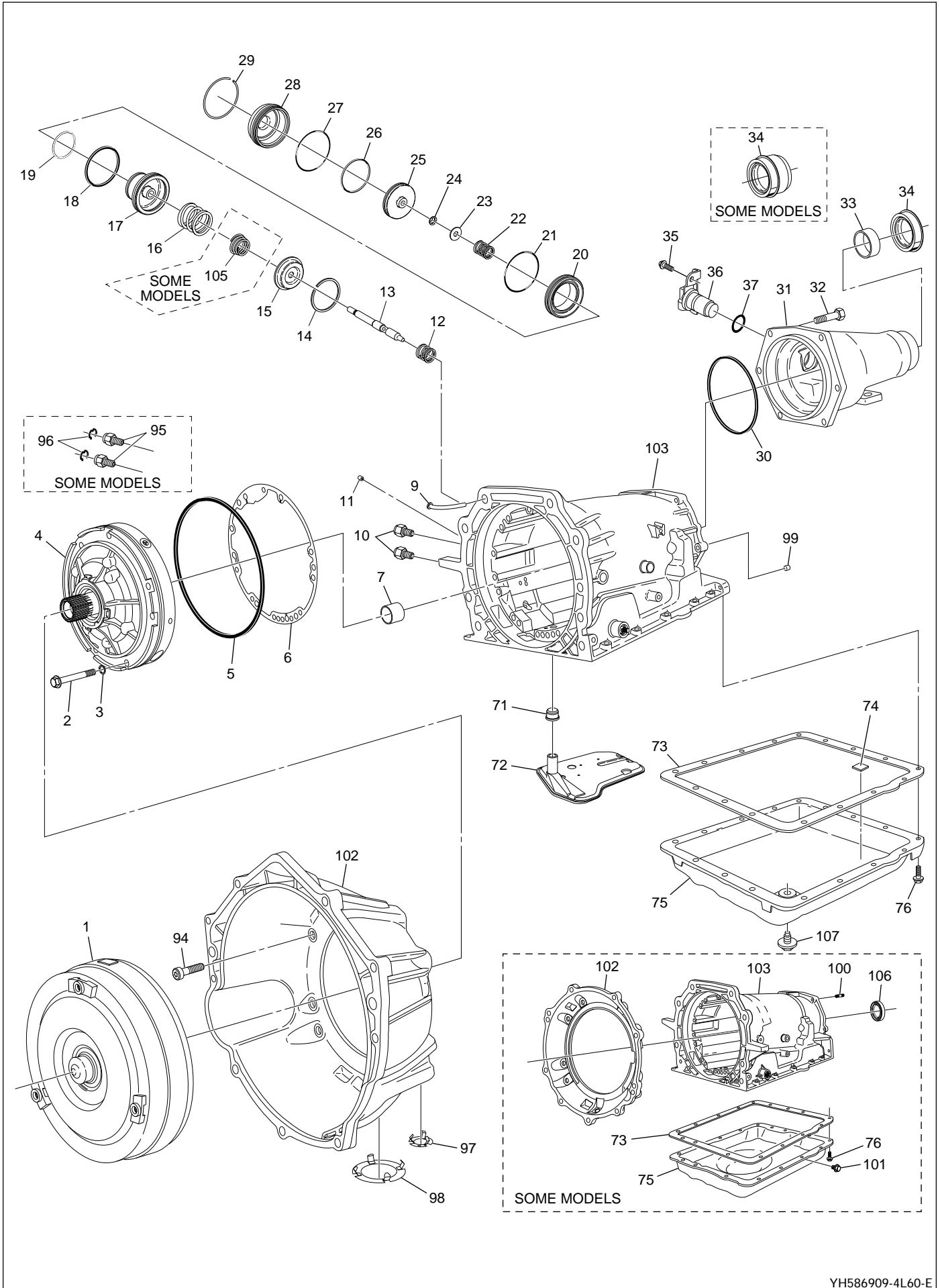

Case and Associated Parts (1 of 2) Legend

1	TORQUE CONVERTER ASSEMBLY (MODEL DEPENDENT)	31	CASE EXTENSION (MODEL DEPENDENT)
2	PUMP TO CASE BOLT	32	CASE EXTENSION TO CASE BOLT
3	PUMP TO CASE BOLT O-RING	33	CASE EXTENSION BUSHING
4	OIL PUMP ASSEMBLY	34	CASE EXTENSION OIL SEAL ASSEMBLY (MODEL DEPENDENT)
5	OIL SEAL (PUMP TO CASE)	35	SPEED SENSOR RETAINING BOLT
6	PUMP COVER TO CASE GASKET	36	INTERNAL TRANSMISSION SPEED SENSOR
7	CASE BUSHING	37	O-RING SEAL (ITSS TO CASE EXTENSION)
9	TRANSMISSION VENT ASSEMBLY	71	FILTER SEAL
10	OIL COOLER PIPE CONNECTOR (MODEL DEPENDENT)	72	TRANSMISSION OIL FILTER ASSEMBLY (MODEL DEPENDENT)
11	CASE SERVO PLUG	73	TRANSMISSION OIL PAN GASKET
12	SERVO RETURN SPRING	74	CHIP COLLECTOR MAGNET
13	2ND APPLY PISTON PIN	75	TRANSMISSION OIL PAN (MODEL DEPENDENT)
14	RETAINER RING (2ND APPLY PISTON)	76	TRANSMISSION OIL PAN SCREW
15	SERVO CUSHION SPRING RETAINER	94	CONVERTER HOUSING TO CASE BOLT
16	SERVO CUSHION SPRING (OUTER)	95	OIL COOLER QUICK CONNECTOR (MODEL DEPENDENT)
17	2ND APPLY PISTON	96	OIL COOLER QUICK CONNECT CLIP (MODEL DEPENDENT)
18	OIL SEAL RING (2ND APPLY PISTON - OUTER)	97	CONVERTER HOUSING ACCESS HOLE PLUG (MODEL DEPENDENT)
19	OIL SEAL RING (2ND APPLY PISTON - INNER)	98	CONVERTER BOLT INSPECTION PLATE (MODEL DEPENDENT)
20	SERVO PISTON HOUSING (INNER)	99	CUP D4 ORIFICE PLUG
21	O-RING SEAL	100	A/TRANS. CASE STUD (Y-CAR ONLY)
22	SERVO APPLY PIN SPRING	101	A/TRANS. OIL PAN PLUG ASSEMBLY (Y-CAR ONLY)
23	SERVO APPLY PIN WASHER	102	CONVERTER HOUSING (MODEL DEPENDENT)
24	RETAINER RING (APPLY PIN)	103	MAIN CASE SECTION (MODEL DEPENDENT)
25	4TH APPLY PISTON	105	SERVO CUSHION SPRING (INNER) (MODEL DEPENDENT)
26	OIL SEAL RING (4TH APPLY PISTON - OUTER)	106	CASE OIL SEAL ASSEMBLY (Y-CAR ONLY)
27	O-RING SEAL (2-4 SERVO COVER)	107	PLUG ASSEMBLY A/TRANS. OIL PAN HEX HEAD (C/K TRUCK ONLY)
28	2-4 SERVO COVER		
29	SERVO COVER RETAINING RING		
30	CASE EXTENSION TO CASE SEAL		

Case and Associated Parts (2 of 2)

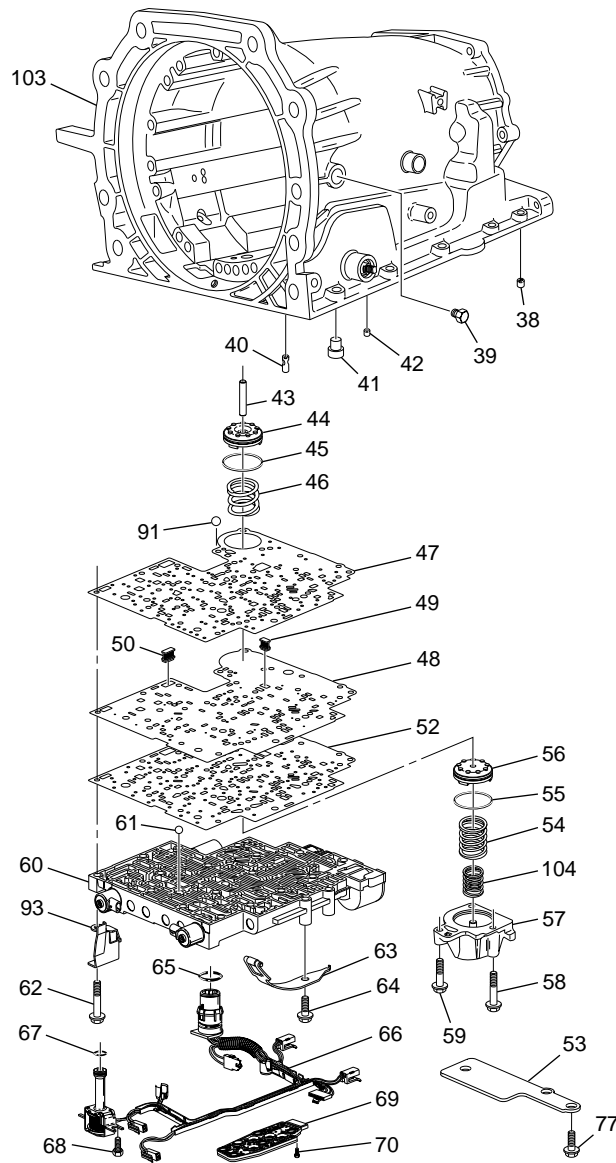

- | | | | |
|----|---|-----|---|
| 38 | TRANSMISSION CASE PLUG (ACCUMULATOR BLEED) | 58 | ACCUMULATOR COVER BOLT |
| 39 | PRESSURE PLUG | 59 | ACCUMULATOR COVER BOLT |
| 40 | 3RD ACCUMULATOR RETAINER AND BALL ASSEMBLY (#7) | 60 | CONTROL VALVE BODY ASSEMBLY |
| 41 | BAND ANCHOR PIN | 61 | CHECKBALL (#2, 3, 4, 5, 6, 8, 12) |
| 42 | RETAINER AND BALL ASSEMBLY (DOUBLE ORIFICE) (#10) | 62 | VALVE BODY BOLT |
| 43 | ACCUMULATOR PISTON PIN | 63 | MANUAL DETENT SPRING ASSEMBLY |
| 44 | 3-4 ACCUMULATOR PISTON | 64 | MANUAL DETENT SPRING BOLT |
| 45 | OIL SEAL RING (3-4 ACCUMULATOR PISTON) | 65 | WIRING HARNESS PASS-THRU CONNECTOR O-RING SEAL |
| 46 | 3-4 ACCUMULATOR SPRING (MODEL DEPENDENT) | 66 | WIRING HARNESS SOLENOID ASSEMBLY |
| 47 | SPACER PLATE TO CASE GASKET | 67 | O-RING SEAL (SOLENOID) |
| 48 | VALVE BODY SPACER PLATE | 68 | HEX WASHER HEAD BOLT (SOLENOID) |
| 49 | SHIFT SOLENOIDS SCREEN | 69 | TRANSMISSION FLUID PRESSURE MANUAL VALVE POSITION SWITCH ASSEMBLY |
| 50 | PRESSURE CONTROL SOLENOID SCREEN | 70 | PRESSURE SWITCH ASSEMBLY BOLT |
| 52 | SPACER PLATE TO VALVE BODY GASKET | 77 | SPACER PLATE SUPPORT BOLT |
| 53 | SPACER PLATE SUPPORT PLATE | 91 | NUMBER 1 CHECKBALL |
| 54 | 1-2 ACCUMULATOR SPRING (OUTER) | 93 | DIPSTICK STOP BRACKET (MODEL DEPENDENT) |
| 55 | OIL SEAL RING (1-2 ACCUMULATOR) | 103 | MAIN CASE SECTION (MODEL DEPENDENT) |
| 56 | 1-2 ACCUMULATOR PISTON | 104 | 1-2 ACCUMULATOR SPRING (INNER) |
| 57 | 1-2 ACCUMULATOR COVER AND PIN ASSEMBLY | | |

YH283778-4L60-E

Oil Pump Assembly

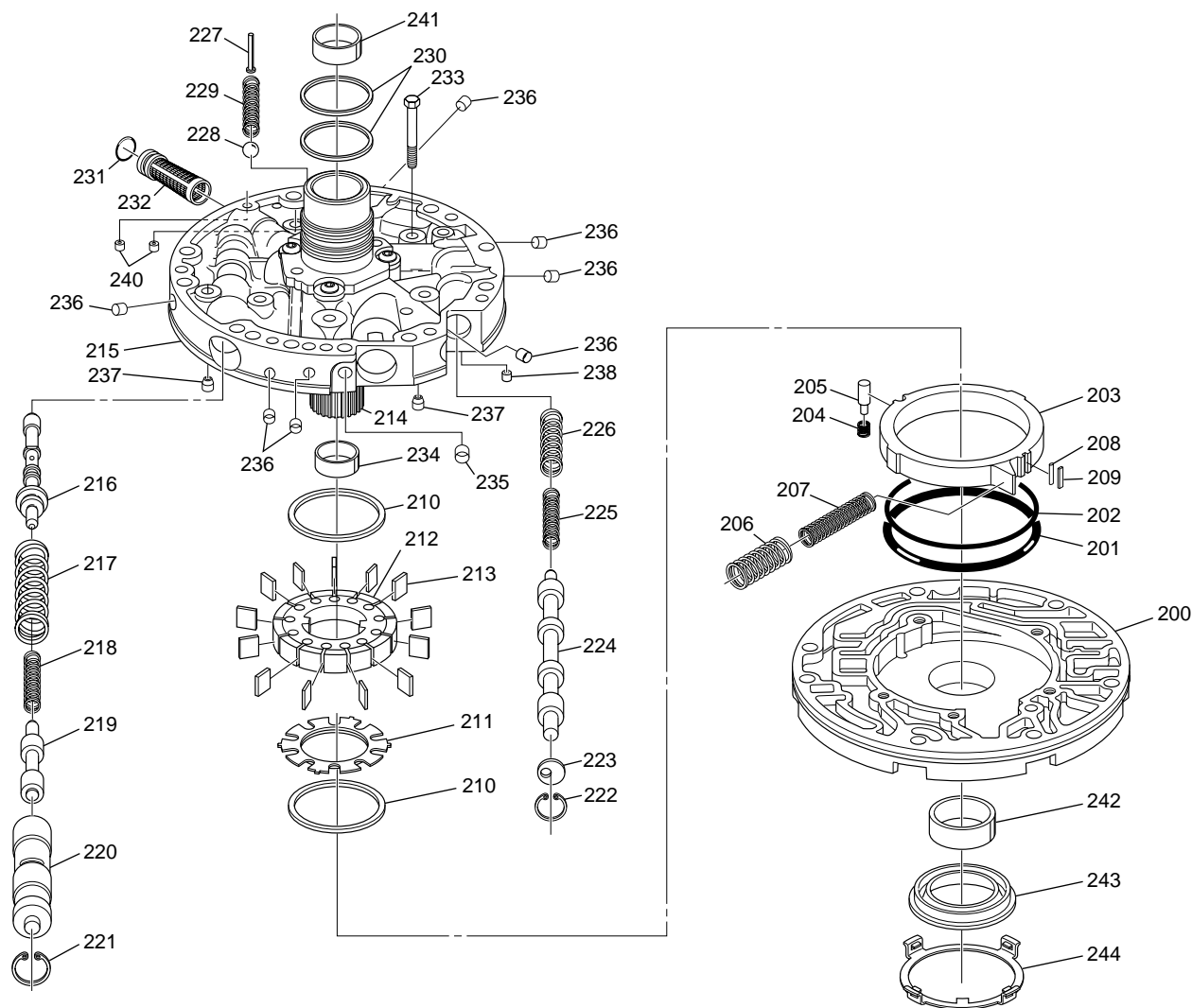

- 200 PUMP BODY
- 201 OIL SEAL RING (SLIDE TO WEAR PLATE)
- 202 O-RING SEAL (SLIDE SEAL BACK-UP)
- 203 PUMP SLIDE
- 204 PIVOT PIN SPRING
- 205 PIVOT SLIDE PIN
- 206 PUMP SLIDE SPRING (OUTER)
- 207 PUMP SLIDE SPRING (INNER)
- 208 PUMP SLIDE SEAL SUPPORT
- 209 PUMP SLIDE SEAL
- 210 PUMP VANE RING
- 211 ROTOR GUIDE
- 212 OIL PUMP ROTOR
- 213 PUMP VANE
- 214 STATOR SHAFT
- 215 PUMP COVER
- 216 PRESSURE REGULATOR VALVE
- 217 PRESSURE REGULATOR VALVE SPRING
- 218 PRESSURE REGULATOR ISOLATOR SPRING
- 219 REVERSE BOOST VALVE
- 220 REVERSE BOOST VALVE SLEEVE
- 221 OIL PUMP REVERSE BOOST VALVE RETAINING RING

- 222 OIL PUMP CONVERTER CLUTCH VALVE RETAINING RING
- 223 STOP VALVE
- 224 CONVERTER CLUTCH VALVE
- 225 CONVERTER CLUTCH VALVE SPRING (INNER)
- 226 CONVERTER CLUTCH VALVE SPRING (OUTER)
- 227 PRESSURE RELIEF BOLT RIVET
- 228 PRESSURE RELIEF BALL
- 229 PRESSURE RELIEF SPRING
- 230 OIL SEAL RING (STATOR SHAFT)
- 231 OIL PUMP COVER SCREEN SEAL
- 232 OIL PUMP COVER SCREEN
- 233 COVER TO BODY BOLT
- 234 STATOR SHAFT BUSHING (FRONT)
- 235 OIL PUMP COVER PLUG (FWD CLUTCH FEED)
- 236 OIL PUMP COVER PLUG
- 237 CHECK VALVE RETAINER AND BALL ASSEMBLY
- 238 CONVERTER CLUTCH SIGNAL ORIFICE (CUP PLUG)
- 240 CUP ORIFICE PLUG
- 241 STATOR SHAFT BUSHING (REAR)
- 242 PUMP BODY BUSHING
- 243 OIL SEAL ASSEMBLY
- 244 FRONT HELIX RETAINER

XH405105-4L60-E

Figure 100

Control Valve Body Assembly (1 of 2)

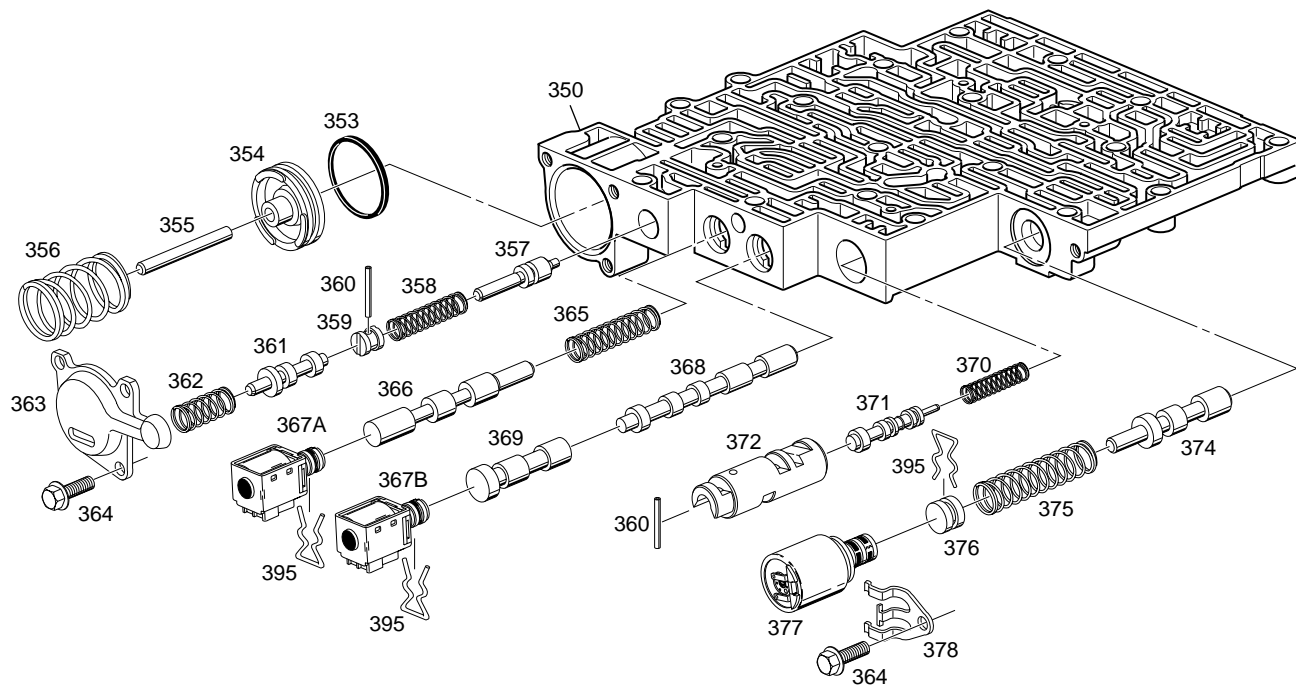

- | | | | |
|-----|--------------------------------|------|------------------------------------|
| 350 | CONTROL VALVE BODY | 366 | 1-2 SHIFT VALVE |
| 353 | FORWARD ACCUMULATOR OIL SEAL | 367A | 1-2 SHIFT SOLENOID VALVE |
| 354 | FORWARD ACCUMULATOR PISTON | 367B | 2-3 SHIFT SOLENOID VALVE |
| 355 | FORWARD ACCUMULATOR PIN | 368 | 2-3 SHIFT VALVE |
| 356 | FORWARD ACCUMULATOR SPRING | 369 | 2-3 SHUTTLE VALVE |
| 357 | FORWARD ABUSE VALVE | 370 | 1-2 ACCUMULATOR VALVE SPRING |
| 358 | FORWARD ABUSE VALVE SPRING | 371 | 1-2 ACCUMULATOR VALVE |
| 359 | BORE PLUG | 372 | 1-2 ACCUMULATOR VALVE SLEEVE |
| 360 | COILED SPRING PIN | 374 | ACTUATOR FEED LIMIT VALVE |
| 361 | LOW OVERRUN VALVE | 375 | ACTUATOR FEED LIMIT VALVE SPRING |
| 362 | LOW OVERRUN VALVE SPRING | 376 | BORE PLUG |
| 363 | FORWARD ACCUMULATOR COVER | 377 | PRESSURE CONTROL SOLENOID VALVE |
| 364 | FORWARD ACCUMULATOR COVER BOLT | 378 | PRESSURE CONTROL SOLENOID RETAINER |
| 365 | 1-2 SHIFT VALVE SPRING | 395 | BORE PLUG AND SOLENOID RETAINER |

XH405111-4L60-E

Control Valve Body Assembly (2 of 2)

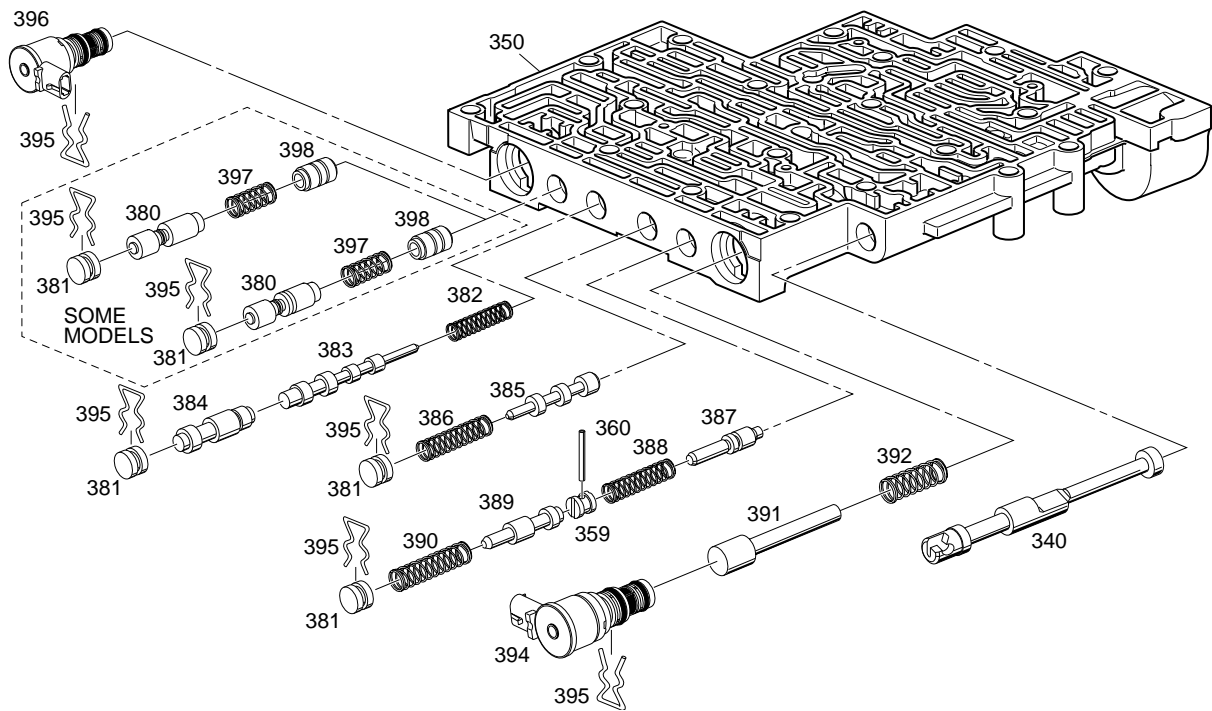

- | | | | |
|-----|---|-----|--|
| 340 | MANUAL VALVE | 387 | REVERSE ABUSE VALVE |
| 350 | CONTROL VALVE BODY | 388 | REVERSE ABUSE VALVE SPRING |
| 359 | BORE PLUG | 389 | 3-2 DOWNSHIFT VALVE |
| 360 | COILED SPRING PIN | 390 | 3-2 DOWNSHIFT VALVE SPRING |
| 380 | REGULATOR APPLY VALVE (MODEL DEPENDENT) | 391 | 3-2 CONTROL VALVE |
| 381 | BORE PLUG | 392 | 3-2 CONTROL VALVE SPRING |
| 382 | 4-3 SEQUENCE VALVE SPRING | 394 | 3-2 CONTROL SOLENOID VALVE |
| 383 | 4-3 SEQUENCE VALVE | 395 | BORE PLUG AND SOLENOID RETAINER |
| 384 | 3-4 RELAY VALVE | 396 | TCC PWM SOLENOID VALVE |
| 385 | 3-4 SHIFT VALVE | 397 | REGULATOR APPLY SPRING (MODEL DEPENDENT) |
| 386 | 3-4 SHIFT VALVE SPRING | 398 | ISOLATOR VALVE (MODEL DEPENDENT) |

XH405114-4L60-E

Figure 102

Internal Components (1 of 2)

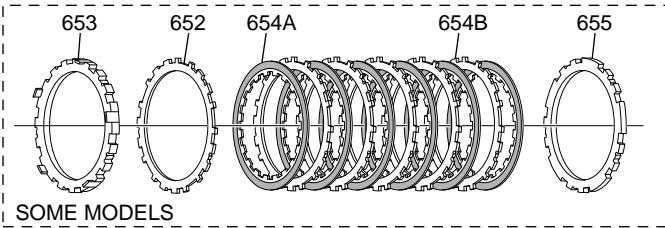
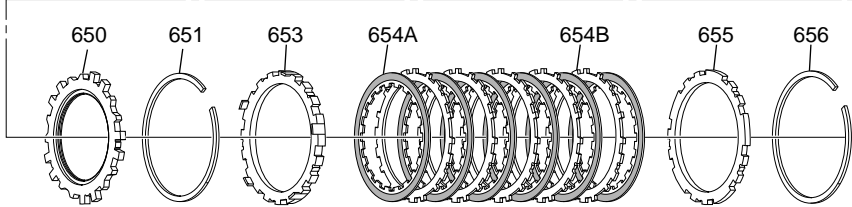
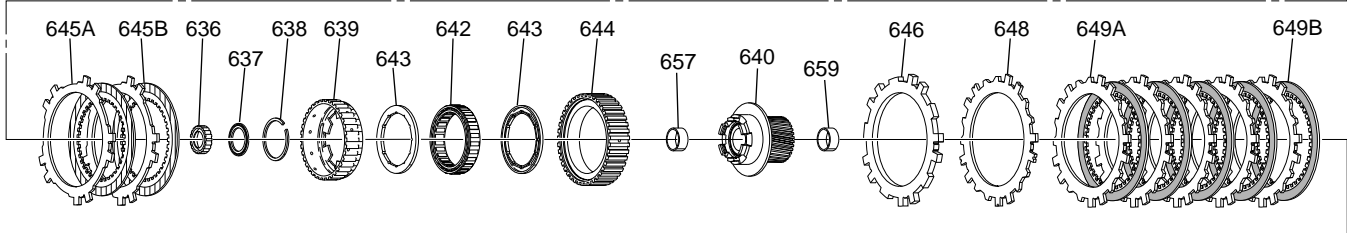
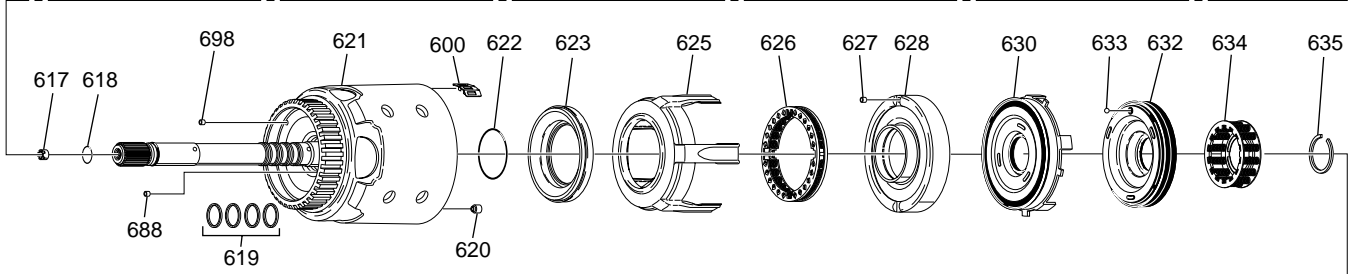
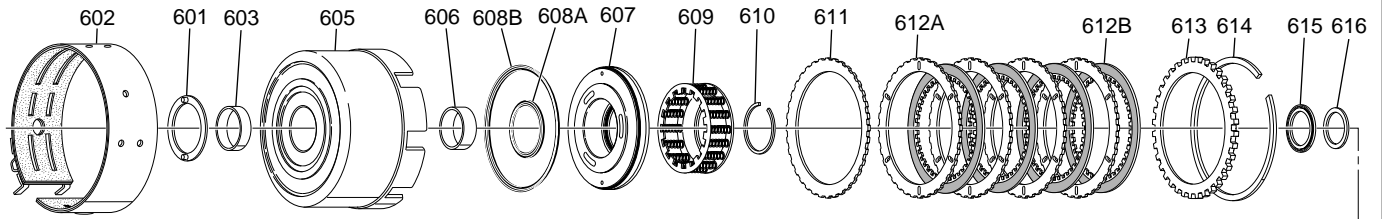

Internal Components (1 of 2) Legend

600	3-4 CLUTCH BOOST SPRING ASSEMBLY (5)	632	OVERRUN CLUTCH PISTON
601	THRUST WASHER (PUMP TO DRUM)	633	OVERRUN CLUTCH BALL
602	2-4 BAND ASSEMBLY	634	OVERRUN CLUTCH SPRING ASSEMBLY
603	REVERSE INPUT CLUTCH BUSHING (FRONT)	635	OVERRUN CLUTCH SPRING RETAINER SNAP RING
605	REVERSE INPUT CLUTCH HOUSING AND DRUM ASSEMBLY	636	INPUT HOUSING TO OUTPUT SHAFT SEAL
606	REVERSE INPUT CLUTCH BUSHING (REAR)	637	INPUT SUN GEAR BEARING ASSEMBLY
607	REVERSE INPUT CLUTCH PISTON ASSEMBLY	638	OVERRUN CLUTCH HUB RETAINING SNAP RING
608A	REVERSE INPUT CLUTCH SEAL (INNER)	639	OVERRUN CLUTCH HUB
608B	REVERSE INPUT CLUTCH SEAL (OUTER)	640	FORWARD SPRAG CLUTCH INNER RACE AND INPUT SUN GEAR ASSEMBLY
609	REVERSE INPUT CLUTCH SPRING ASSEMBLY	642	FORWARD SPRAG ASSEMBLY
610	REVERSE INPUT CLUTCH SPRING RETAINER RING	643	SPRAG ASSEMBLY RETAINER RING
611	REVERSE INPUT CLUTCH PLATE (BELLEVILLE)	644	FORWARD CLUTCH RACE (OUTER)
612A	REVERSE INPUT CLUTCH TURBULATOR PLATE (STEEL)	645A	OVERRUN CLUTCH PLATE (STEEL)
612B	REVERSE INPUT CLUTCH PLATE ASSEMBLY (FIBER)	645B	OVERRUN CLUTCH PLATE ASSEMBLY (FIBER)
613	REVERSE INPUT CLUTCH BACKING PLATE (SELECTIVE)	646	FORWARD CLUTCH PLATE (APPLY)
614	REVERSE INPUT CLUTCH RETAINING RING	648	FORWARD CLUTCH PLATE (WAVED)
615	STATOR SHAFT/ SELECTIVE WASHER BEARING ASSEMBLY	649A	FORWARD CLUTCH PLATE (STEEL)
616	THRUST WASHER (SELECTIVE)	649B	FORWARD CLUTCH PLATE ASSEMBLY (FIBER)
617	CHECK VALVE RETAINER AND BALL ASSEMBLY	650	FORWARD CLUTCH BACKING PLATE (SELECTIVE)
618	O-RING SEAL (TURBINE SHAFT/ SELECTIVE WASHER) (MODEL DEPENDENT)	651	FORWARD CLUTCH BACKING PLATE RETAINER RING
619	OIL SEAL RING (SOLID)	652	3RD AND 4TH CLUTCH PLATE (STEEL) (2.2L ENGINE ONLY)
620	RETAINER AND CHECKBALL ASSEMBLY	653	3RD AND 4TH CLUTCH APPLY PLATE (STEPPED)
621	INPUT HOUSING AND SHAFT ASSEMBLY (MODEL DEPENDENT)	654A	3RD AND 4TH CLUTCH PLATE ASSEMBLY (FIBER) (QUANTITY MODEL DEPENDENT)
622	O-RING SEAL INPUT TO FORWARD CLUTCH HOUSING	654B	3RD AND 4TH CLUTCH PLATE (STEEL) (QUANTITY MODEL DEPENDENT)
623	3RD AND 4TH CLUTCH PISTON	655	3RD AND 4TH CLUTCH BACKING PLATE (SELECTIVE) (MODEL DEPENDENT)
625	3RD AND 4TH CLUTCH RING (APPLY)	656	3RD AND 4TH CLUTCH BACKING PLATE RETAINER RING
626	3RD AND 4TH CLUTCH SPRING ASSEMBLY	657	INPUT SUN GEAR FRONT BUSHING
627	FORWARD CLUTCH HOUSING RETAINER AND BALL ASSEMBLY	659	INPUT SUN GEAR REAR BUSHING
628	FORWARD CLUTCH HOUSING	688	CUP PLUG
630	FORWARD CLUTCH PISTON	698	ORIFICED CUP PLUG

Internal Components (2 of 2)

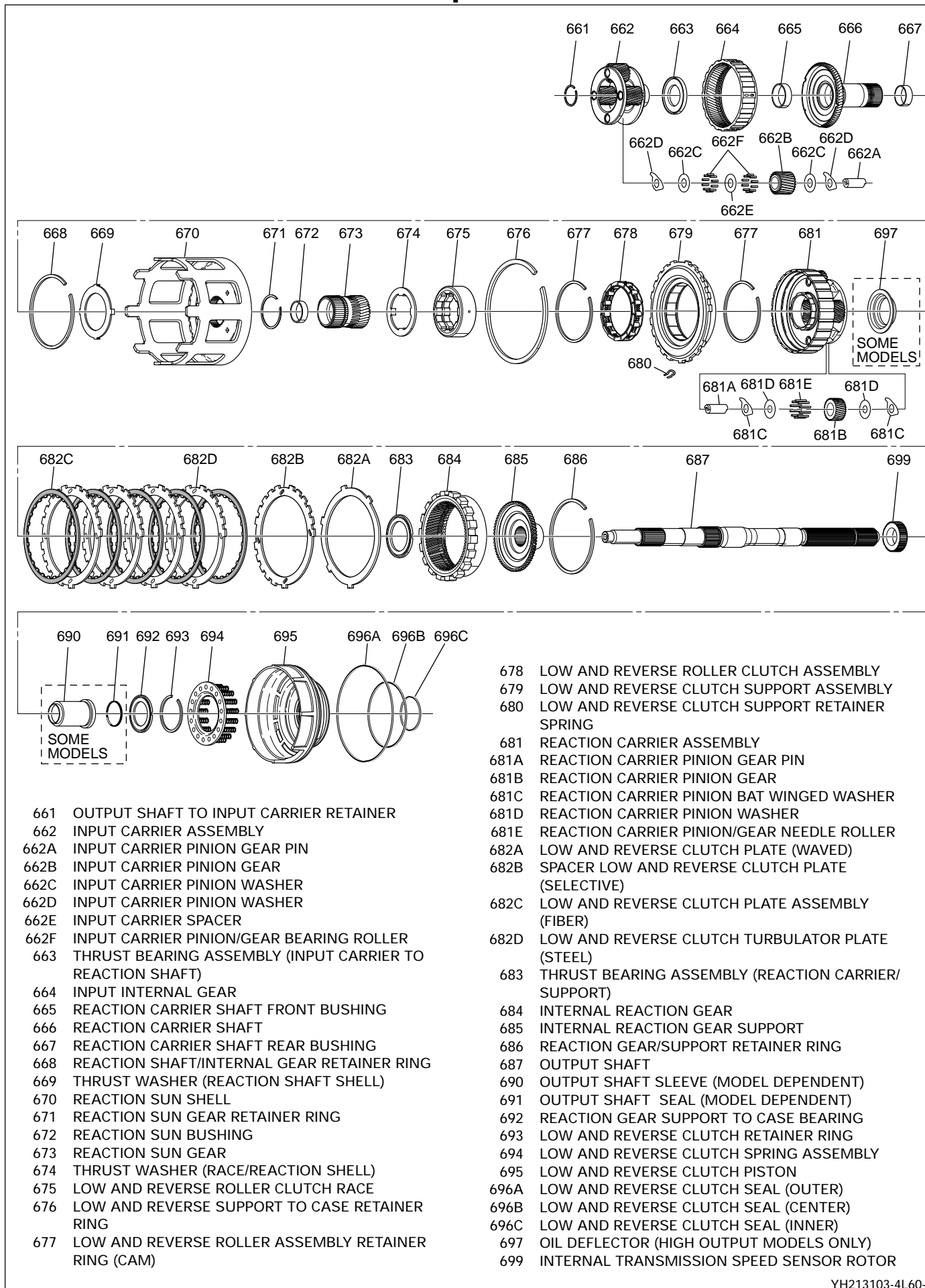

YH213103-4L60-E

Parking Pawl and Actuator Assembly

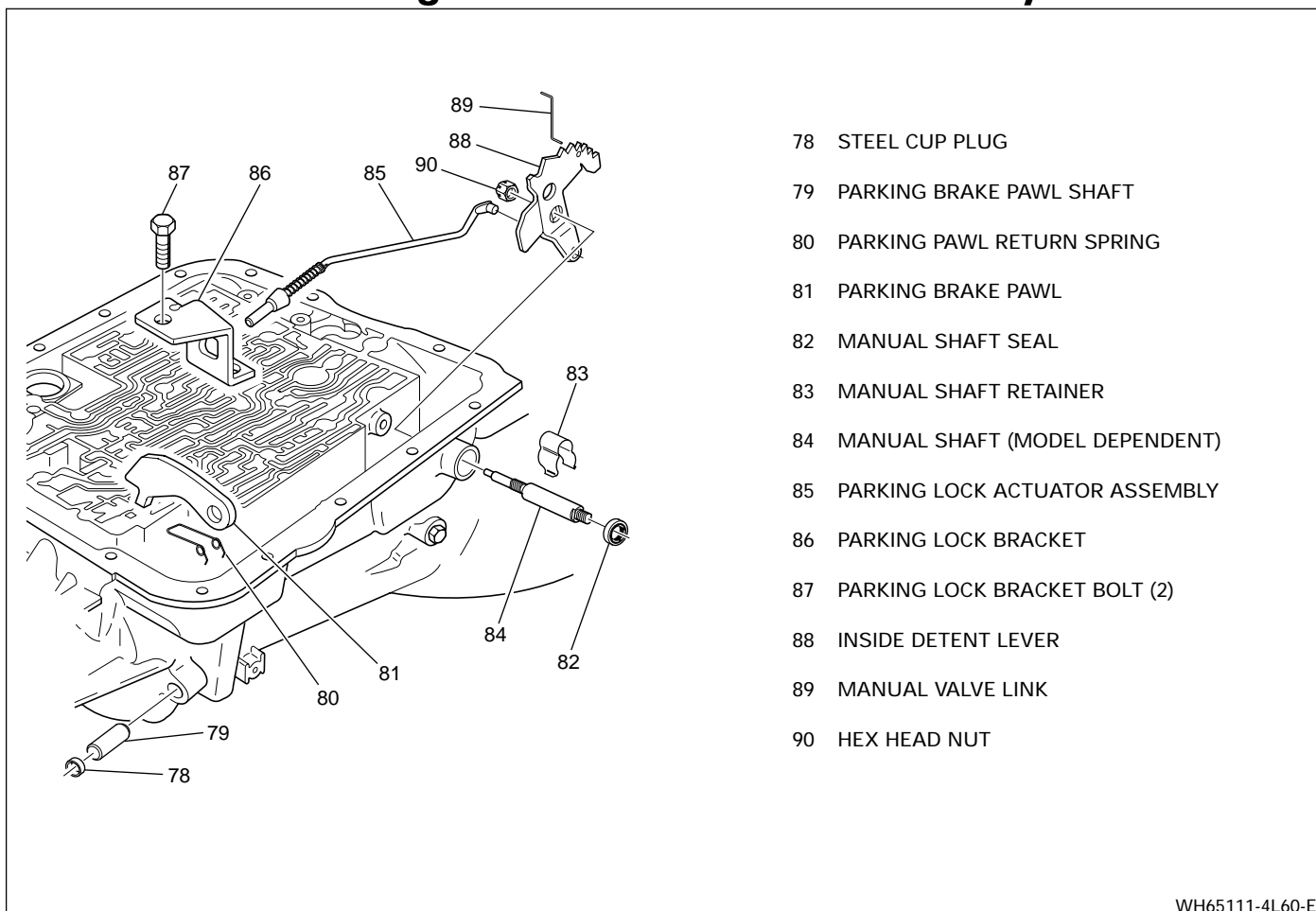

- 78 STEEL CUP PLUG
- 79 PARKING BRAKE PAWL SHAFT
- 80 PARKING PAWL RETURN SPRING
- 81 PARKING BRAKE PAWL
- 82 MANUAL SHAFT SEAL
- 83 MANUAL SHAFT RETAINER
- 84 MANUAL SHAFT (MODEL DEPENDENT)
- 85 PARKING LOCK ACTUATOR ASSEMBLY
- 86 PARKING LOCK BRACKET
- 87 PARKING LOCK BRACKET BOLT (2)
- 88 INSIDE DETENT LEVER
- 89 MANUAL VALVE LINK
- 90 HEX HEAD NUT

WH65111-4L60-E

Figure 105

BASIC SPECIFICATIONS

HYDRA-MATIC 4L60-E TRANSMISSION

Produced at: Romulus, Michigan
Toledo, Ohio
U.S.A.
Mexico

RPO M30

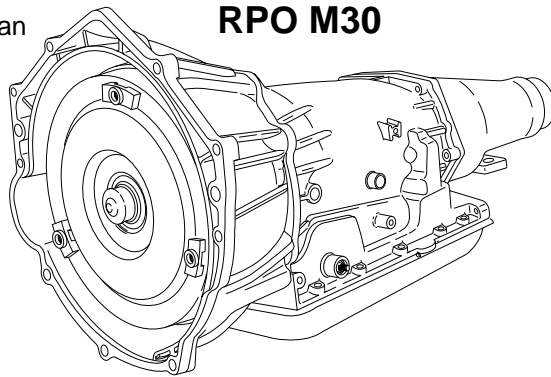

Vehicles used in:

	DIVISION	MODEL
C/K Truck	Chevrolet/GMC	Pickup/Suburban
F	Chevrolet/Pontiac	Camaro/Firebird
G Van	Chevrolet/GMC	Express/Savana
M/L Van	Chevrolet/GMC	Astro/Safari
S/T Truck	Chevrolet/GMC	S10/Sonoma
Y	Chevrolet	Corvette

HYDRA-MATIC 4L60-E
(FOUR-SPEED)

Transmission Drive

Rear Wheel Drive
4-Wheel Drive
All Wheel Drive

Transmission Type

4L60-E = 4: Four Speed
L: Longitudinal Mount
60: Product Series
E: Electronically Controlled

Automatic Overdrive with a Torque Converter Clutch Assembly.

Current Engine Range

2.5 L to 5.7 L Gasoline
6.2 L Diesel

Control Systems

Shift Pattern – (2) Two-way on/off solenoids
Shift Quality – Pressure Control Solenoid
3-2 Control Solenoid
Torque Converter Clutch – Pulse Width Modulated solenoid control

Gear Ratios

1st 3.059
2nd 1.625
3rd 1.000
4th 0.696
Rev 2.294

Maximum Engine Torque

475 N•m (350 lb ft)

Maximum Gearbox Torque

910 N•m (670 lb ft)

Maximum Shift Speed

1-2 6,000 RPM
2-3 6,000 RPM
3-4 6,000 RPM

Maximum Gross Vehicle Weight

3,900 kg (8,600 lb)

Transmission Fluid Type

Dexron® III

Transmission Fluid Capacities (Approximate)

245 mm Converter (Dry): 7.9 L (8.4 qt)
258 mm Converter (Dry): 8.8 L (9.3 qt)
298 mm Converter (Dry): 10.6 L (11.2 qt)
300 mm Converter (Dry): 10.6 L (11.2 qt)

Transmission Weight

245 mm Converter (Dry): 65.4 kg (144.30 lb)
(Wet): 72.4 kg (159.55 lb)

258 mm Converter (Dry): 79.9 kg (176.60 lb)
(Wet): 89.2 kg (197.70 lb)

298 mm Converter (Dry): 70.5 kg (155.70 lb)
(Wet): 80.5 kg (176.16 lb)

300 mm Converter (Dry): 70.5 kg (155.70 lb)
(Wet): 80.5 kg (176.16 lb)

Converter Sizes Available

245, 258, 298 and 300 mm Converter (Reference)

Converter Bolt Circle Diameters

For 245 and 258 mm Converter – 247.65 mm (Reference)
For 298 mm Converter – 273.05 mm (Reference)
For 300 mm Converter – 275.05 mm (Reference)

Converter Stall Torque Ratio Range

For 245 mm Converter – 1.63 to 2.70
For 258 mm Converter – 1.65 to 2.07
For 298 mm Converter – 1.84 to 2.34
For 300 mm Converter – 1.84 to 2.34

Converter “K” Factor Range

For 245 mm Converter – 122 to 240
For 258 mm Converter – 110 to 179
For 298 mm Converter – 100 to 140
For 300 mm Converter – 100 to 140

Not all “K” Factors are applicable across the range of Converter Stall Torque Ratios.

Transmission Packaging Information*

Engine Mounting Face to Rear of Case
593.50 mm (Reference - Less Extension)

Overall Length

Current Minimum: 756.20 mm (Reference)
Current Maximum: 778.30 mm (Reference)

Case Extension Lengths

Determined by Customer Requirements
Current Minimum: 162.70 mm (Reference)
Current Maximum: 184.80 mm (Reference)

Current Converter Housings Available

245 mm and 258 mm (Small Bell Style)
298 mm and 300 mm (Large Bell Style)

Two-Piece Case with Separate Extension

Converter Housing
Main Case

*All dimensions shown are nominal.

Seven Position Quadrant

(P, R, N, $\text{\textcircled{D}}$, D, 2, 1) / (P, R, N, $\text{\textcircled{D}}$, 3, 2, 1)

Pressure Taps Available

Line Pressure

Information may vary with application. All information, illustrations and specifications contained in this book are based on the latest product information available at the time of publication. The right is reserved to make changes at any time without notice.

HYDRA-MATIC PRODUCT DESIGNATION SYSTEM

The product designation system used for all Hydra-matic transaxles and transmissions consists of a series of numbers and letters that correspond with the special features incorporated in that product line. The first character is a number that designates the number of forward gear ranges available in that unit. For example: 4 = four forward gear ranges.

The second character is a letter that designates how the unit is mounted in the vehicle. When the letter “T” is used, it designates that the unit is transversely mounted and is used primarily for front wheel drive vehicles. The letter “L” designates that it is longitudinally mounted in the vehicle and it is used primarily for rear wheel drive vehicles. The letter “M” designates that the unit is a manual transaxle or transmission but not specific to a front or rear wheel drive vehicle application.

The third and fourth characters consists of a set of numbers, (i.e. “60”), that designate the transaxle or transmission “Series” number. This number signifies the relative torque capacity of the unit.

The fifth character designates the major features incorporated into this unit. For example, the letter “E” designates that the unit has electronic controls.

By using this method of classification, the HYDRA-MATIC 4L60-E is a 4-speed, longitudinally mounted, 60 series unit, with electronic controls.

HYDRA-MATIC 4L60-E

HYDRA-MATIC	4	L	60	E
	Number of Speeds:	Type:	Series: Based on	Major Features:
	3	T - Transverse	Relative	E - Electronic Controls
	4	L - Longitudinal	Torque	A - All Wheel Drive
	5	M - Manual	Capacity	HD - Heavy Duty
	V (CVT)			

GLOSSARY OF TECHNICAL TERMS

Accumulator: A component of the transmission that absorbs hydraulic pressure during the apply of clutch or band. Accumulators are designed to control the quality of a shift from one gear range to another.

Adaptive Learning: Programming within the PCM that automatically adjusts hydraulic pressures in order to compensate for changes in the transmission (i.e. component wear).

Applied: An apply component that is holding another component to which it is splined or assembled with. Also referred to as “engaged”.

Apply Components: Hydraulically operated clutches, servos, bands, and mechanical one-way roller or sprag clutches that drive or hold members of a planetary gear set.

Apply Plate: A steel clutch plate in a clutch pack located next to the (apply) piston.

Backing Plate: A steel plate in a clutch pack that is usually the last plate in that clutch assembly (farthest from the clutch piston).

Ball Check Valve: A spherical hydraulically controlled component (usually made of steel) that either seals or opens fluid circuits. It is also referred to as a check valve or checkball.

Band: An apply component that consists of a flexible strip of steel and friction material that wraps around a drum. When applied, it tightens around the drum and prevents the drum from rotating.

Brake Switch: An electrical device that provides signals to the Powertrain Control Module (PCM) based on the position of the brake pedal. The PCM uses this information to apply or release the torque converter clutch (TCC).

Centrifugal Force: A force that is imparted on an object (due to rotation) that increases as that object moves further away from a center/point of rotation.

Clutch Pack: An assembly of components generally consisting of clutch plates, an apply plate and a backing plate.

Clutch Plate: A hydraulically activated component that has two basic designs: (1) all steel, or (2) a steel core with friction material bonded to one or two sides of the plate.

Component: Any physical part of the transmission.

Control Valve Body: A machined metal casting that contains valve trains and other hydraulically controlled components that shift the transmission.

Coupling Speed: The speed at which a vehicle is traveling and no longer requires torque multiplication through the torque converter. At this point the stator free wheels to allow fluid leaving the turbine to flow directly to the pump. (See torque converter)

De-energize(d): To interrupt the electrical current that flows to an electronically controlled device making it electrically inoperable.

Direct Drive: A condition in a gear set where the input speed and input torque equals the output speed and torque. The gear ratio through the gear set is 1:1.

Downshift: A change in a gear ratio where input speed and torque increases.

Duty Cycle: In reference to an electronically controlled solenoid, it is the amount of time (expressed as a percentage) that current flows through the solenoid coil.

Energize(d): To supply a current to an electronically controlled device enabling it to perform its designed function.

Engine Compression Braking: A condition where compression from the engine is used with the transmission to decrease vehicle speed. Braking (slowing of the vehicle) occurs when a lower gear ratio is manually selected by moving the gear selector lever.

Exhaust: The release of fluid pressure from a hydraulic circuit. (The words exhausts and exhausting are also used and have the same intended meaning.)

Fail-Safe Mode: A condition whereby a component (i.e. engine or transmission) will partially function even if its electrical system is disabled.

Fluid: Generally considered a liquid or gas. In this publication fluid refers primarily to “transmission fluid”.

Fluid Pressure: A pressure (in this textbook usually transmission fluid) that is consistent throughout its circuit.

Force: A measurable effort that is exerted on an object (component).

Freewheeling: A condition where power is lost through a driving or holding device (i.e. roller or sprag clutches).

Friction Material: A heat and wear resistant fibrous material bonded to clutch plates and bands.

GLOSSARY OF TECHNICAL TERMS

Gear: A round, toothed device that is used for transmitting torque through other components.

Gear Range: A specific speed to torque ratio at which the transmission is operating (i.e. 1st gear, 2nd gear etc.).

Gear Ratio: Revolutions of an input gear as compared to the revolutions of an output gear. It can also be expressed as the number of teeth on a gear as compared to the number of teeth on a gear that it is in mesh with.

Hydraulic Circuit: A fluid passage which often includes the mechanical components in that circuit designed to perform a specific function.

Input: A starting point for torque, revolutions or energy into another component of the transmission.

Internal Gear: The outermost member of a gear set that has gear teeth in constant mesh with planetary pinion gears of the gear set.

Internal Leak: Loss of fluid pressure in a hydraulic circuit.

Land (Valve Land): The larger diameters of a spool valve that contact the valve bore or bushing.

Line Pressure: The main fluid pressure in a hydraulic system created by the pump and pressure regulator valve.

Manual Valve: A spool valve that distributes fluid to various hydraulic circuits and is mechanically linked to the gear selector lever.

Orifice: A restricting device (usually a hole in the spacer plate) for controlling pressure build up into another circuit.

Overdrive: An operating condition in the gear set allowing output speed to be higher than input speed and output torque to be lower than input torque.

Overrunning: The function of a one-way mechanical clutch that allows the clutch to freewheel during certain operating conditions of the transmission.

Pinion Gear: A small toothed gear that meshes with a larger gear.

Planet Pinion Gears: Pinion gears (housed in a carrier) that are in constant mesh with a circumferential internal gear and centralized sun gear.

Planetary Gear Set: An assembly of gears that consists of an internal gear, planet pinion gears with a carrier, and a sun gear.

Powertrain Control Module (PCM): An electronic device that manages most of the electrical systems throughout the vehicle.

Pressure: A measurable force that is exerted on an area and expressed as kilopascals (kPa) or pounds per square inch (psi).

Pulse Width Modulated (PWM): An electronic signal that continuously cycles the ON and OFF time of a device (such as a solenoid) while varying the amount of ON time.

Race (Inner or Outer): A highly polished steel surface that contacts bearings or sprag or roller elements.

Reduction (Gear Reduction): An operating condition in the gear set allowing output speed to be lower than input speed and output torque to be higher than input torque.

Residual Fluid Pressure: Excess pressure contained within an area after the supply pressure has been terminated.

Roller Clutch: A mechanical clutch (holding device) consisting of roller bearings assembled between inner and outer races.

Servo: A spring loaded device consisting of a piston in a bore that is operated (stroked) by hydraulic pressure to apply or release a band.

Solenoid Valve: An electronic device used to control transmission shift patterns or regulate fluid pressure.

Spool Valve: A cylindrical hydraulic control device having a variety of land and valley diameters, used to control fluid flow.

Sprag Clutch: A mechanical clutch (holding device) consisting of figure eight like elements assembled between inner and outer races.

Throttle Position: The travel of the throttle plate that is expressed in percentages and measured by the throttle position (TP) sensor.

Torque: A measurable twisting force expressed in terms of Newton- meters (N•m), pounds feet (lbs ft) or pounds inches (lbs in).

Torque Converter: A component of an automatic transmission, (attached to the engine flywheel) that transfers torque from the engine to the transmission through a fluid coupling.

Variable Capacity Pump: The device that provides fluid for operating the hydraulic circuits in the transmission. The amount of fluid supplied varies depending on vehicle operating conditions.

ABBREVIATIONS

AC - Alternating Current	N - Neutral
A/C - Air Conditioning	NC - Normally Closed
ACC or ACCUM - Accumulator	Nm - Newton Meters
AFL - Actuator Feed Limit	NO - Normally Open
ALDL - Assembly Line Diagnostic Link	ORF - Orificed
AMP - Amperage	ORUN - Overrun
ASM - Assembly	OSS - Output Speed Sensor
AT - Automatic Transmission	
°C - Degrees Celsius	P - Park
CC - Converter Clutch	PCM - Powertrain Control Module
CL - Clutch	PC - Pressure Control (solenoid)
CONT - Control	PR - Park Reverse (circuit)
CONV - Converter	PRESS REG - Pressure Regulator
DC - Direct Current	PSI - Pounds per Square Inch
D.C. - Duty Cycle	PWM - Pulse Width Modulated
DLC - Diagnostic Link Connector	R - Reverse
DRAC - Digital Ratio Adaptor Converter	REV - Reverse
DTC - Diagnostic Trouble Code	RPM - Revolutions per Minute
D2 - Drive 2 (circuit)	SEL - Selective
D3 - Drive 3 (circuit)	SIG - Signal
D4 - Drive 4 (circuit)	SOL - Solenoid
D432 - Drive 432 (circuit)	SS - Shift Solenoid
ECM - Electronic Control Module	TCC - Torque Converter Clutch
ECT - Engine Coolant Temperature	TFP - Transmission Fluid Pressure
EX - Exhaust	TFT - Transmission Fluid Temperature
°F - Degrees Fahrenheit	TP - Throttle Position (sensor)
FD - Feed	TRANS - Transmission or Transaxle
FWD - Forward	
Hz - Hertz	V - Volts
ISS - Input Speed Sensor	VSS - Vehicle Speed Sensor
KM/H - Kilometers per Hour	2WD - 2 Wheel Drive
kPa - KiloPascals	4WD - 4 Wheel Drive
MAP - Manifold Absolute Pressure	
MPH - Miles per Hour	

INDEX

A	
Abbreviations	116
Accumulators	32-33
forward clutch accumulator	32
1-2 accumulator	32
3-4 accumulator	33
2-4 servo used as accumulator	33
Accumulator Valve	30
Actuator Feed Limit Valve	30
Apply Components	15-23
forward clutch	19
forward sprag clutch	21
low and reverse clutch	23
low and reverse roller clutch	22
overrun clutch	18
reverse input clutch	17
servo assembly and 2-4 band	16
3-4 clutch	20
B	
Ball Check Valves Location and Function	34-35
Band Assembly (2-4)	16
Basic Specifications	112
Boost Valve	29
Bushing and Bearing Locations	99
C	
Case and Associated Parts	102-104
Clutch (3-4)	20
Color Legend	10A-B
Complete Hydraulic Circuits	73-98
park	74-75
reverse	76-77
neutral	78-79
overdrive range – first gear	80-81
overdrive range – second gear	82-83
overdrive range – third gear	84-85
overdrive range – fourth gear (TCC applied)	86-87
overdrive range – 4-3 downshift	88-89
overdrive range – 3-2 downshift	90-91
manual third – third gear	92-93
manual second – second gear	94-95
manual first – first gear	96-97
lubrication points	98
Contents, Table of	2
Control Valve Body Assembly	106-107
Cross Sectional Views	8-8A
D	
Downshift Control Solenoid (3-2)	30, 41
E	
Electrical Components	36-44
component locations	36
fail safe mode	36
automatic transmission fluid pressure manual valve position switch	37
vehicle speed sensor	38
transmission fluid temperature sensor	38
torque converter clutch solenoid valve	39
shift solenoid valves	40
3-2 downshift control solenoid valve	41
pressure control solenoid valve	42
TCC PWM solenoid valve	43
components external to the transmission	44
Explanation of Gear Ranges	9
F	
Fail Safe Mode	36
First Gear (overdrive)	54-55, 80-81
Forward Clutch	19
Forward Sprag Clutch	21
G	
General Description	9
Glossary Of Technical Terms	114-115
H	
How To Use This Book	4-5
Hydra-matic Product Designation System	113
Hydraulic Control Components	26-35
location of major components	26
oil pump assembly	27
pressure regulation	28
valves located in the oil pump assembly	29
valves located in the control valve body	30-31
accumulators	32-33
ball check valves location and function	34-35
I	
Illustrated Parts List	101-111
case and associated parts	102-104
oil pump assembly	105
control valve body assembly	106-107
internal components	108-110
parking pawl and actuator assembly	111
Introduction	3
L	
Low and Reverse Clutch	23
Low and Reverse Roller Clutch	22
Lubrication Points	98
M	
Major Mechanical Components	10
Manual First – First Gear	70-71, 96-97
Manual Second – Second Gear	68-69, 94-95
Manual Third – Third Gear	66-67, 92-93
Manual Valve	30
N	
Neutral	52-53, 78-79

INDEX

O

Oil Pump Assembly	27, 105
Operating Conditions - Range Reference Chart	72
Overdrive Range – First Gear	54-55, 80-81
Overdrive Range – Fourth Gear (TCC Released)	60-61
Overdrive Range – Fourth Gear (TCC Applied)	62-63, 86-87
Overdrive Range – Second Gear	56-57, 82-83
Overdrive Range – Third Gear	58-59, 84-85
Overdrive Range – 4-3 Downshift	64, 88-89
Overdrive Range – 3-2 Downshift	65, 90-91
Overrun Clutch	18

P

Park	48-49, 74-75
Parking Pawl and Actuator Assembly	111
Planetary Gear Sets	24-25
description	24A
reduction	24A
direct drive	24B
overdrive	24B
reverse direction of rotation	24B
Power Flow	45-72
mechanical powerflow from TCC	46-46A
common hydraulic functions	46B-47
park	48-49
reverse	50-51
neutral	52-53
overdrive range – first gear	54-55
overdrive range – second gear	56-57
overdrive range – third gear	58-59
overdrive range – fourth gear	60-61
overdrive fourth, TCC released to applied	62-62A
overdrive fourth, TCC applied to released	62B-63
overdrive range – 4-3 downshift	64-64A
overdrive range – 3-2 downshift	64B-65
manual third – third gear	66-67
manual second – second gear	68-69
manual first – first gear	70-71
Preface	1
Pressure Control Solenoid Valve	30, 42
Pressure Regulation	28
Pressure Regulator Valve	29
Principles of Operation	9A-44
major mechanical components	10
color legend	10A-B
range reference chart	11
torque converter	12-14
apply components	15-23
planetary gear sets	24-25
hydraulic control components	26-35
electrical components	36-44

R

Range Reference Charts	11, 72
Reverse	50-51, 76-77
Reverse Input Clutch	17

S

Seal Locations	100
Servo Assembly	16
Shift Solenoid Valves	40
Stator Assembly	13

T

Table of Contents	2
Torque Converter Clutch Solenoid	39
TCC PWM Solenoid Valve	30, 43
Regulated Apply Valve	30
Torque Converter Clutch Apply Valve	29
TFP Manual Valve Position Switch	37
Third Gear (overdrive)	58-59, 84-85
Torque Converter Clutch	12-14
converter pump and turbine	12
pressure plate	12
stator assembly	13
torque converter apply and release	14
Torque Converter Clutch Applied	62B-63, 86-87
Torque Converter Clutch Released	62-62A
TFT sensor	38
Transmission Adapt Function	42

U

Understanding The Graphics	6-8A
----------------------------------	------

V

Valves Located In The Control Valve Body	30-31
3-4 shift valve	30
3-2 downshift valve	30
reverse abuse valve	30
3-2 control solenoid valve	30
3-2 control valve	30
manual valve	30
pressure control solenoid valve	30
actuator feed limit valve	30
TCC PWM solenoid valve	30
regulated apply valve and isolator valve	30
3-4 relay valve and 4-3 sequence valve	30
accumulator valve	30
2-3 shift solenoid valve	30
2-3 shift valve and 2-3 shuttle valve	30
1-2 shift solenoid valve	31
1-2 shift valve	31
forward abuse valve	31
low overrun valve	31
forward clutch accumulator	31
Valves Located In The Oil Pump Assembly	29
pressure regulator valve	29
boost valve	29
torque converter clutch apply valve	29
pressure relief ball	29
torque converter clutch solenoid	29
retainer and checkball assemblies	29
orifice cup plugs	29
Vehicle Speed Sensor	38

