

Fig. 2: Engine Compartment (5.0L VIN M & 5.7L VIN R)
1998 Chevrolet Suburban K1500

COMPUTER HARNESS

- C1. Vehicle Control Module (VCM)
- C2. Data Link Connector (DLC)
- C6. Dash Fuse Block
- C6a. Underhood Fuse/Relay Center
- C8. Fuel Pump Prime Connector

CONTROLLED DEVICES

- 1. Fuel Injectors
- 2. Idle Air Control (IAC) Valve
- 4. Exhaust Gas Recirculation (EGR) Valve Solenoid
- 9. Evaporative Emissions (EVAP) Canister Purge Solenoid
- 10. Ignition Control Module
- 15. Fuel Pump Relay

INFORMATION SENSORS

- A. Manifold Absolute Pressure (MAP) Sensor
- C. Throttle Position (TP) Sensor
- D. Engine Coolant Temperature (ECT) Sensor
- E. Mass Air Flow (MAF) Sensor
- F. Vehicle Speed Sensor (VSS)
- G. Camshaft Position (CMP) Sensor
- H. Transmission Input Speed Sensor (4L80E automatic transmission)
- J. Knock Sensor (KS)
- K. Evaporative Emission (EVAP) Purge Solenoid Vacuum Switch

- L. Intake Air Temperature (IAT) Sensor
- M. Crankshaft Position (CKP) Sensor
- P. Distributor
- H. Ignition Coil
- S. Fuel Pump/Oil Pressure Switch
- T. A/C Compressor Clutch Cycling Switch
- U. A/C High Pressure Cutout Switch

ANTI-LOCK BRAKE COMPONENTS

- A1. Brake Pressure Modulator Valve (BPMV)
- A2. Front Wheel Speed Sensor

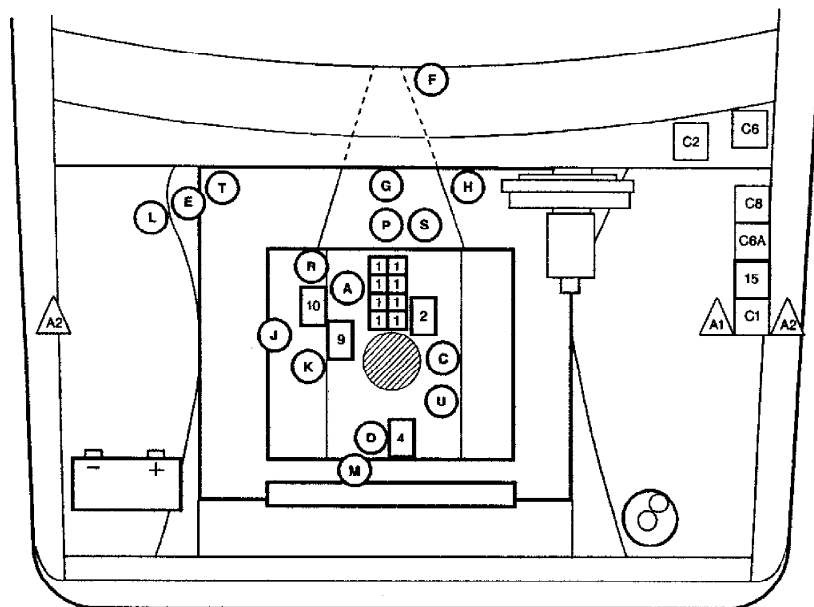

5.0L (VIN M) & 5.7L (VIN R)

- 1. HO2S Bank 1 Sensor 3
- 2. HO2S Bank 1 Sensor 1
- 3. HO2S Bank 2 Sensor 1

